

1. BACK BOXES RANGE (cont.)

1.1 Auto adjustable back box reference numbers 0 880 90/91/92

1.1.1 Dimensions

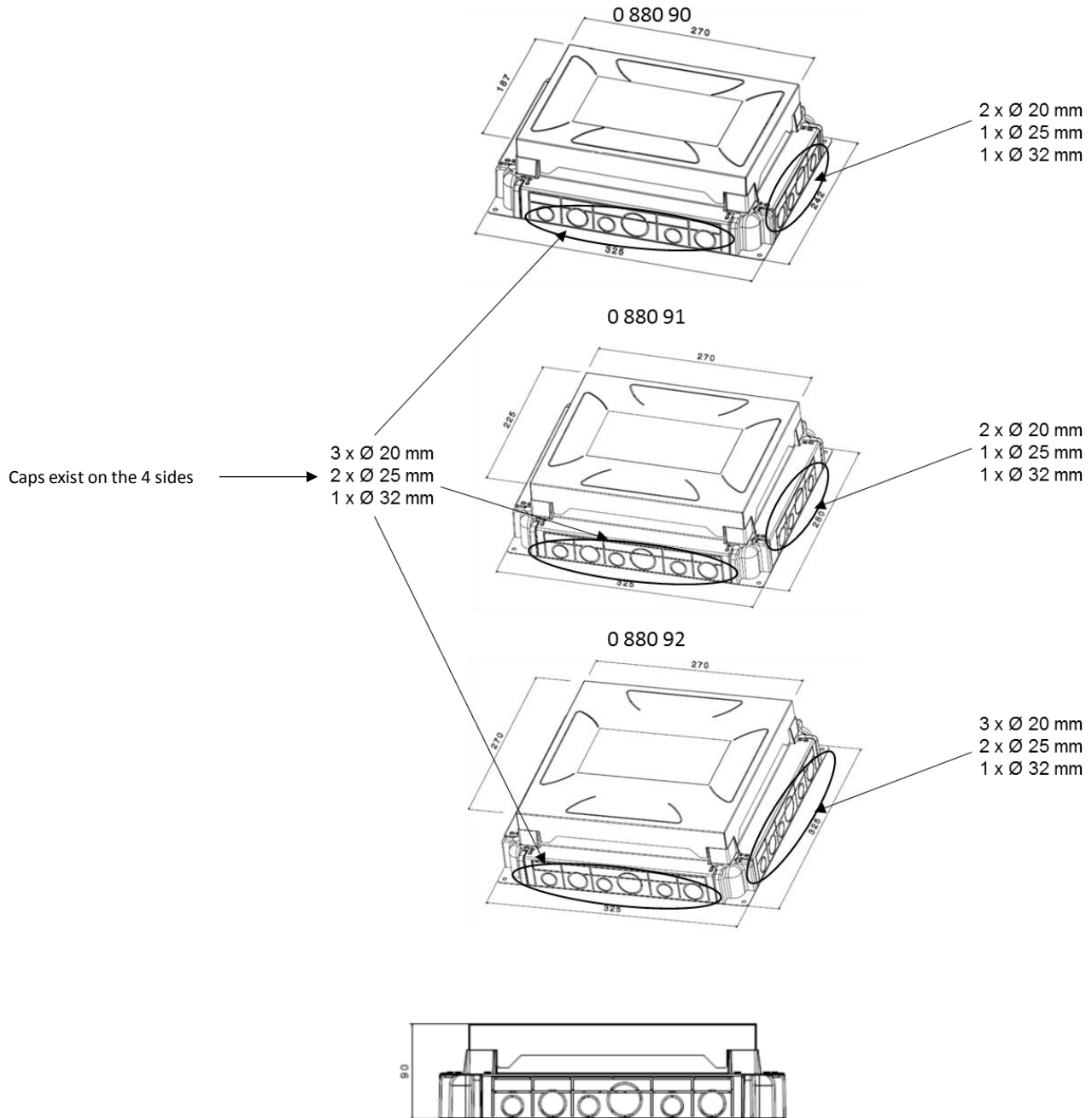

1. BACK BOXES RANGE (cont.)

1.1.2. Pouring concrete

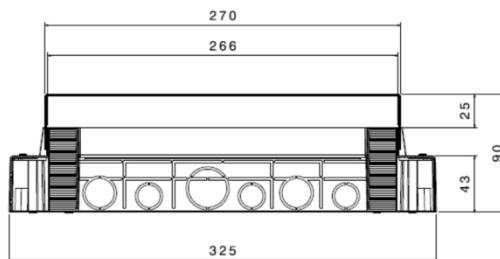

Fix the back box on the slab

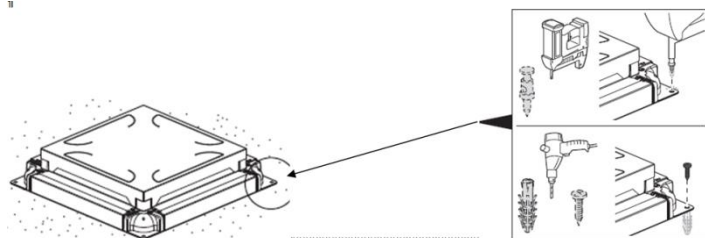

Put the trunking or flexible conduits (use a tool to fold), the side plates (figure 1) have to be cut out to fit the required ducting and/or conduits

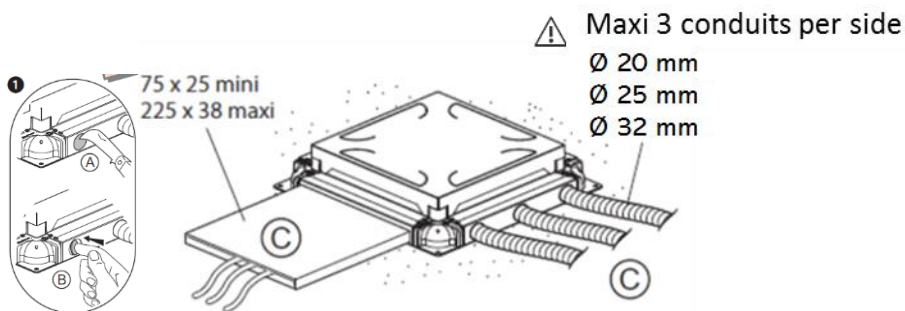

Pour the concrete

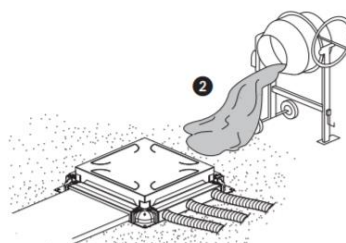

Push to fold and pull up the metal protection to install the floor boxes

