

SACE Tmax XT

Istruzioni di installazione XT1
 Installation instructions XT1
 Installationsanleitung XT1
 Instructions pour l'installation XT1
 Instrucciones de instalación XT1
 安装说明书 XT1

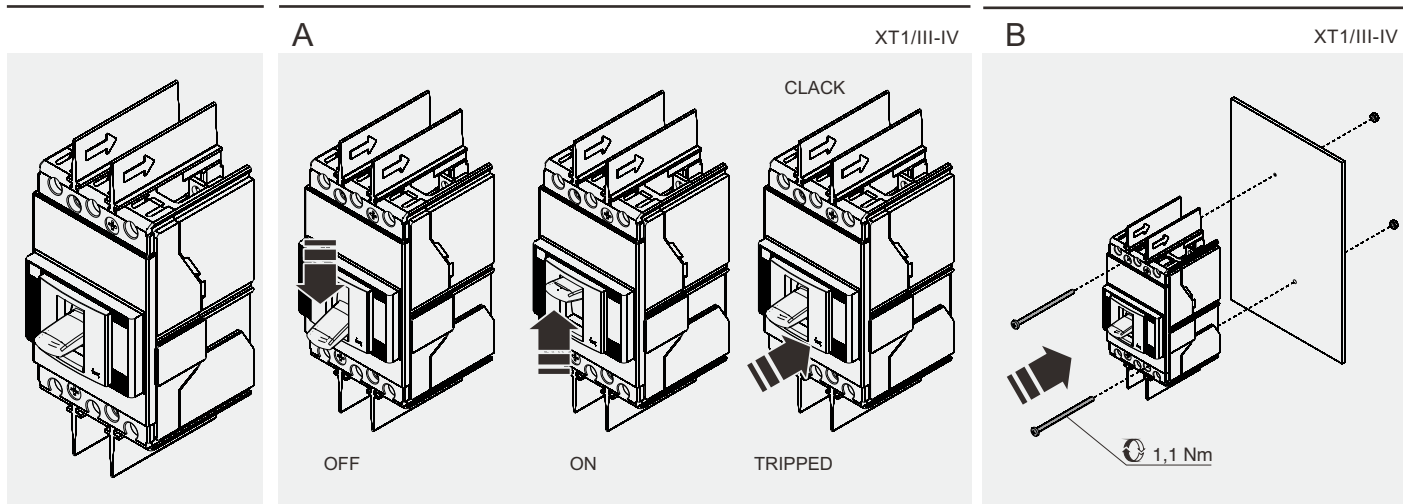

C XT1/III-IV

Usare cavi o barre isolate/ o eseguire prove di tipo specifiche sull' installazione.
 Use cable or insulated busbars/ or performspecific type test on the installation.
 Kabel oder isolierte Sammelschienen verwenden / oder die spezifische Typprüfung bei der Installation durchführen.
 Utiliser un câble ou des barres isolées/ ou réaliserun test de type spécifique sur installation.
 Utilizar un cable o barras aisladas / o efectuaruna prueba de tipo específico sobre instalación.
 使用电缆或经绝缘处理的母排， 否则需对安装进行指定的型式试验

L'utilizzo di barre non isolate con $U_e \leq 480V$ prevede il montaggio obbligatorio di coprimermini HTC.
 The use of not insulated busbars with $U_e \leq 480V$ involves the mandatory assembly of terminal-covers HTC.
 Die Benutzung von nicht isolierten Sammelschienen mit $U_e \leq 480V$ sieht die obligatorisch Montage von der Klemmenabdeckung HTC vor.
 L'utilisation de barres non isolées avec $U_e \leq 480V$ prévoit le montage obligatoire du cache-bornes HTC.
 La utilización de barras no aisladas con $U_e \leq 480V$ prevé el montaje obligatorio de cubre-bornes HTC.
 使用不绝缘母线必须安装高端子盖板HTC。

D

XT1/III-IV

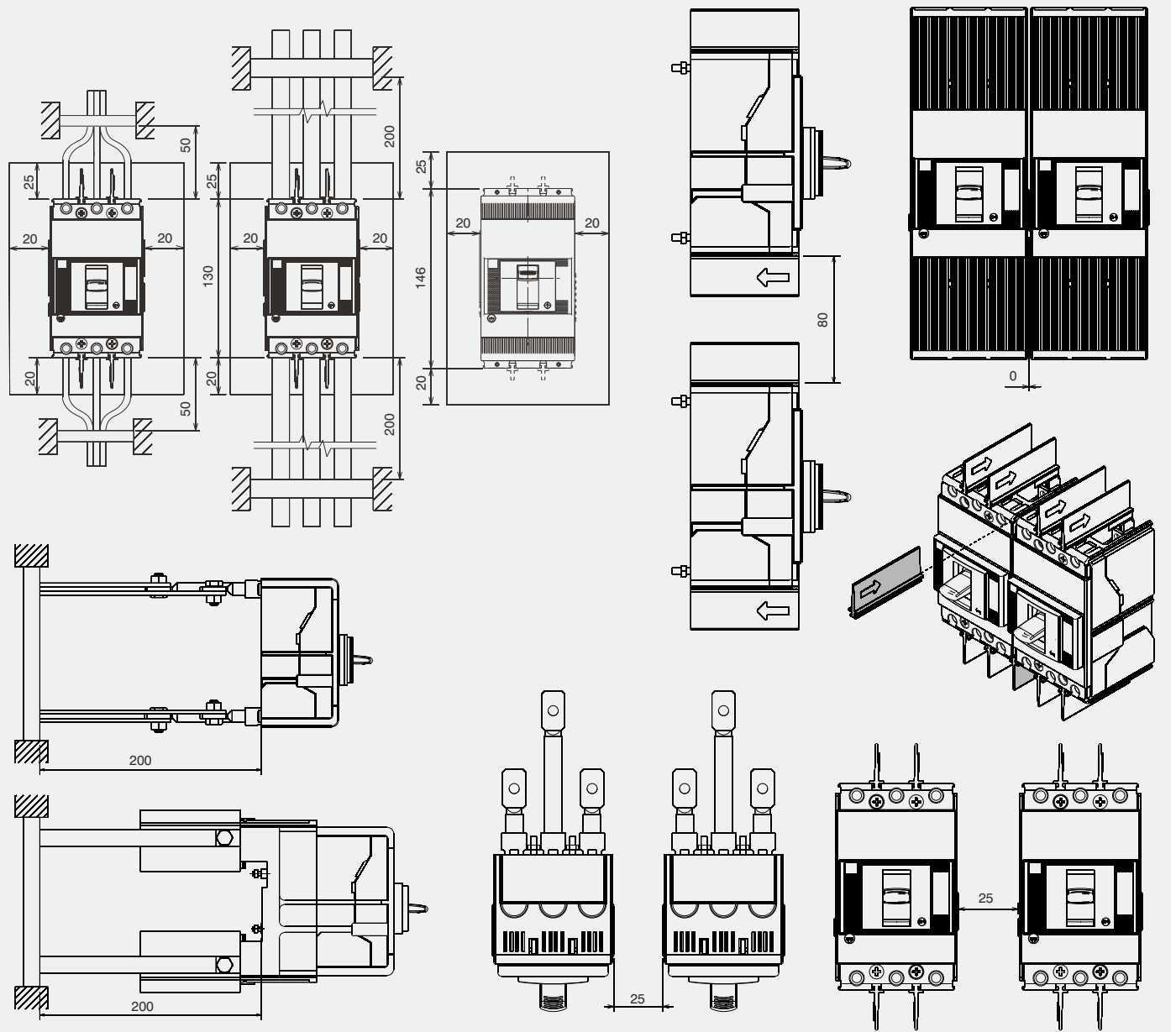

E

XT1-F/III-IV/F

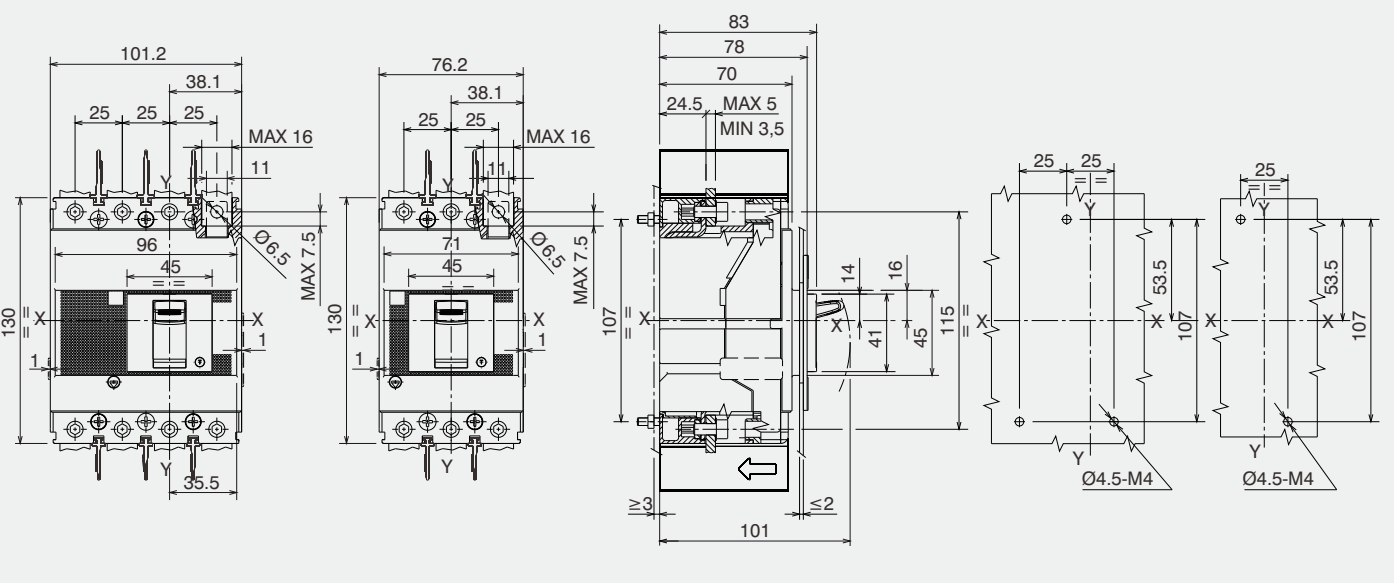

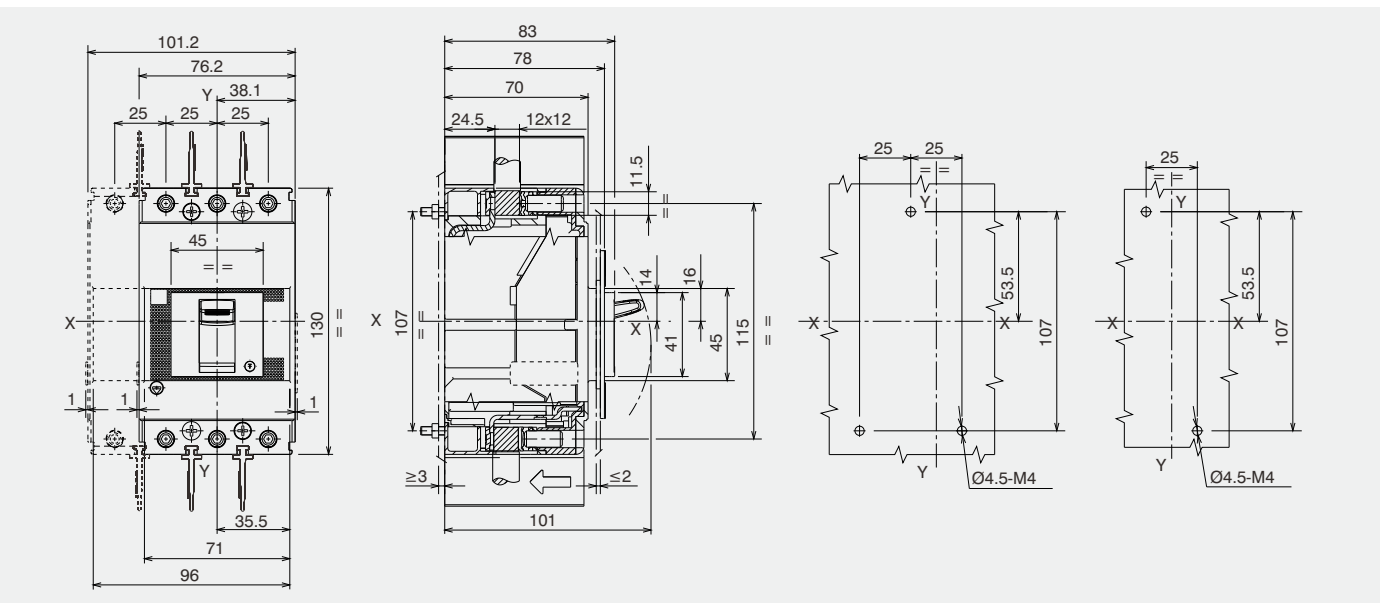
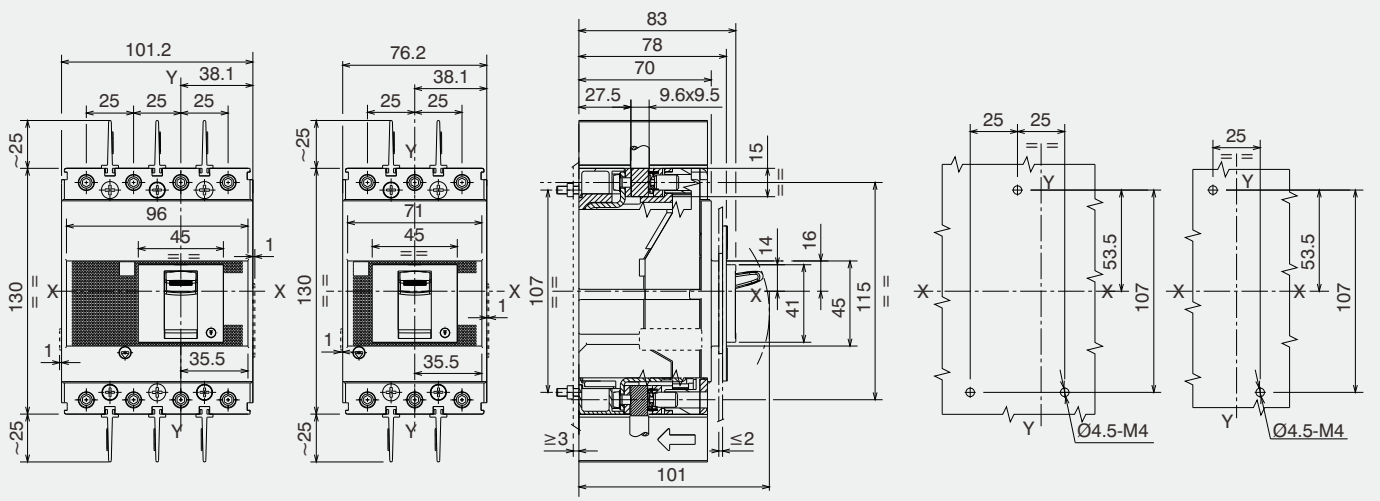
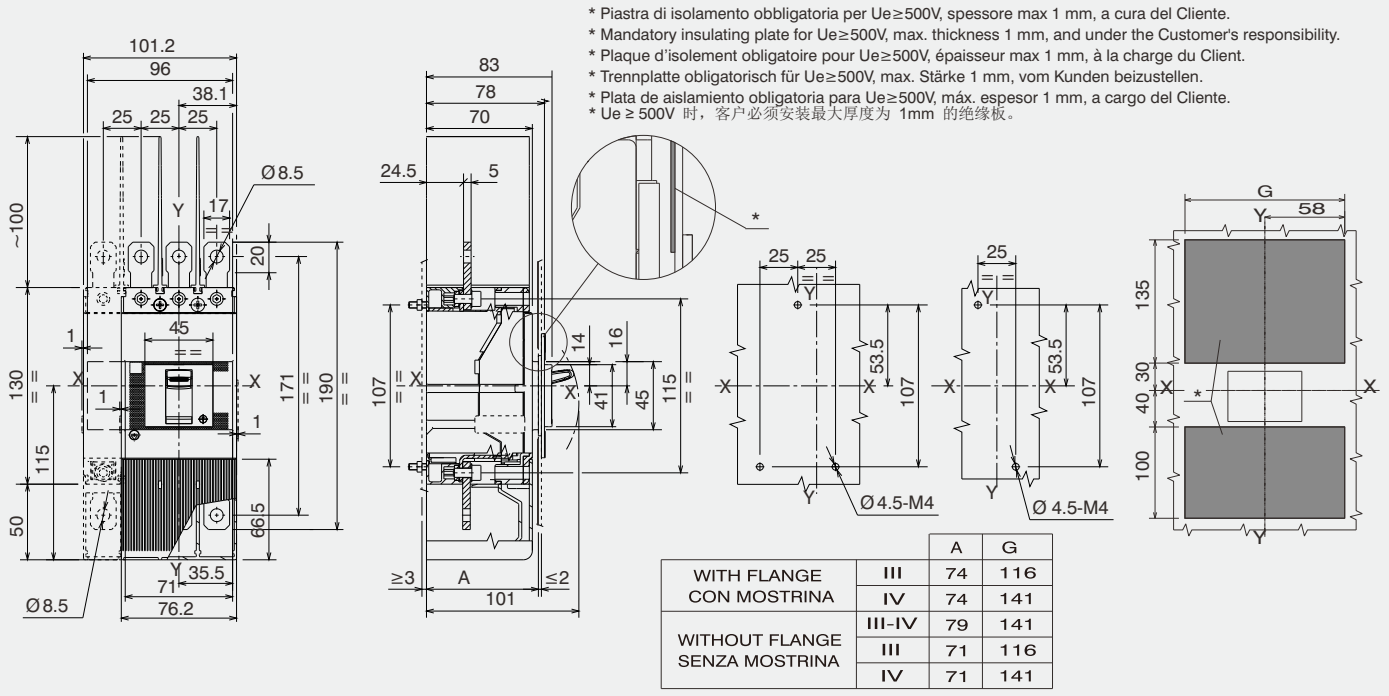

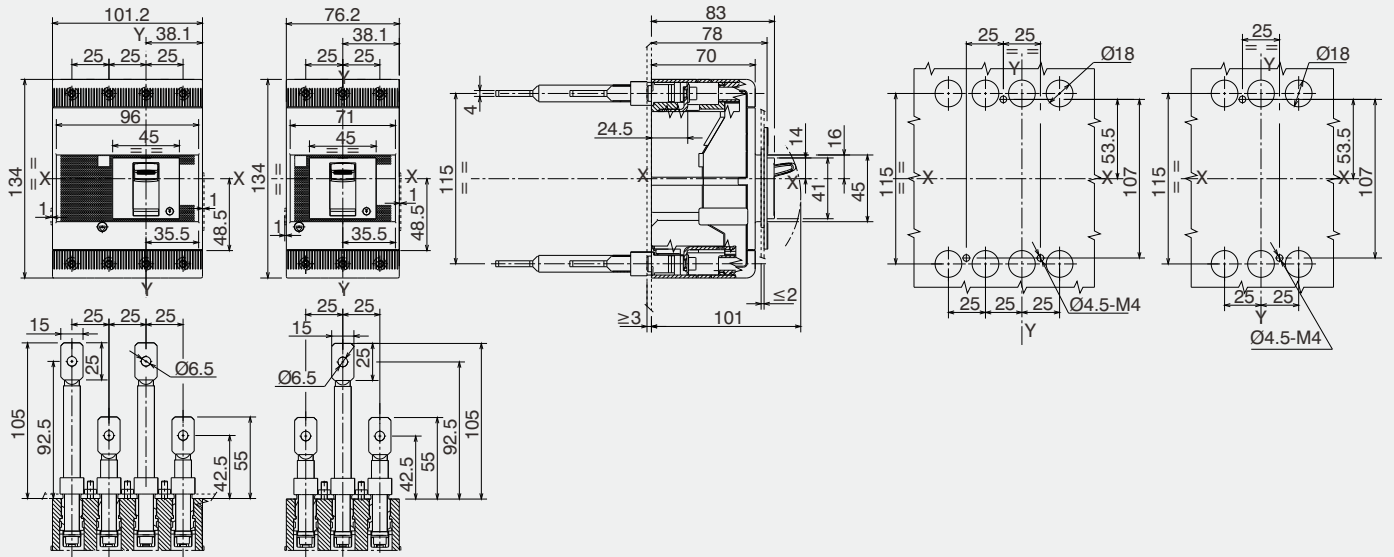

J

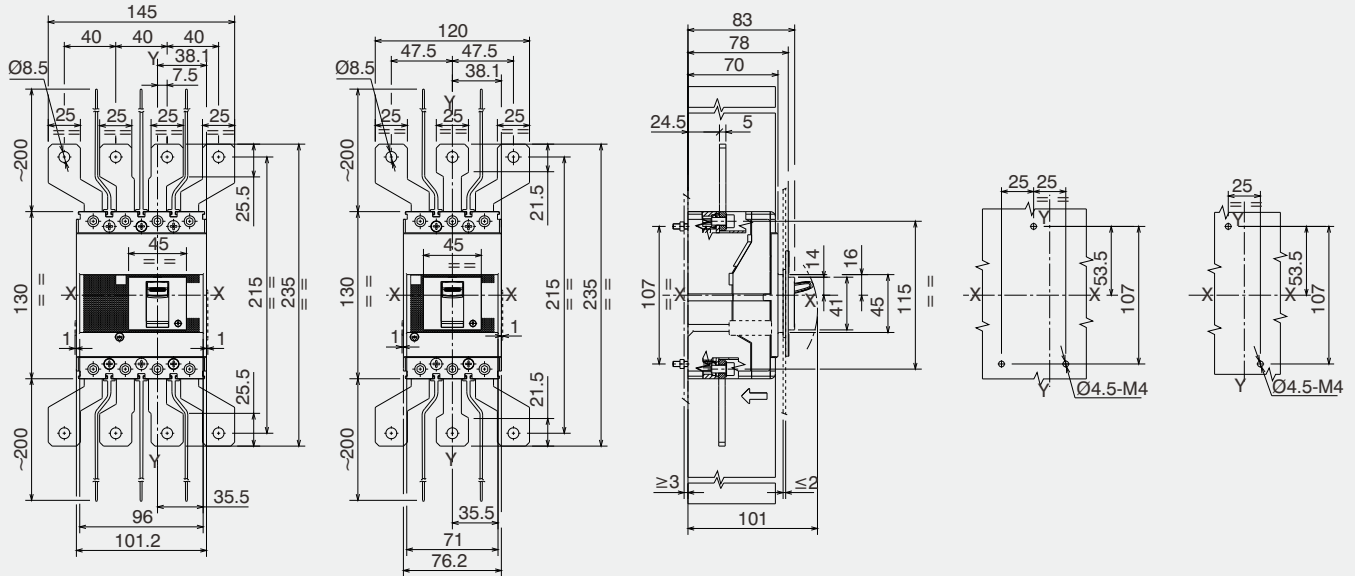

K

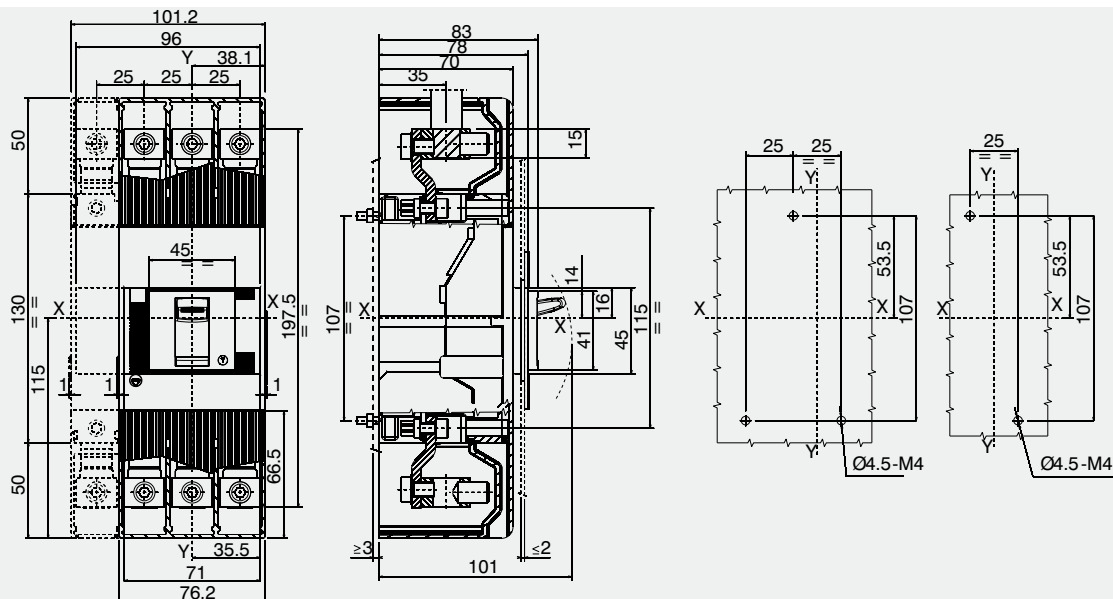

L

XT1-F/III-IV/Mc

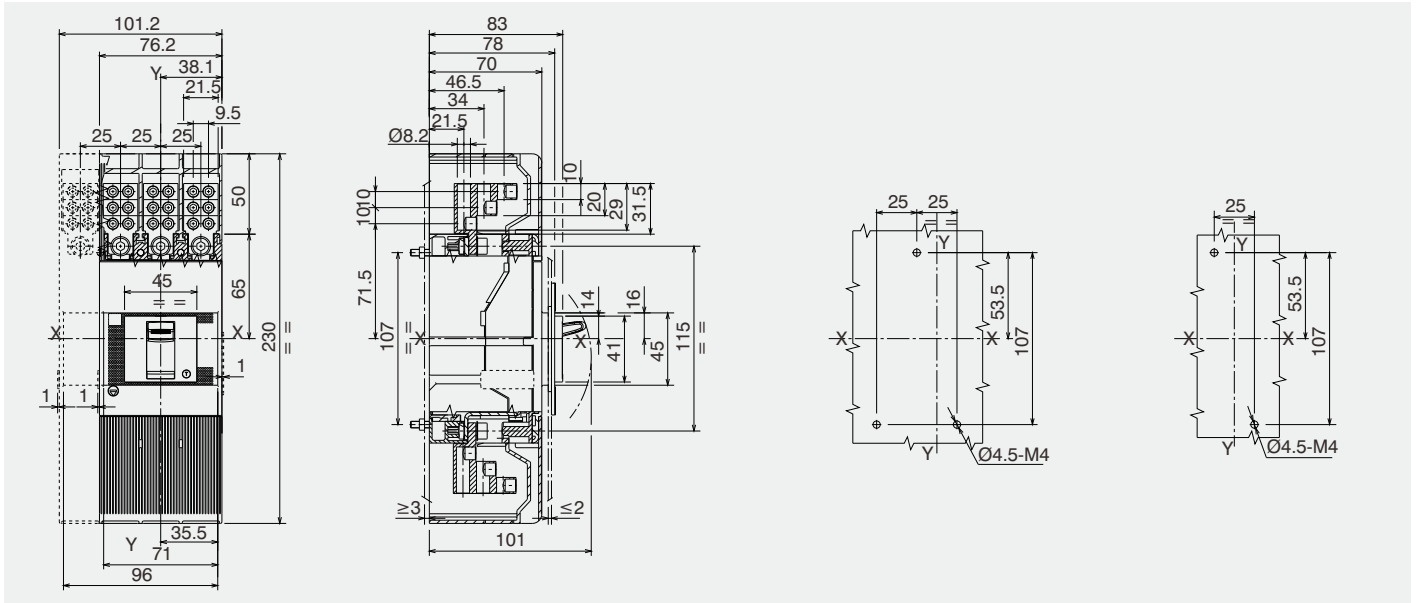

M

XT1-P/III-IV/EF

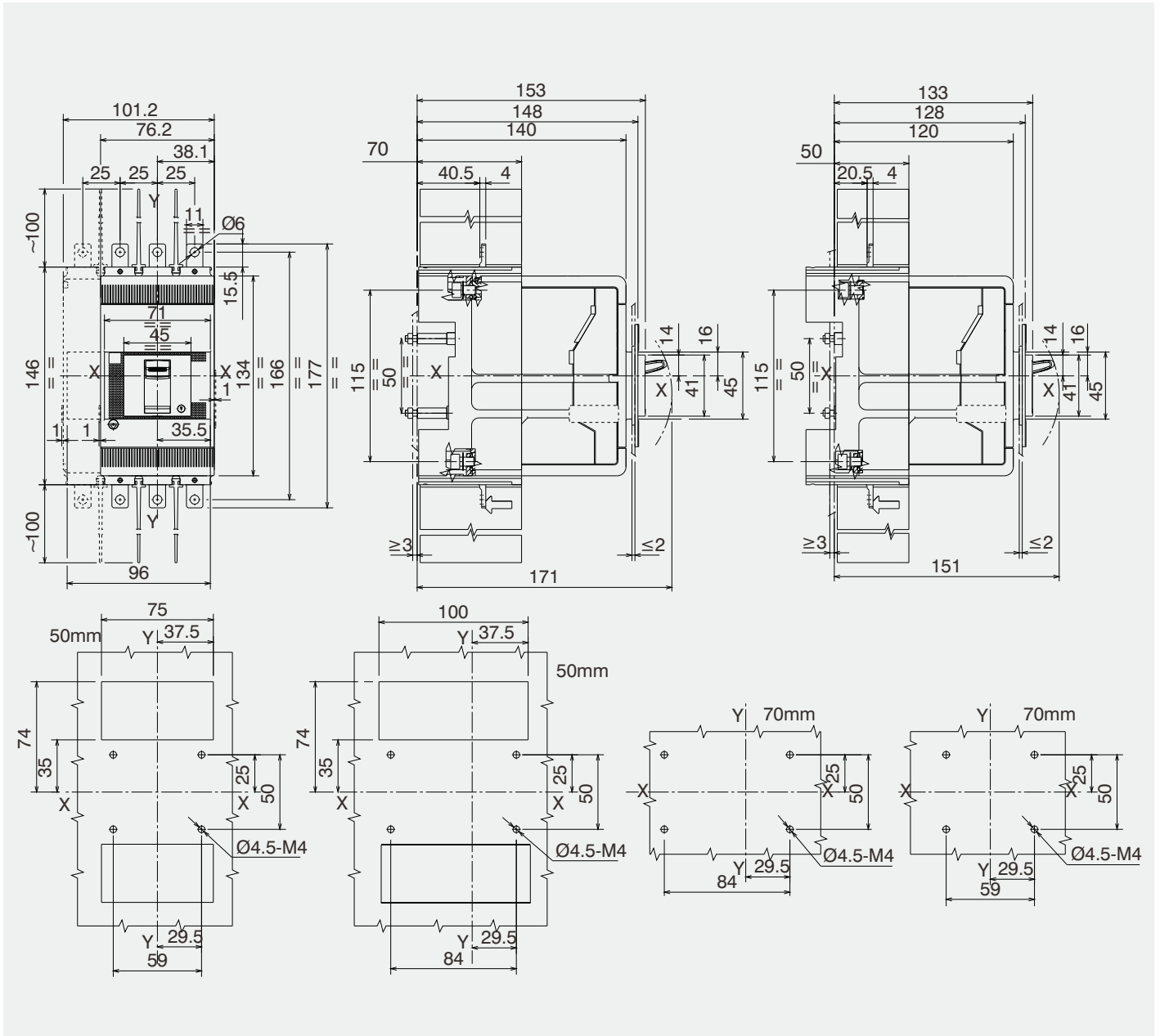

P

XT1-P/III-IV/Fc Cu/MC

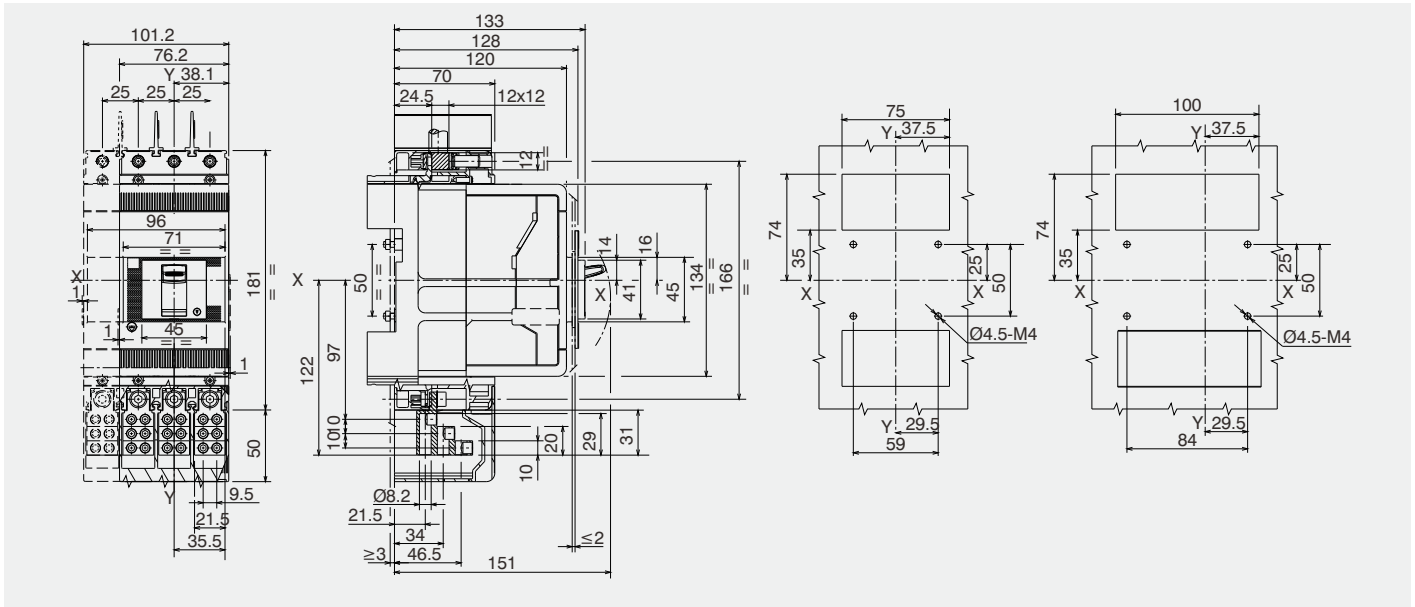

Q

XT1-P/III-IV/Fc-CuAl

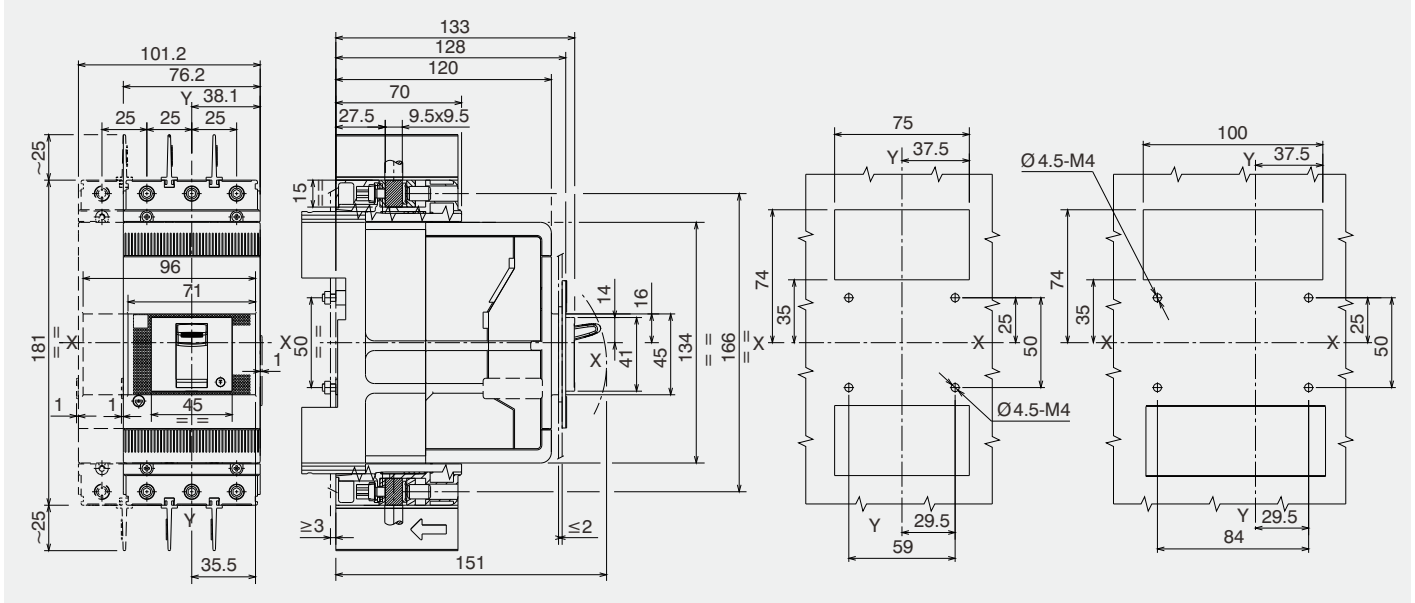

R

XT1-P/III-IV/Fc-CuAl EXT

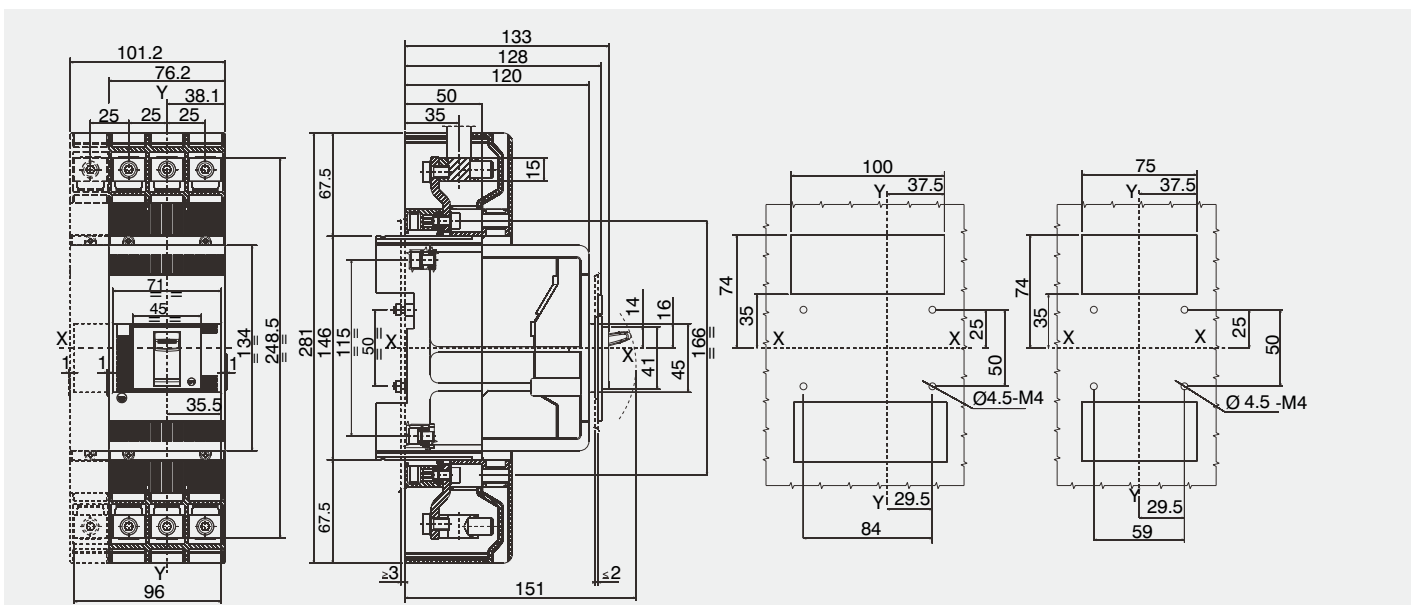

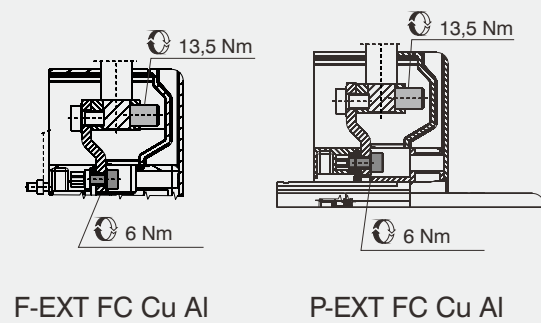
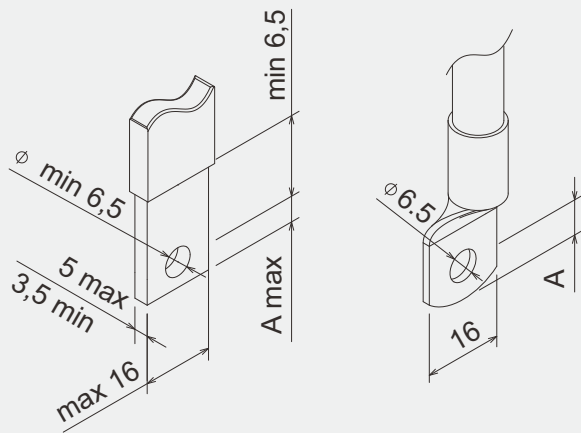
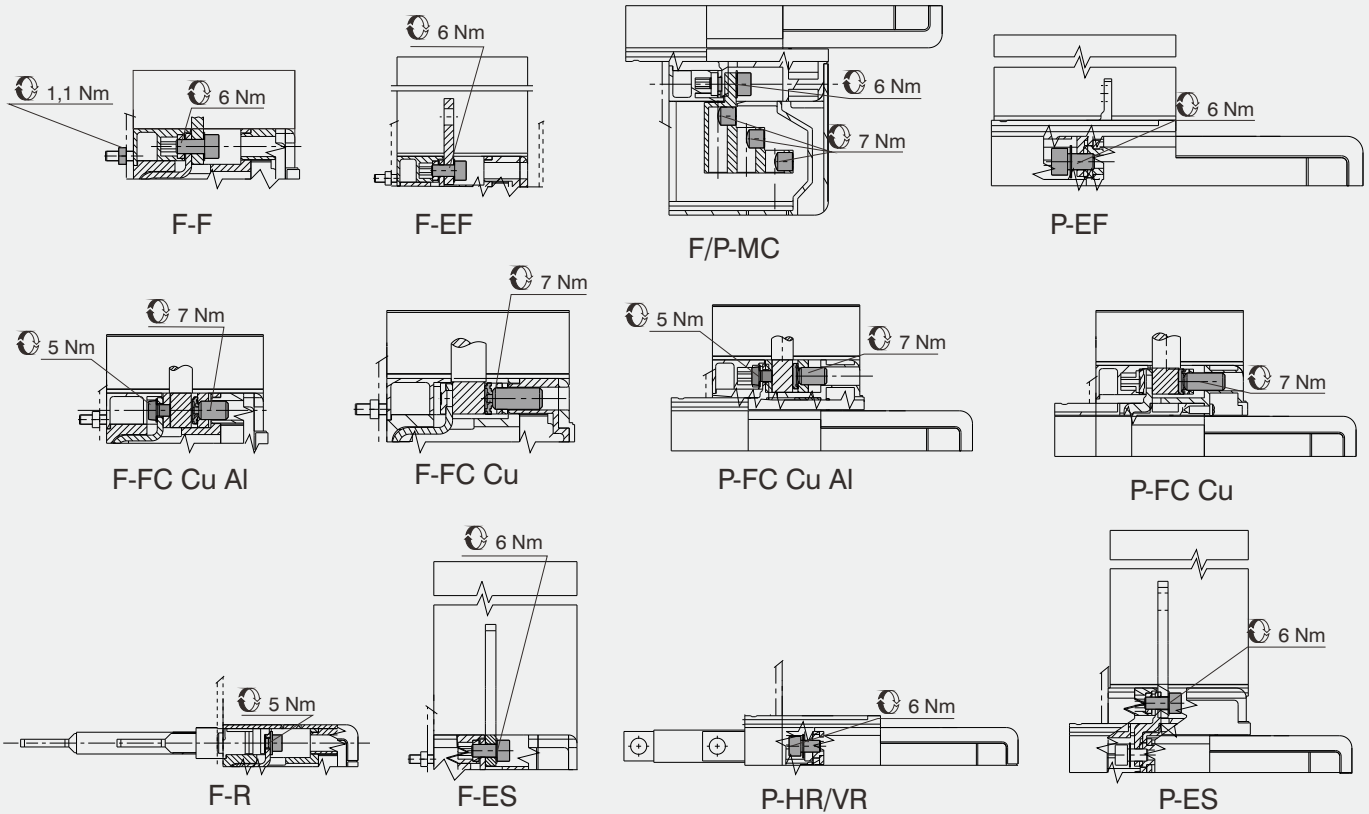

	A
MCCB	7,5
MCP	6

		FC Cu		FC CuAl		Mc		FC CuAl Ext	
		MAX	MIN	MAX	MIN	MAX	MIN	MAX	MIN
Stranded		70 mm ²	2,5 mm ²	50 mm ²	1,5 mm ²	35 mm ²	2,5 mm ²	95 mm ²	35 mm ²
Flexible		50 mm ²	2,5 mm ²	50 mm ²	1,5 mm ²	25 mm ²	2,5 mm ²		

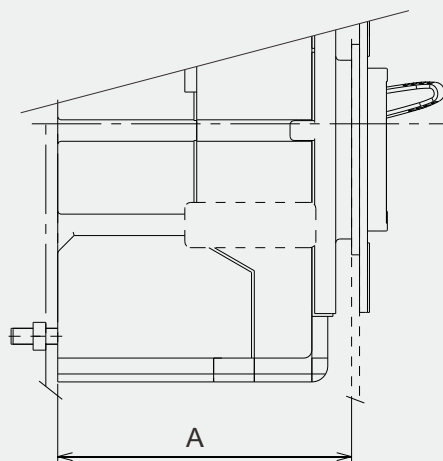
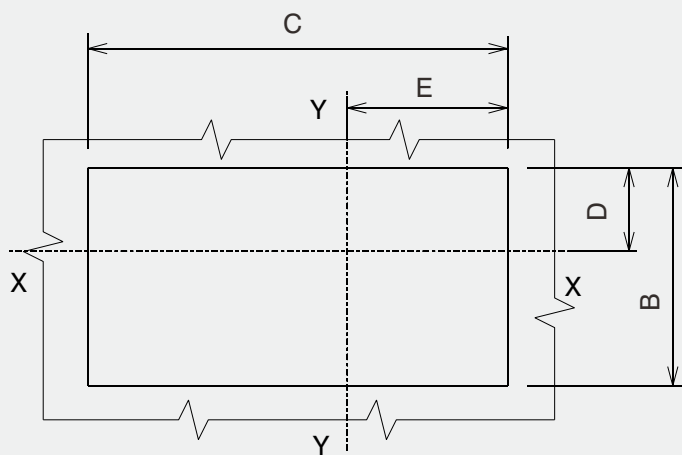
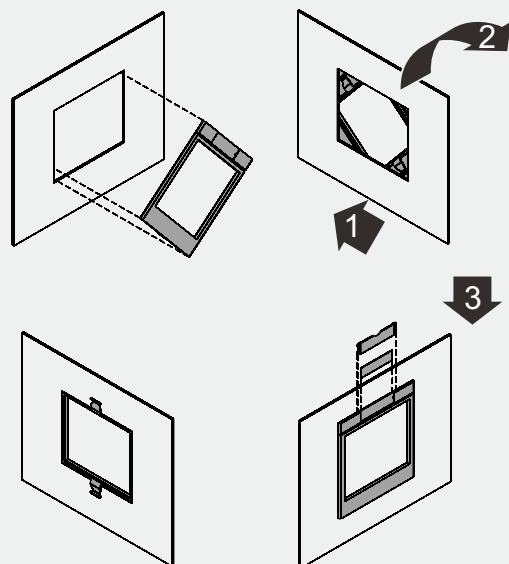

XT1 WITH FLANGE CON MOSTRINA		A		B	C	D	E	
		F	P					
		50mm	70mm					
	III	74	124	144	55	81	21	40,5
	IV	74	124	144	55	106	21	40,5
	OPTIONAL FLANGE III-IV	79	129	149	73	57	30	28,5

XT1 WITHOUT FLANGE SENZA MOSTRINA		A		B	C	D	E	
		F	P					
		50mm	70mm					
	III-IV	79	129	149	43	47	15	23,5
	III	71	121	141	47	73	17	36,5
	IV	71	121	141	47	98	17	36,5

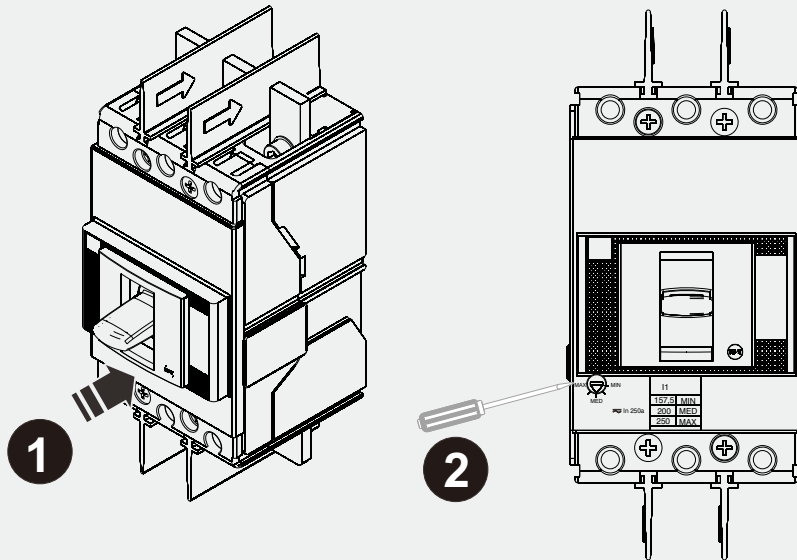

		I1		
		In	MIN (0,7xIn)	MED (0,85xIn)
TMD	16	11,2	13,6	16,0
	20	14	17	20
	25	17,5	21,3	25
	32	22,4	27,2	32
	40	28	34	40
	50	35	42,5	50
	63	44,1	53,6	63
	80	56	68	80
	100	70	85	100
	125	87,5	106,3	125
	160	112	136	160

		In	I1	I3
TMF	Fixed	16	16	450
	Fixed	20	20	450

E'obbligatorio mettere l'interruttore in posizione Trip test prima di regolare il termomagnetico.

It is mandatory to turn the circuit breaker to Trip test mode before adjusting the thermomagnetic release.

Der Leistungsschalter muss vor Einstellung des thermomagnetischen Auslösers zwingend in die Prüfstellung geschaltet werden.

Il est obligatoire de mettre le disjoncteur en position de Test de Déclenchement avant de régler le déclencheur magnétothermique.

Es obligatorio situar el interruptor en posición "Test de Disparo" antes de realizar el ajuste del relé termomagnético.

调整热磁脱扣器前必须使开关处于跳扣状态