

	MicroRex T11 4127 80	MicroRex W11 4127 83	MicroRex T11 4127 81	MicroRex QT11 4127 90	MicroRex QW11 4127 94	MicroRex QT11 4127 91	MicroRex QW11 4127 96	
	• 230 V~ 50 Hz • 230 B~ 50 Гц • 230 واط ~ 50 ميغاهرتز		• 120 V~ 60 Hz • 120 B~ 60 Гц • 120 فولت ~ 60 ميغاهرتز		• 230 V~ 50-60 Hz • 230 B~ 50-60 Гц • 230 واط ~ 50-60 ميغاهرتز		• 120 V~ 50-60 Hz • 120 B~ 50-60 Гц • 120 واط ~ 50-60 ميغاهرتز	
	• R 100 h / +25 °C • R 100 ч / +25 °C • احتياطي تشغيل 100 ساعة / 25+ مئوية							
	• 0,6 W • 0,6 Bт • 0,6 واط							
	• ± 2 s/d +25 °C • ± 2 c/сут. +25 °C • ± ثانية باليوم +25 مئوية							
	• 16 A/250 V~μ cos φ = 1 • 16 A/250 B~μ cos φ = 1 • 16 أمبير/فولت~μ cos φ = 1							
	 • 1,5...4 mm ² • 1,5 ... 4 MM ² • 2مم 4...1.5		 • 1,5...2,5 mm ² • 1,5 ... 2,5 MM ² • 2مم 2.5...1.5			 8 mm • 8 مم		
	• - 10 °C ... +55 °C • 10° - مئوية...+55 مئوية							
	• - 10 °C ... +60 °C • 10° - مئوية...+60 مئوية							
IP	30							

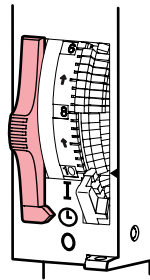

• Automatic • Авт. реж.
• Αυτόματο • أوتوماتيك

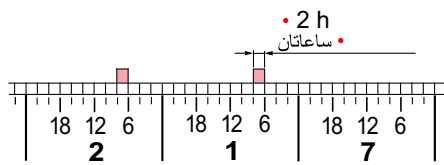
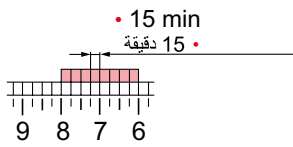
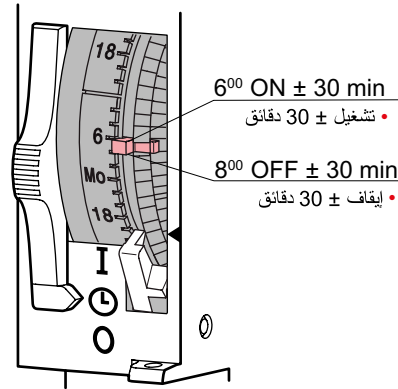
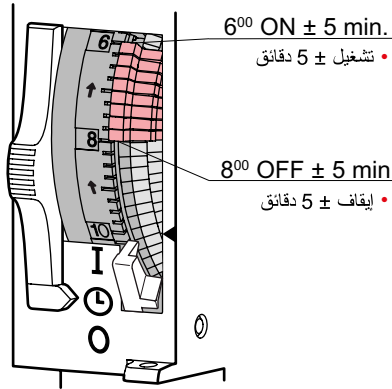
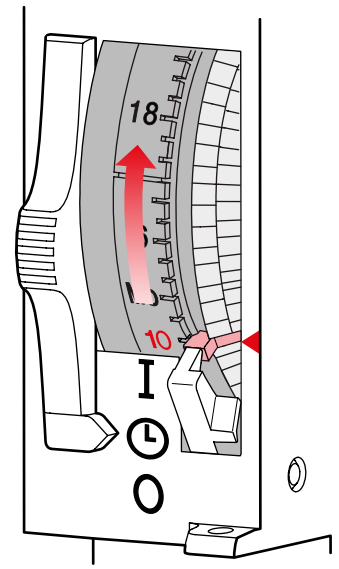
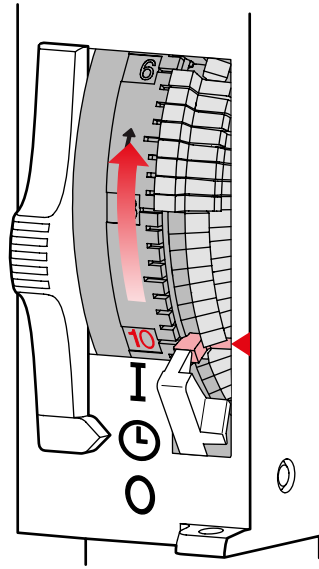
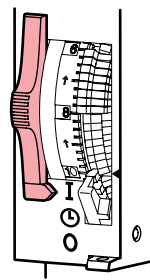

• ON

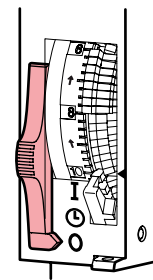

• OFF