

STRIP FORM Bandware

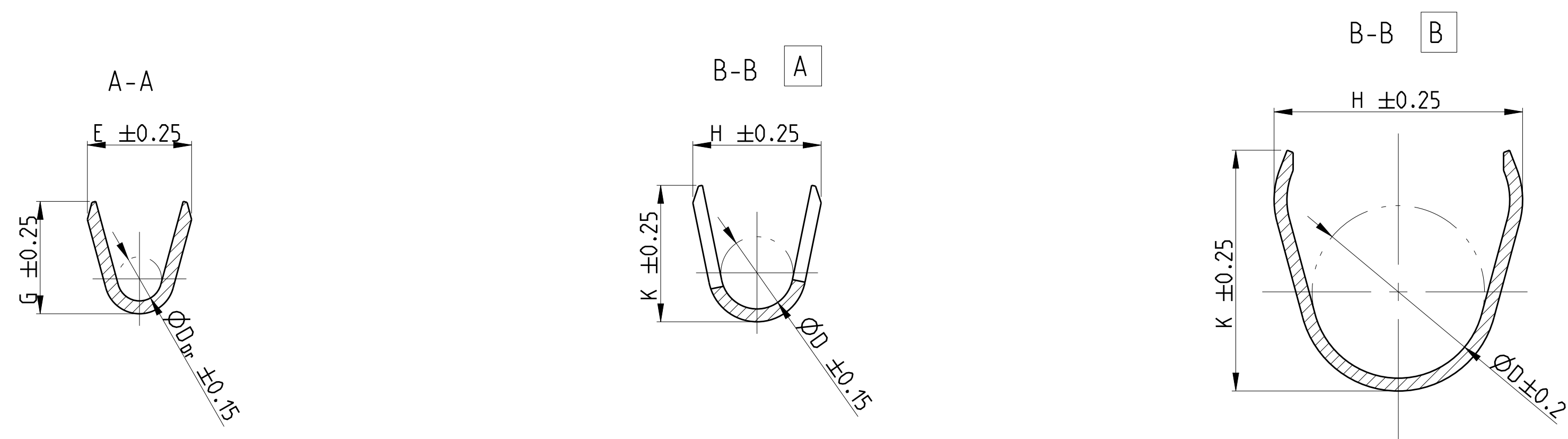

- 1 CONTACT AREA PRE SILVER MIN. 3µm
CANTILEVER SPRING PLAIN
Kontaktzone vorversilbert min. 3µm
Ueberfeder blank
- 2 CONTACT BODY NI-PLATING MIN. 0.5µm; CONTACT AREA PRE-GOLD MIN. 0.6µm
OVER NICKEL; CRIMP AREA PRE-TIN
CANTILEVER SPRING PLAIN
Kontaktkoerper vernickelt min. 0.5µm; Kontaktzone vorvergoldet min. 0.6µm ueber Nickel
Crimpzone vorverzinkt; Ueberfeder blank
- 3 IN THIS AREA CRACK SHAPING AT THE SURFACE PERMISSIBLE
In diesem Bereich Rissbildung in der Oberflaeche zulassig
- 4 PRE-TIN MIN. 1µm; CANTILEVER SPRING PLAIN
vorverzinkt min. 1µm; Ueberfeder blank
- 5 AWG 12 TXL 828905-1 OR / oder 282536-1
AWG 12 GXL 638865-1
- 6 ATTENTION! CONSTRUCTION OF THE CONTACT CAVITY IN THE AREA OF THE SINGLE WIRE SEAL IS Ø6.4^{+0.1}_{-0.05}
Achtung! Die Kammer ist im Bereich der Einzeldichtung auf Ø6.4^{+0.1}_{-0.05} auszuliegen
- 7 PUNCHED WITH VOLATILIZING STAMPING-OIL
Gestanz mit verfluechtigendem Stanzoel

FLR-/FLK-WIRE FLR-/FLK-Leitung

DESIGN 1 Ausfuehrung 1

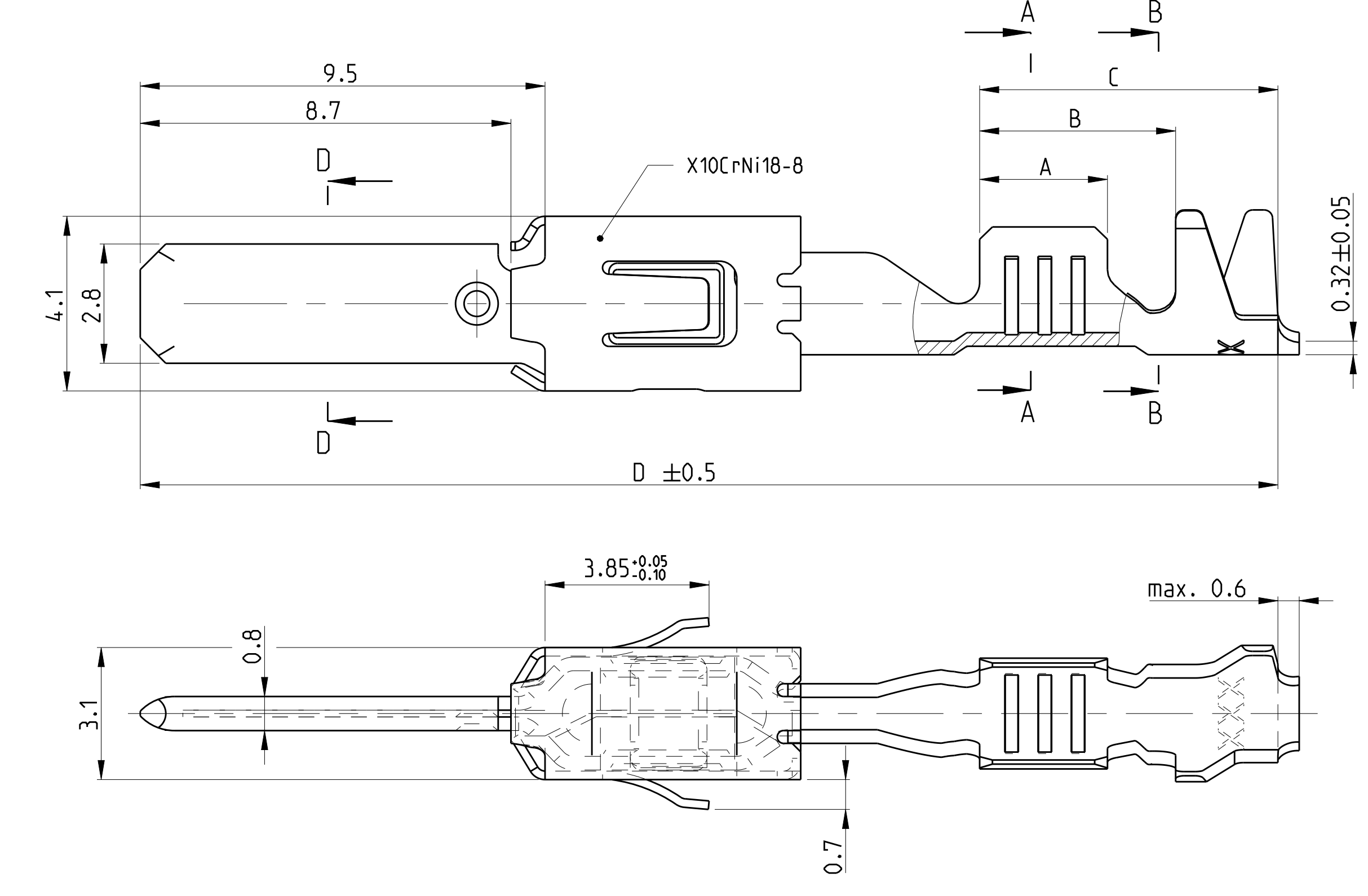

SINGLE WIRE SEAL Einzeldichtungssystem

DESIGN 4 Ausfuehrung 4

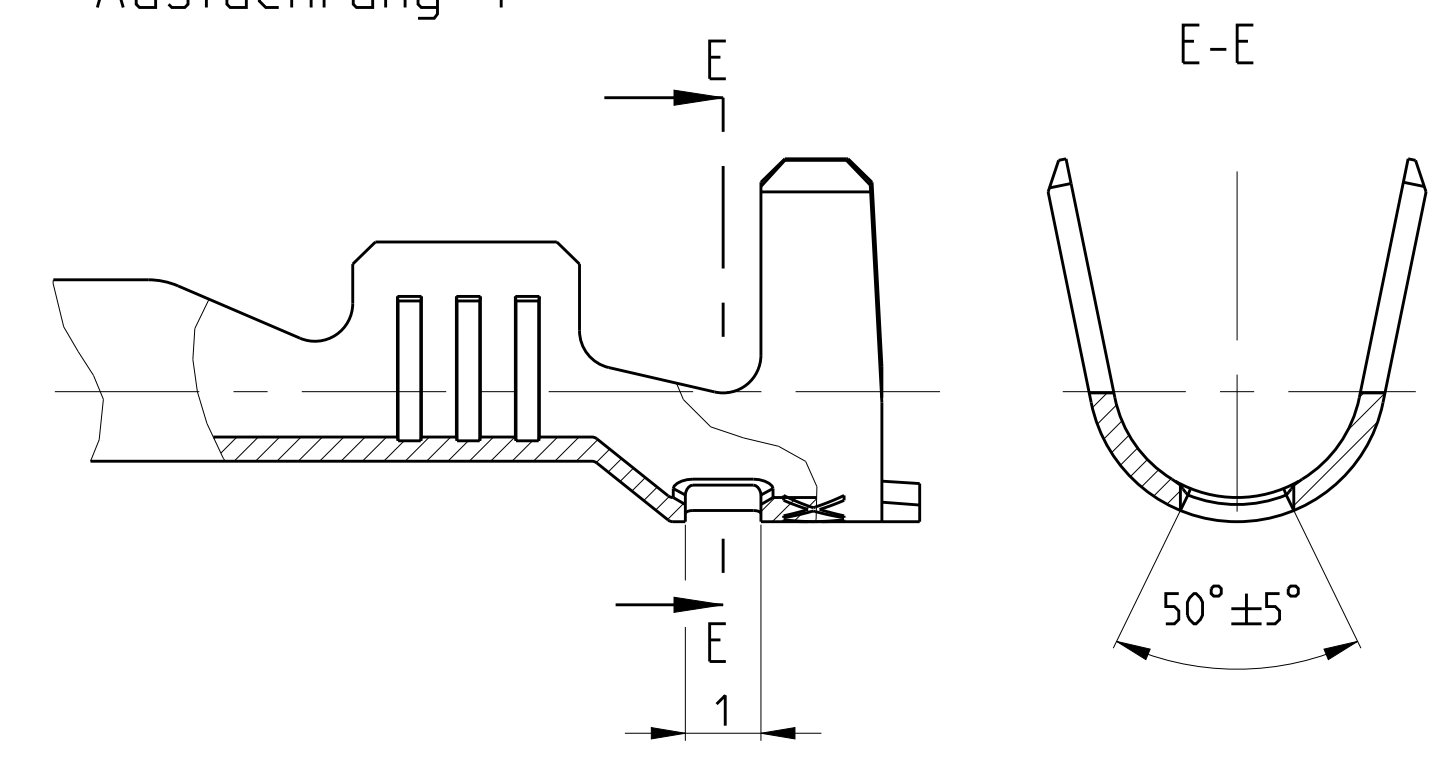

DESIGN 2 Ausfuehrung 2

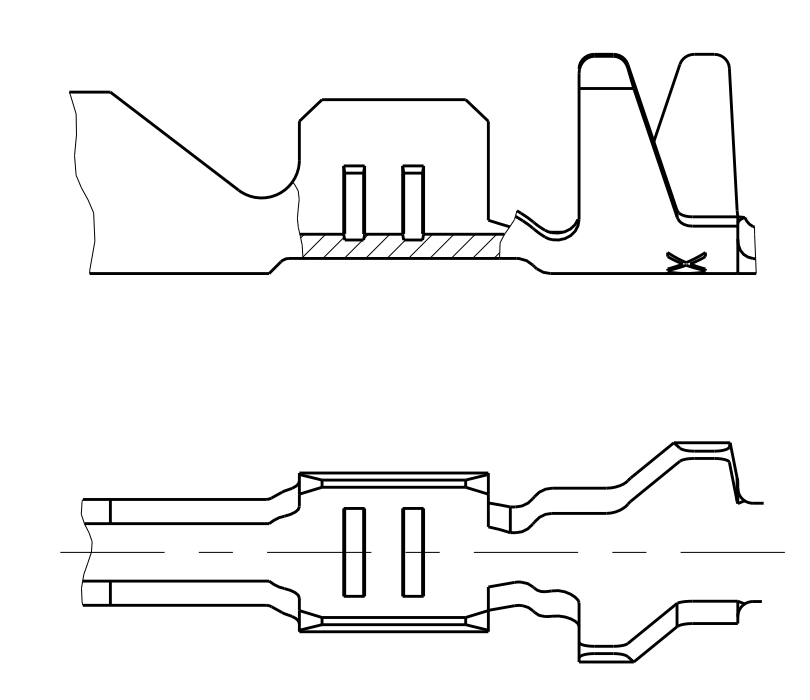

DESIGN 5 Ausfuehrung 5

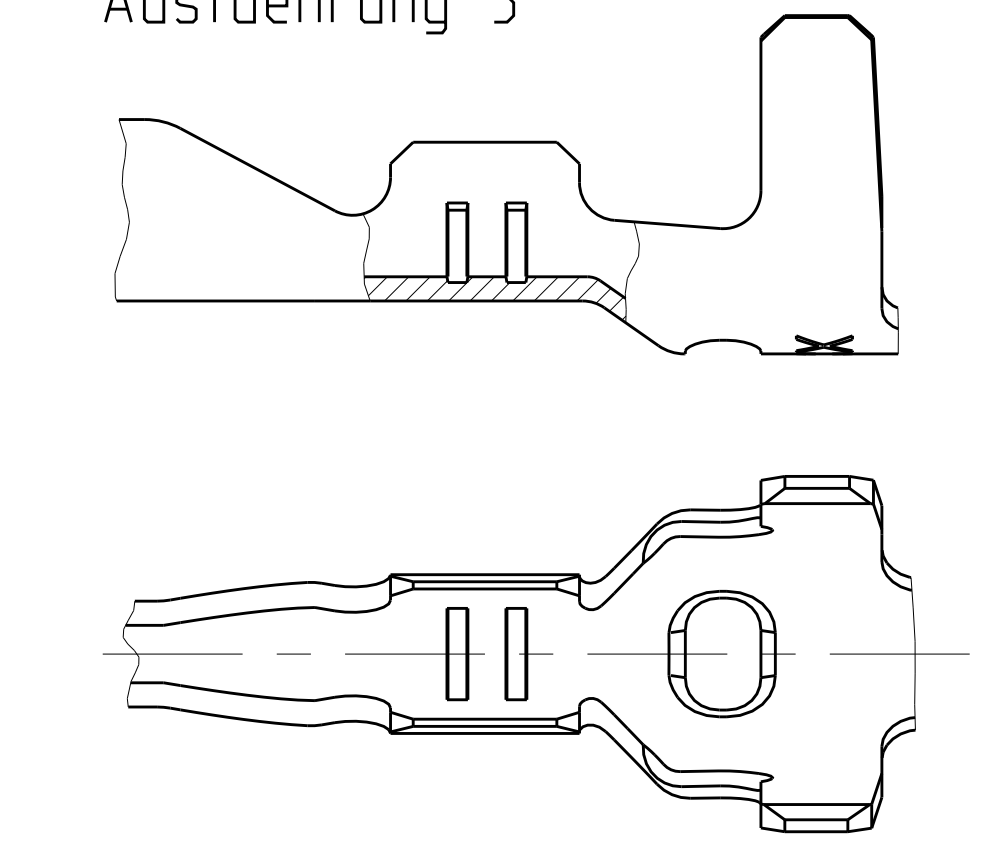

DESIGN 3 Ausfuehrung 3

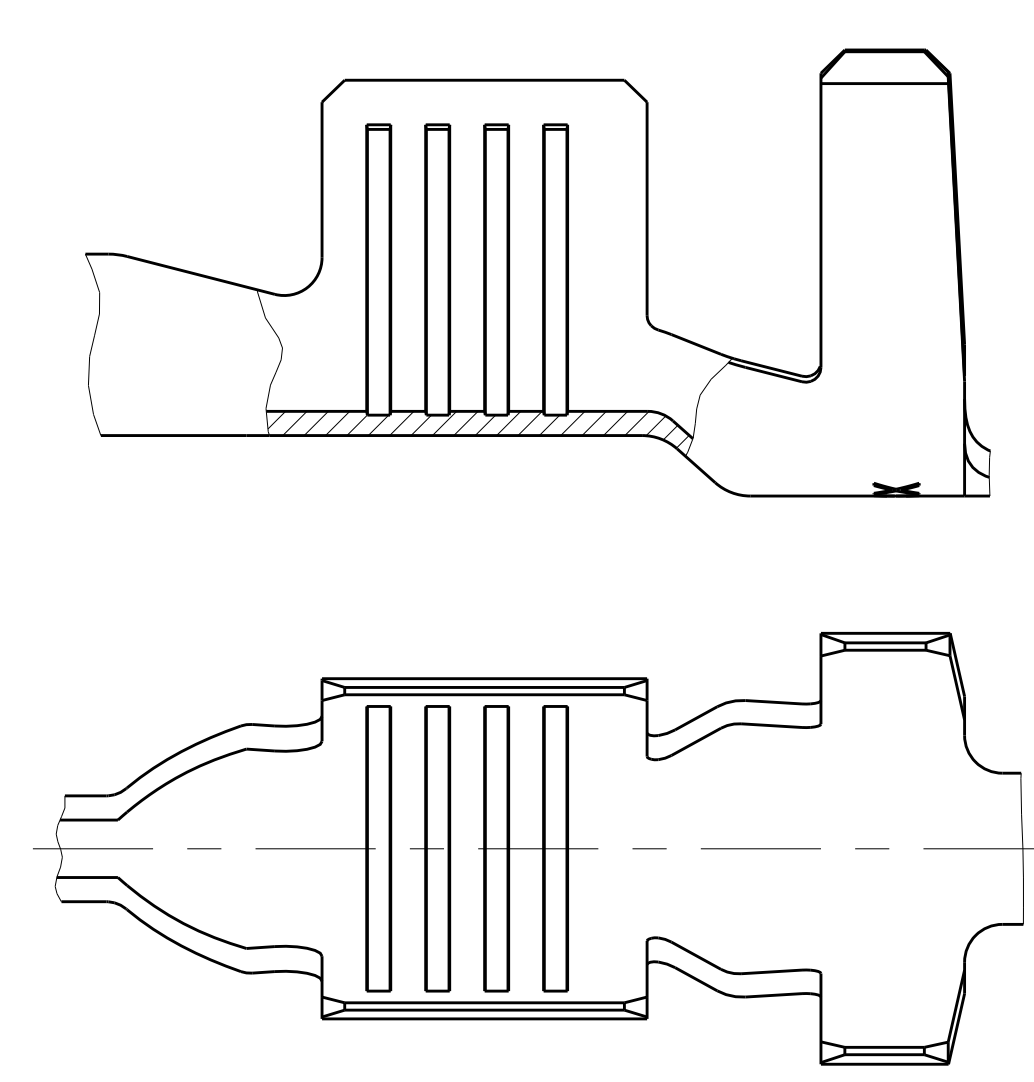

DESIGN 6 Ausfuehrung 6

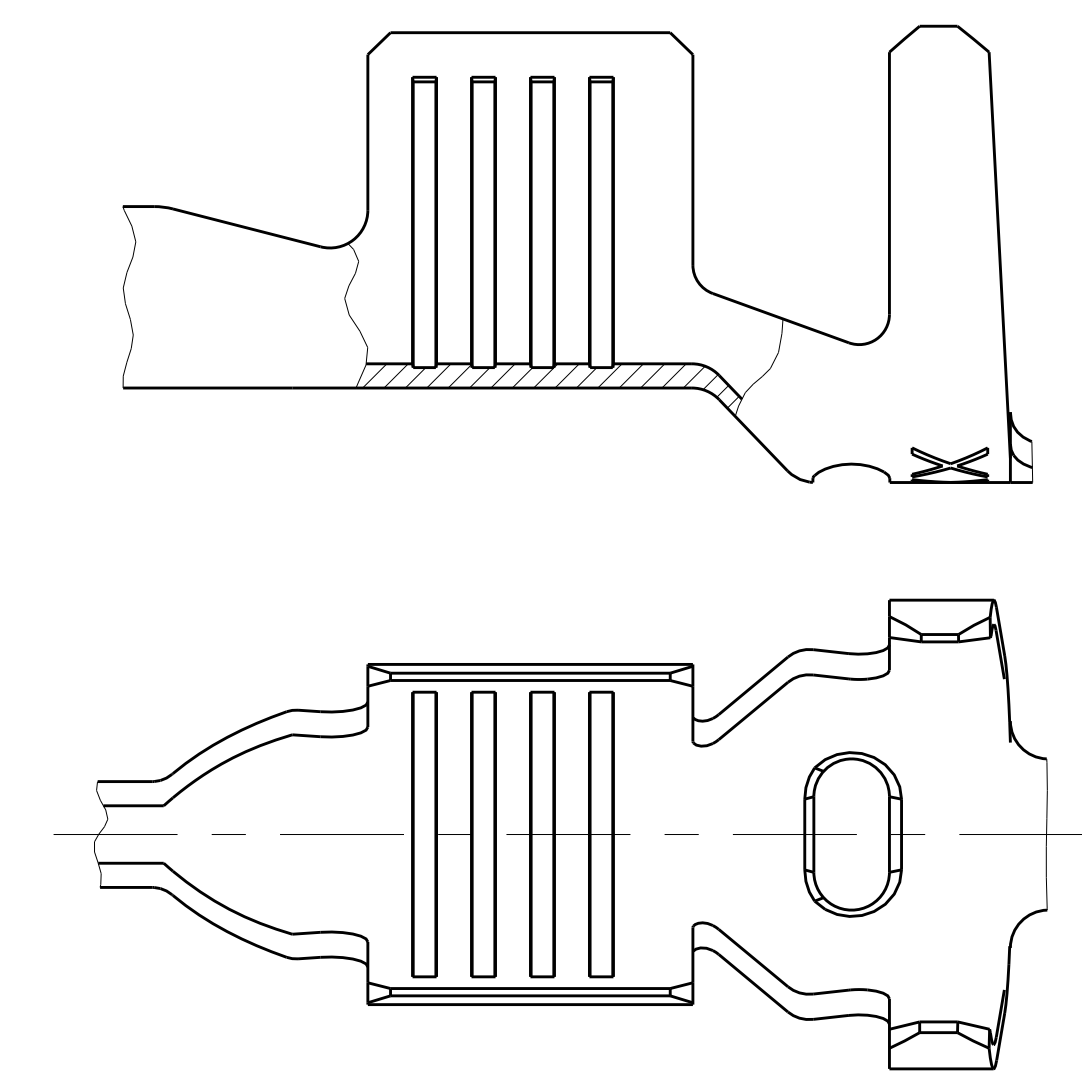

DESIGN 7 Ausfuehrung 7

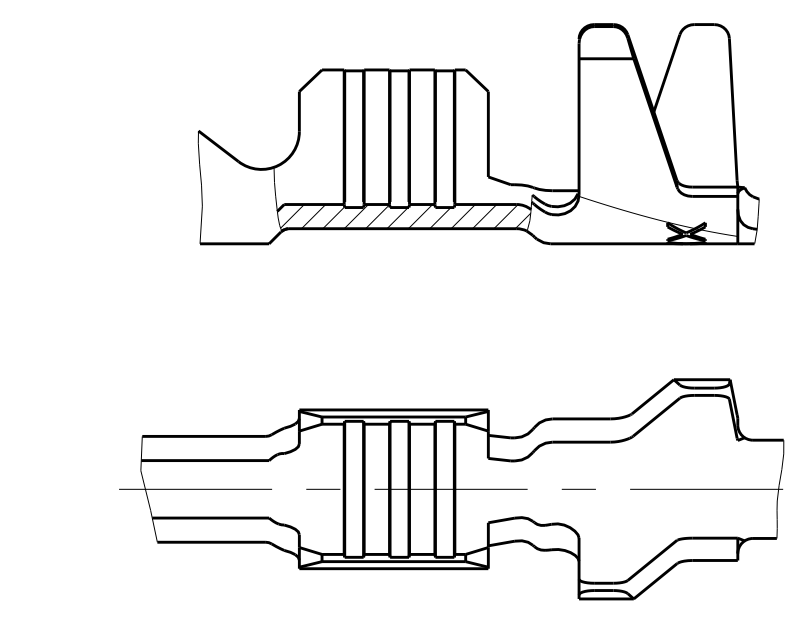

DESIGN 8 Ausfuehrung 8

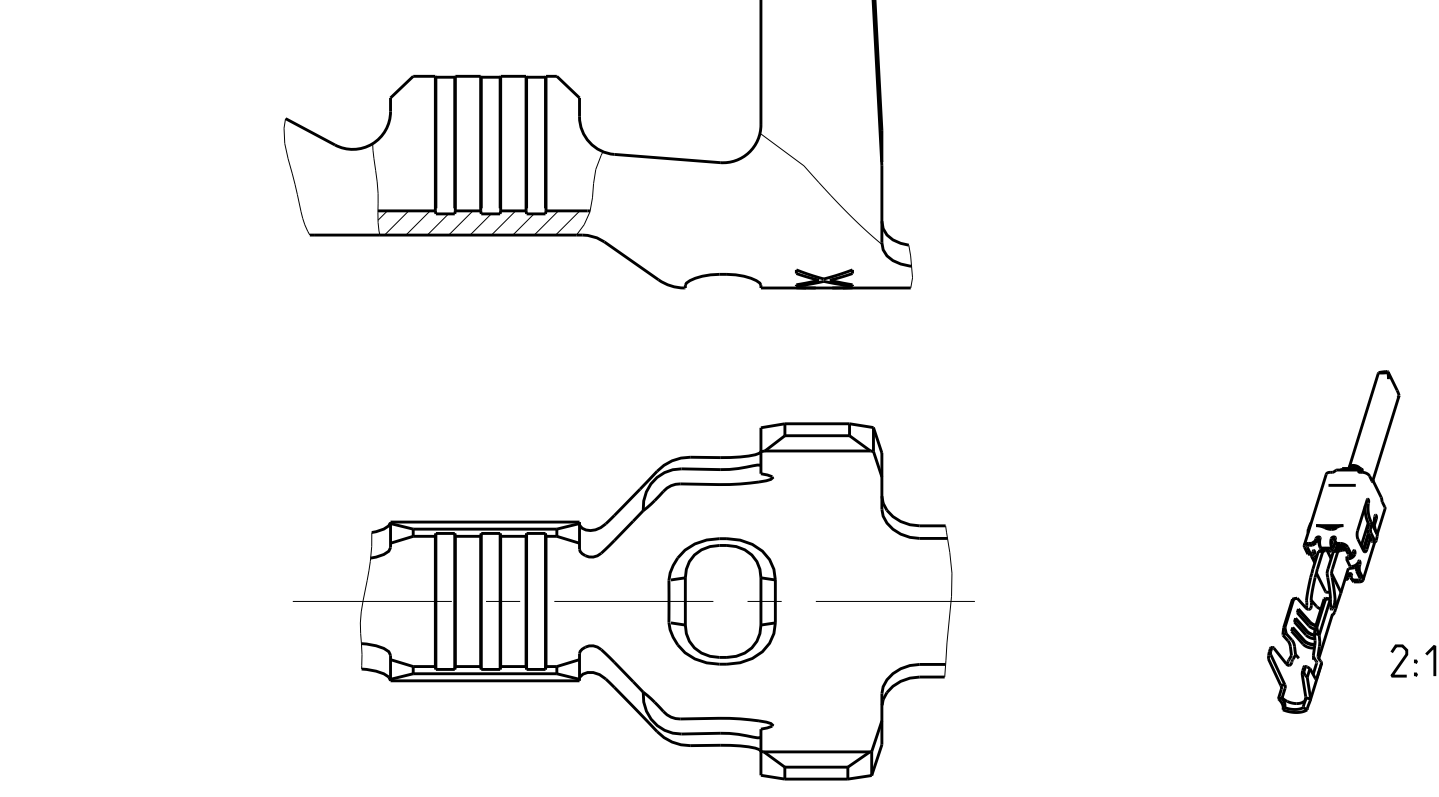

SINGLE WIRE SEAL / Einzeldichtungssystem	REV	DESIGN	MATERIAL	SURFACE	DGB	INSULATION	SEE / siehe SECTION A-A Schnitt A-A	SEE / siehe SECTION B-B Schnitt B-B	APPLICATION TOOL	HAND TOOL	TE	TE			
							A	B							
SINGLE WIRE SEAL / Einzeldichtungssystem	1-1719504-2	A	4	CuSn4	12 AWG	max. 3.0	E = 4.0 G = 4.2 D _{Dr} = 2.0	H = 5.3 K = 5.0 D = 3.6	1852291-3	-	3.5	6.0	7.6	26.8	828922-1
	1-1719504-1	A	4	CuSn0.20	FLR	max. 3.7	E = 4.5 G = 4.7 D _{Dr} = 2.3	H = 6.2 K = 6.0 D = 4.3	MQC APPLICATOR 2-541537-2	539635-1 MATRIZE : 539727-2	4.3	6.9	8.5	28.5	828985 (Ø6.4) 828986-1
	2-968947-2	A	6	CuFe	FLR	max. 3.0	E = 3.6 G = 3.8 D _{Dr} = 1.7	H = 5.3 K = 5.0 D = 3.6	MQC APPLICATOR 2-878560-2	734440-1	3.5	6.0	7.6	26.8	828905 (Ø5.0)
	1-968947-2	A	6	CuSn4	FLR	max. 2.1	E = 2.6 G = 2.9 D _{Dr} = 1.2	H = 5.0 K = 4.8 D = 3.3	MQC APPLICATOR 2-878559-2	734438-1	3.0	5.4	7.0	26.8	828904 (Ø5.0)
	2-962916-3	E	4	CuFe	FLR	max. 2.1	E = 2.1 G = 2.1 D _{Dr} = 0.8	H = 4.7 K = 4.5 D = 3.2	MQC APPLICATOR 2-878558-2	539635-1 MATRIZE : 539737-2	2.5	4.9	6.5	26.8	828904 (Ø5.0)
	2-968946-2	A	3	CuFe	FLR	2.7 - 3.7	E = 4.5 G = 4.7 D _{Dr} = 2.3	H = 5.7 K = 5.9 D = 3.3	MQC APPLICATOR 2-541534-2	539635-1 MATRIZE : 539723-2	4.3	6.6	8.5	28.5	828922-1
	1-968946-2	A	3	CuSn4	FLK	2.4 - 3.7	E = 3.6 G = 3.8 D _{Dr} = 1.7	H = 5.5 K = 5.7 D = 3.2	MQC APPLICATOR 2-878552-2	734417-3	3.6	5.2	8.9	28.6	
	2-962843-3	C	1	CuFe	FLR	2.1 - 2.9	E = 3.6 G = 3.8 D _{Dr} = 1.7	H = 4.3 K = 4.5 D = 2.6	MQC APPLICATOR 2-878551-2	734417-2	3.6	5.2	8.2	27.9	
	1-962843-2	C	1	CuSn4	FLR	1.4 - 2.1	E = 2.6 G = 2.8 D _{Dr} = 1.1	H = 3.2 K = 3.4 D = 1.8	MQC APPLICATOR 2-878550-2	734417-1	3.0	4.6	7.0	26.7	
	2-963860-3	B	2	CuFe	FLR	1.3 - 1.6	E = 2.1 G = 2.1 D _{Dr} = 0.8	H = 2.9 K = 2.9 D = 1.4	MQC APPLICATOR 2-878549-2	734538-1	2.5	3.7	5.8	25.5	
	1-963860-3	B	2	CuSn4	FLR										

TE	DESIGN	MATERIAL	SURFACE	DGB	INSULATION	STRIP FORM WIRE CRIMP Drahtcrimp	INSUL. CRIMP Isolationscrimp	APPLICATION TOOL Anschtagerwerkzeug	HAND TOOL Handzange	TE	TE
ORDER-NO.	REV	Ausfuehrung	Werkstoff	mm ²	mm	CRIMP DIMENSION mm Crimpabmessungen mm		EXTRACTION TOOL Ausdruckwerkzeug No. 968107-1		ORDER-NO. SINGLE WIRE SEAL Einzeldichtungssystem (CAVITY DIAMETER) (Kammerdurchmesser)	ORDER-NO. SEALING PLUG Blindstopfen
Bandware			Oberflaeche							A	B

THIS DRAWING IS A CONTROLLED DOCUMENT. DATE: 14 JUN 1999. BY: K. Gerlach. CH: M. Bleicher.

PRODUCT GROUP DRAWING FOR TAB 2.8x0.8
Produktgruppenzeichnung fuer
Flachstecker 2.8x0.8

SCALE: 10:1. SHEET: 1 OF 1. REV: A1B