

MPCB's MPX³

Cat. N°(s) : 4 173 00...4 173 15, 4 173 20...4 173 35,
4 173 40...4 173 55, 4 173 60...4 173 68,
4 173 70...4 173 79



| CONTENTS | PAGES |
|--------------------------------------|-------|
| 1. Description - Use | 1 |
| 2. Range..... | 1 |
| 3. Overall dimensions | 1 |
| 4. Installation - Connection..... | 2 |
| 5. General characteristics | 3 |
| 6. Conformities and approvals | 12 |
| 7. Curves | 13 |
| 8. Auxiliaries and accessories | 23 |

1. DESCRIPTION - USE

Thermal-magnetic circuit breaker with positive contact indication for control, protection and isolation of electrical circuits supplying electrical motors.

Symbol:

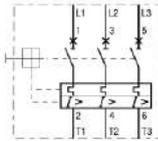

2. RANGE

Number of Poles:

. Triple pole (3P).

Rated current In:

. 0.16A, 0.25A, 0.4A, 0.63A, 1A, 1.6A, 2.5A, 4A, 6A, 8A, 10A, 13A, 17A, 22A, 26A, 32A, 40A, 50A, 63A, 75A, 90A, 100A.

Magnetic threshold:

. 13 Ie Max

Rated Voltage / Frequency:

. 400 / 415 V ~, 50 / 60 Hz with standard tolerances.

Operating voltage:

. 230 / 240 V ~.
. 400 / 415 V ~.
. 440 / 460 V ~.
. 500 / 525 V ~.
. 600 / 690 V ~.

Thermal tripping class:

. Class 10A in accordance with IEC 60 947.

Utilisation category:

. Category A in accordance with IEC 60947-2.
. Category A C-3 in accordance with IEC 60947-4-1.

Suitability for isolation:

. In accordance with IEC 60947-1.

3. OVERALL DIMENSIONS

MPX³ 32S:

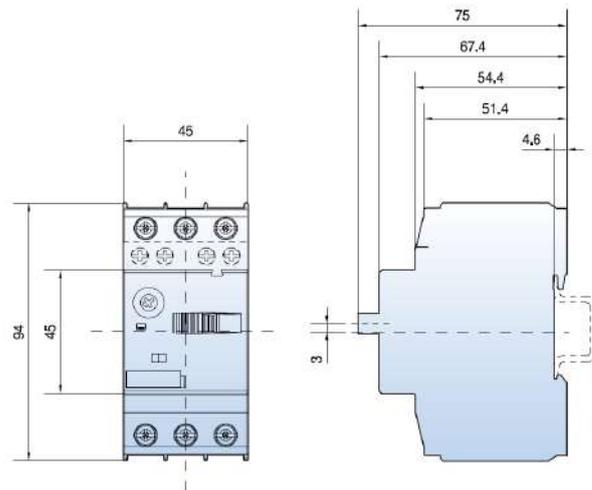

MPX³ 32H / MPX³ 32MA:

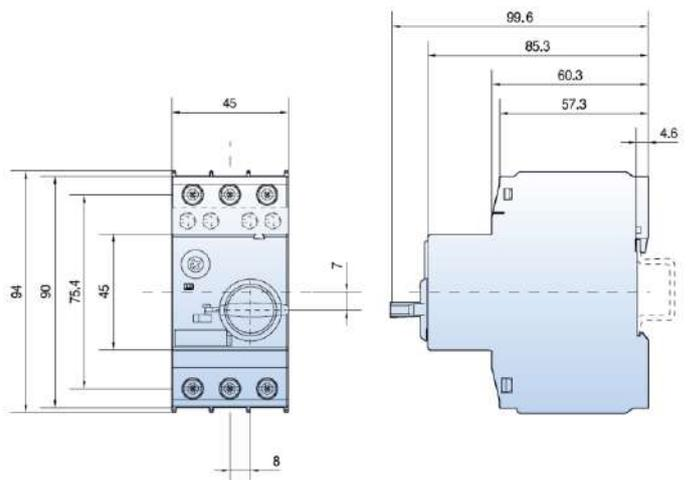

3. OVERALL DIMENSIONS (continued)

MPX³ 63H:

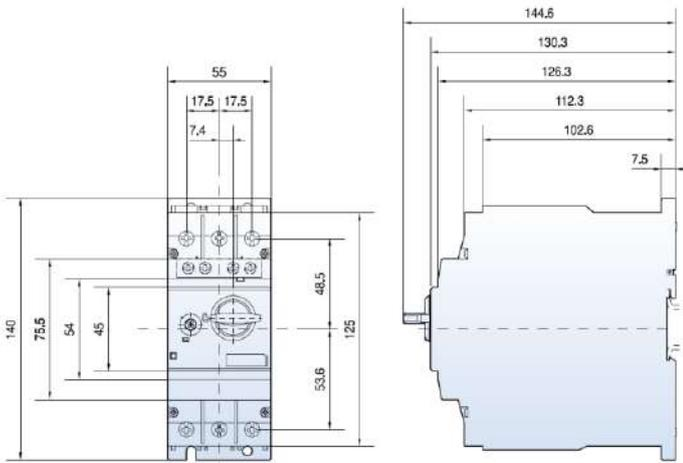

MPX³ 100H:

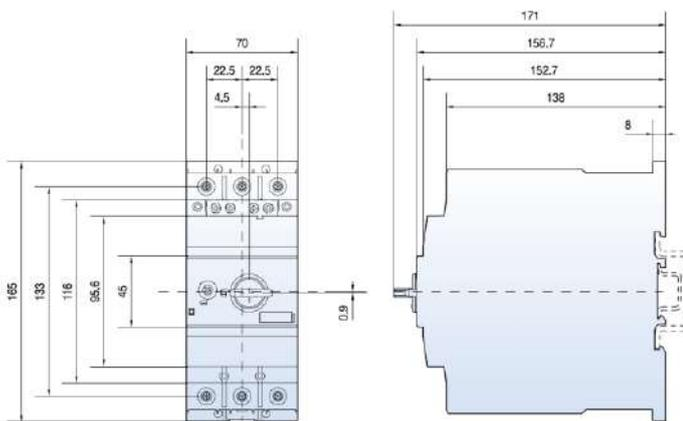

4. INSTALLATION - CONNECTION

Fixing:

- . 35mm DIN rail for MPX³ 32S / MPX³ 32H / MPX³ 32MA.
- . 35mm DIN rail for MPX³ 63H, or with screws.
- . 35mm or 75 mm DIN rail for MPX³ 100H, or with screws.
- use 15 mm depth for 35 mm DIN rail

Operating position:

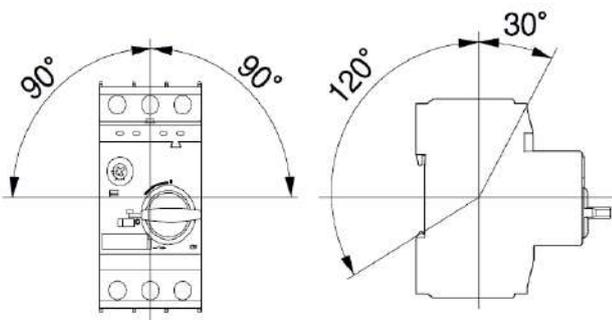

4. INSTALLATION - CONNECTION (continued)

Supply:

- . Either from the top or the bottom.

Type of wire:

- . For MPX³ 32S / MPX³ 32H / MPX³ 32MA

| | MPX ³ 32S | MPX ³ 32H MPX ³ 32MA |
|-------------------|---|---|
| Terminal parts | | |
| Single-core | 1.conductor [mm ²] / [AWG] 1...10 / 18...8 2.conductor [mm ²] / [AWG] 1...6 / 18...10 | 1...10 / 18...8 1...6 / 18...10 |
| Standard | 1.conductor [mm ²] / [AWG] 1...6 / 18...10 2.conductor [mm ²] / [AWG] 1...6 / 18...10 | 1...6 / 18...10 1...6 / 18...10 |
| Flexible | 1.conductor [mm ²] / [AWG] 1...6 / 18...10 2.conductor [mm ²] / [AWG] 0.75...4 / 18...10 | 1...6 / 18...10 0.75...4 / 18...10 |
| Tightening torque | [Nm] / [lb-in] 0.8...2.5 / 7...22 | 0.8...2.5 / 7...22 |

- . For MPX³ 63H / MPX³ 100H

| | MPX ³ 63H | MPX ³ 100H |
|-------------------|--|--|
| Terminal parts | | |
| Single-core | 1.conductor [mm ²] / [AWG] 0.75...35 / 18...2 2.conductor [mm ²] / [AWG] 0.75...25 / 18...4 | 2.5...70 / 12...2/0 2.5...50 / 12...1/0 |
| Standard | 1.conductor [mm ²] / [AWG] 0.75...35 / 18...2 2.conductor [mm ²] / [AWG] 0.75...25 / 18...4 | 2.5...70 / 12...2/0 2.5...50 / 12...1/0 |
| Flexible | 1.conductor [mm ²] / [AWG] 0.75...25 / 18...4 2.conductor [mm ²] / [AWG] 0.75...16 / 18...6 | 2.5...50 / 12...1/0 2.5...35 / 10...2 |
| Tightening torque | [Nm] / [lb-in] 3...4.5 / 26...39 | 4...6 / 35...53 |

Connection :

- . Terminals protected against direct contact (IP20).
- . Terminals with release and captive screws.
- . Screw head : slotted and pozidriv n°2.
(for MPX³ 32S, 32H, 32MA and MPX³ 63H)
- . Allen key 4 [mm] (for MPX³ 100H).

Tools required:

- . Posidriv N°2 screwdriver recommended.
- . Flat screwdriver Ø5 to Ø6 [mm] Maximum.

Manual actuation:

- . Ergonomic 2 positions rocker: (for MPX³ 32S)
- . Ergonomic 2 positions rotary handle: (for MPX³ 32H / MPX³ 32MA and MPX³ 63H)
 - O : Device open.
 - I : Device closed.
- . Ergonomic 3 positions rotary handle: (for MPX³ 100H)
 - O : Device open.
 - TRIP : Device open.
 - I : Device closed.

4. INSTALLATION - CONNECTION *(continued)*

Contact status display:

- . For MPX³ 32S / MPX³ 32H / MPX³ 32MA and MPX³ 63H
 - By permanent laser marking:
 - . "O-OFF" = contacts open.
 - . "I-ON" = contacts closed.
- . For MPX 100H:
 - By permanent laser marking:
 - . "O-OFF" = contacts open.
 - . "TRIP" = contacts open (indication on current fault).
 - . "I-ON" = contacts closed.

Sealing:

- . With dial Cover MPX³ (cat n° 4 174 79).

Locking possibility:

- . By 4.5 [mm] padlock, in the open position - "OFF".

Labelling:

- . Identification labelling area situated on the front of the product.

5. GENERAL CHARACTERISTICS

Front side:

- . By permanent laser marking:

- Brand: Legrand
- Range: MPX³
- Rated current (in A)
- O Off / ON I
- TEST
- Electric diagram
- Thermal adjustment ring
- Ultimate short-circuit breaking capacity (Icu)
- Rated service short-circuit breaking capacity (Ics)
- Marking power terminals

MPX³ 32S: (Example of marking)

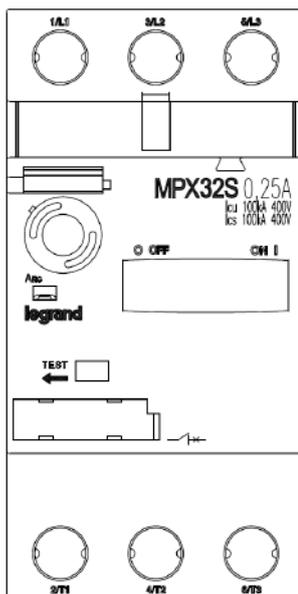

5. GENERAL CHARACTERISTICS *(continued)*

Front side: *(continued)*

MPX³ 32H: (Example of marking)

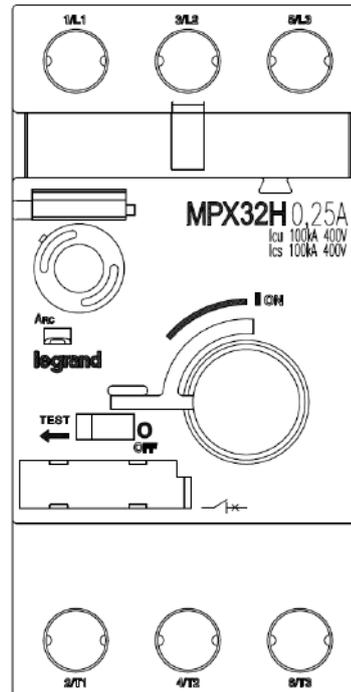

MPX³ 32MA: (Example of marking)

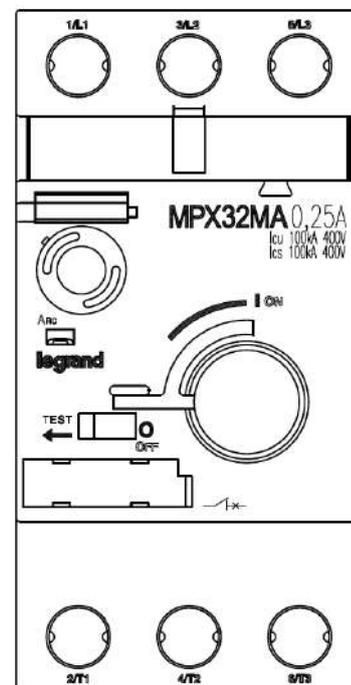

5. GENERAL CHARACTERISTICS (continued)

Front side: (continued)

MPX³ 63H: (Example of marking)

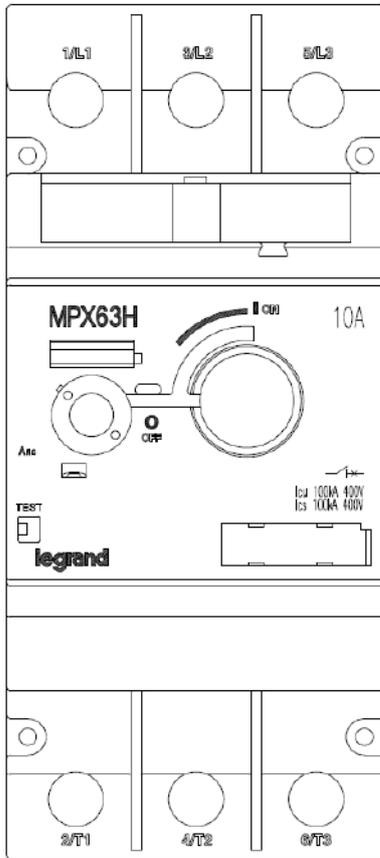

MPX³ 100H: (Example of marking)

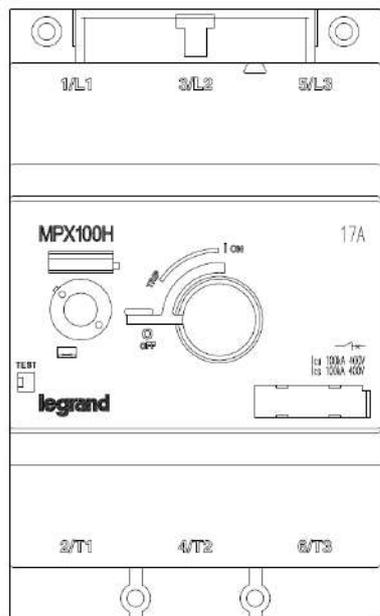

5. GENERAL CHARACTERISTICS (continued)

Front side: (continued)

Left side:

. By identification label (referring to IEC standard)

legrand MPX³ 4 173 00

Cat.A / AC-3 $U_i = 690V$ 50/60Hz $U_{imp} = 6kV$
 $I_e = 0.1-0.16A$ $I_n >> 2.1A$ Trip Class 10

| U_e (V) | I_{cu} (kA) | I_{cs} (kA) | $I_{cc} > I_{cu}$ gL / gG |
|--------------|------------------|------------------|------------------------------|
| 230 / 240 | 100 | 100 | - |
| 400 / 415 | 100 | 100 | - |
| 440 / 460 | 100 | 100 | - |
| 500 / 525 | 100 | 100 | - |
| 600 / 690 | 100 | 100 | - |

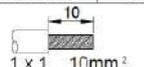

1 x 1 ... 10mm²
2 x 1 ... 6mm²

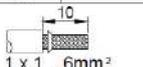

1 x 1 ... 6mm²
2 x 1 ... 6mm²

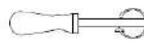
 PZ2/Ø 5...6mm
2.0Nm

IEC/EN 60947 VDE 0660

CE

140626 YS

MADE IN KOREA

Right side:

. By identification label (referring to UL standard)

MANUAL MOTOR CONTROLLER 

MAX. FUSE OR CB 500A

SHORT CIRCUIT CURRENT RATING,
RMS, SYM: 50kA 480V/277V, 10kA 600V/347V

| V AC | 115 | 200 | 230 | 460 | 575 |
|---------|-----|-----|-----|-----|-----|
| 3PH, HP | - | - | - | - | 1/2 |
| 1PH, HP | - | - | - | - | - |

SUITABLE FOR USE WITH LOAD SIDE CONTROLLERS MARKED FOR USE WITH THIS PRODUCT.
 FOR USE WITH DESIGN E MOTORS.
 USE ALL 3 POLES
 1.0 FLA MAX; DIAL IS FLA. TRIP AMPS 125%
 USE 75°C CU WIRE ONLY; BREAK ALL LINES

| TORQUE | WIRE RANGE |
|---------|-----------------------------------|
| 18LB IN | 1x 18 TO 8 AWG 2x 18 TO 10 AWG |

7951 1912 035

WARNING:
 IF AN OVERLOAD OR A FAULT CURRENT INTERRUPTION OCCURS, CIRCUITS MUST BE CHECKED TO DETERMINE THE CAUSE OF THE INTERRUPTION. IF A FAULT CONDITION EXISTS, THE CURRENT-CARRYING COMPONENTS SHOULD BE EXAMINED AND REPLACED IF DAMAGED, AND THE INTEGRAL CURRENT SENSORS MUST BE REPLACED TO REDUCE THE RISK OF FIRE OR ELECTRIC SHOCK. TO MAINTAIN OVERCURRENT, SHORT-CIRCUIT, AND GROUND-FAULT PROTECTION, THE MANUFACTURER'S INSTRUCTIONS FOR SELECTION OF OVERLOAD AND SHORT CIRCUIT PROTECTION MUST BE FOLLOWED TO REDUCE THE RISK OF FIRE OR ELECTRIC SHOCK.

5. GENERAL CHARACTERISTICS (continued)

Setting ranges:

| Rated operational current (I _e) | Thermal release adjustment range (I _r) |
|---|--|
| 0.16 [A] | 0.1~0.16 [A] |
| 0.25 [A] | 0.16~0.25 [A] |
| 0.4 [A] | 0.25~0.4 [A] |
| 0.63 [A] | 0.4~0.63 [A] |
| 1 [A] | 0.63~1 [A] |
| 1.6 [A] | 1~1.6 [A] |
| 2.5 [A] | 1.6~2.5 [A] |
| 4 [A] | 2.5~4 [A] |
| 6 [A] | 4~6 [A] |
| 8 [A] | 5~8 [A] |
| 10 [A] | 6~10 [A] |
| 13 [A] | 9~13 [A] |
| 17 [A] | 11~17 [A] |
| 22 [A] | 14~22 [A] |
| 26 [A] | 18~26 [A] |
| 32 [A] | 22~32 [A] |
| 40 [A] | 28~40 [A] |
| 50 [A] | 34~50 [A] |
| 63 [A] | 45~63 [A] |
| 75 [A] | 55~75 [A] |
| 90 [A] | 70~90 [A] |
| 100 [A] | 80~100 [A] |

Rated operational voltage:

- . U_e = 690 [V] for all products conforming to IEC60947-2.
- . U_e = 600 [V] for all products conforming to UL508

Rated impulse voltage:

- . U_{imp} = 6 kV for MPX³ 32S / MPX³ 32H / MPX³ 32MA.
- . U_{imp} = 8 kV for MPX³ 63H / MPX³ 100H.

Rated insulation voltage:

- . U_i = 690 V for MPX³ 32S / MPX³ 32H / MPX³ 32MA.
- . U_i = 1000 V for MPX³ 63H / MPX³ 100H.

Mechanical endurance:

- . 100 000 operations for MPX³ 32S / MPX³ 32H / MPX³ 32MA.
- . 50 000 operations for MPX³ 63H / MPX³ 100H.

Electrical endurance:

- . 100 000 cycles for MPX³ 32S / MPX³ 32H / MPX³ 32MA.
- . 25 000 cycles for MPX³ 63H / MPX³ 100H.

Max operating frequency per hour:

- . 25 operations per hour.

5. GENERAL CHARACTERISTICS (continued)

Ambient operating temperature:

- . Min. = -20°C. Max. = +60°C.

Ambient storage temperature:

- . Min. = -50°C. Max. = +80°C.

Overload protection:

- . No overload protection for MPX³ 32MA.

Phase failure protection:

- . All products.

Test function:

- . All products.

Weight:

| MPX ³ | Weight |
|-----------------------|-----------|
| MPX ³ 32S | 0.32 [kg] |
| MPX ³ 32H | 0.36 [kg] |
| MPX ³ 32MA | 0.36 [kg] |
| MPX ³ 63H | 1 [kg] |
| MPX ³ 100H | 2.2 [kg] |

Maximum operating altitude:

- . 2000 [m].

Protection degree:

- . IP20.

Flame resistance:

- . Conforming to UL = V0.
- . Conforming to IEC 695-2-1 = 960 [°C].

Shock resistance:

- . 25 [g].

Vibration resistance:

- . 5~150 [Hz].

Power consumption:

| | MPX ³ 32S | MPX ³ 32H / MA |
|--|--|--|
| Total power loss circuit breaker at rated load operating temperature | I _n = 0.16~1.6 [A] 4.4 [W] | I _n = 0.16~1.6 [A] 4.4 [W] |
| | I _n = 2.5~26 [A] 7.4 [W] | I _n = 2.5~26 [A] 7.4 [W] |
| | I _n = 32 [A] 4 [W] | I _n = 32 [A] 4 [W] |
| Total power loss circuit breaker at rated load operating temperature | MPX ³ 63H | MPX ³ 100H |
| | I _n = 10~22 [A] 10.2 [W] | I _n = 17~32 [A] 15 [W] |
| | I _n = 26~63 [A] 9.7 [W] | I _n = 40~63 [A] 21.8 [W] |
| | - | I _n = 75~100 [A] 17.8 [W] |

5. GENERAL CHARACTERISTICS (continued)

Breaking capacity: In accordance with IEC 60 947-2 standard
. For MPX³ 32S

| Rated operational current - Ie [A] | | | 0.16 | 0.25 | 0.4 | 0.63 | 1 | 1.6 | 2.5 | 4 | 6 | 8 | 10 | 13 | 17 | 22 | 26 | 32 |
|--|---------------|------|------|------|------|------|---------------|---------------|------|---------------|-------------|-----|-------|-----|-------|-----|------|------|
| Switching of standard three-phase motors AC-2, AC-3 | 230 / 240 [V] | [kW] | - | 0.03 | 0.06 | 0.09 | 0.12 | 0.18/ 0.25 | 0.37 | 0.55/ 0.75 | 1.1/ 1.5 | 1.5 | 2.2/3 | 3 | 3.7/4 | 4 | 5.5 | 7.5 |
| | 400 / 415 [V] | [kW] | 0.02 | 0.06 | 0.09 | 0.12 | 0.18/ 0.25 | 0.37/ 0.55 | 0.75 | 1.1/ 1.5 | 2.2 | 3 | 3.7/4 | 5.5 | 7.5 | 7.5 | 11 | 15 |
| | 500 [V] | [kW] | - | - | - | 0.25 | 0.37 | 0.55/ 0.75 | 1.1 | 1.5/ 2.2 | 3 | 3.7 | 4/5.5 | 7.5 | 11 | 11 | 15 | 18.5 |
| | 690 [V] | [kW] | - | - | - | 0.25 | 0.37/ 0.55 | 0.75/ 1.1 | 1.5 | 2.2/3 | 3.7/4 | 5.5 | 7.5 | 11 | 11 | 15 | 18.5 | 22 |
| Ultimate short-circuit breaking capacity (Icu) | 230 / 240 [V] | [kA] | 100 | 100 | 100 | 100 | 100 | 100 | 100 | 100 | 100 | 100 | 100 | 100 | 50 | 40 | 40 | 30 |
| | 400 / 415 [V] | [kA] | 100 | 100 | 100 | 100 | 100 | 100 | 100 | 100 | 100 | 100 | 50 | 50 | 20 | 15 | 15 | 15 |
| | 440 / 460[V] | [kA] | 100 | 100 | 100 | 100 | 100 | 100 | 100 | 50 | 15 | 15 | 15 | 10 | 10 | 8 | 8 | 6 |
| | 500 [V] | [kA] | 100 | 100 | 100 | 100 | 100 | 100 | 50 | 15 | 10 | 10 | 6 | 6 | 6 | 6 | 5 | 5 |
| Rated service short-circuit breaking capacity (Ics) | 230 / 240 [V] | [kA] | 100 | 100 | 100 | 100 | 100 | 100 | 100 | 100 | 100 | 100 | 100 | 100 | 38 | 30 | 30 | 22 |
| | 400 / 415 [V] | [kA] | 100 | 100 | 100 | 100 | 100 | 100 | 100 | 100 | 100 | 100 | 38 | 38 | 15 | 11 | 11 | 11 |
| | 440 / 460[V] | [kA] | 100 | 100 | 100 | 100 | 100 | 100 | 100 | 38 | 11 | 11 | 11 | 8 | 8 | 6 | 6 | 4 |
| | 500 [V] | [kA] | 100 | 100 | 100 | 100 | 100 | 100 | 38 | 11 | 8 | 8 | 5 | 5 | 5 | 5 | 4 | 4 |
| Rated service short-circuit breaking capacity of one single pole | 230 / 240 [V] | [kA] | 100 | 100 | 100 | 100 | 100 | 100 | 100 | 100 | 100 | 100 | 38 | 38 | 15 | 11 | 11 | 11 |
| | 400 / 415 [V] | [kA] | 100 | 100 | 100 | 100 | 100 | 3 | 3 | 3 | 3 | 3 | 3 | 3 | 3 | 3 | 3 | 3 |

. In accordance with UL 508 certification

| Rated operational current - Ie [A] | | | 0.16 | 0.25 | 0.4 | 0.63 | 1 | 1.6 | 2.5 | 4 | 6 | 8 | 10 | 13 | 17 | 22 | 26 | 32 |
|------------------------------------|---------|------|------|------|-----|------|-----|------|-------|-----|-------|-----|-------|-------|----|-------|-------|-------|
| Max. short-circuit current | | | | | | | | | | | | | | | | | | |
| | 240 [V] | [kA] | 100 | 100 | 100 | 100 | 100 | 100 | 100 | 100 | 100 | 100 | 50 | 50 | 40 | 30 | 30 | 20 |
| | 480 [V] | [kA] | 50 | 50 | 50 | 50 | 50 | 50 | 50 | 50 | 50 | 25 | 25 | 10 | 10 | 10 | 7.5 | 7.5 |
| | 600 [V] | [kA] | 10 | 10 | 10 | 10 | 10 | 10 | 10 | 10 | 5 | 5 | 5 | 5 | 5 | 5 | 5 | 5 |
| Motor load | | | | | | | | | | | | | | | | | | |
| 1 Phase | 115 [V] | [HP] | - | - | - | - | - | - | - | 1/8 | 1/4 | 1/3 | 1/2 | 1/2 | 1 | 1 1/2 | 2 | 2 |
| | 230 [V] | [HP] | - | - | - | - | - | 1/10 | 1/6 | 1/3 | 1/2 | 1 | 1 1/2 | 2 | 3 | 3 | 3 | 5 |
| 3 Phase | 200 [V] | [HP] | - | - | - | - | - | - | 1/2 | 3/4 | 1 | 2 | 2 | 3 | 3 | 5 | 7 1/2 | 7 1/2 |
| | 230 [V] | [HP] | - | - | - | - | - | - | 1/2 | 3/4 | 1 1/2 | 2 | 3 | 3 | 5 | 7 1/2 | 7 1/2 | 10 |
| | 460 [V] | [HP] | - | - | - | - | - | 3/4 | 1 | 2 | 3 | 5 | 5 | 7 1/2 | 10 | 15 | 15 | 20 |
| | 575 [V] | [HP] | - | - | - | - | 1/2 | 3/4 | 1 1/2 | 3 | 5 | 5 | 7 1/2 | 10 | 15 | 20 | 20 | 30 |
| Max. Fuse size | | [A] | 1 | 1 | 1 | 1 | 3 | 6 | 10 | 15 | 20 | 30 | 40 | 50 | 60 | 80 | 100 | 125 |
| Max. Breaker size | | [A] | 15 | 15 | 15 | 15 | 15 | 15 | 15 | 15 | 20 | 30 | 40 | 50 | 60 | 80 | 100 | 125 |

5. GENERAL CHARACTERISTICS *(continued)*

Breaking capacity: In accordance with IEC 60 947-2 standard

. For MPX³ 32H and 32MA

| Rated operational current - I _e [A] | | 0.16 | 0.25 | 0.4 | 0.63 | 1 | 1.6 | 2.5 | 4 | 6 | 8 | 10 | 13 | 17 | 22 | 26 | 32 |
|--|--------------------|------|------|------|------|---------------|---------------|------|---------------|-------------|-----|-------|-----|-------|-----|------|------|
| Switching of standard three-phase motors AC-2, AC-3 | 230 / 240 [V] [kW] | - | 0.03 | 0.06 | 0.09 | 0.12 | 0.18/ 0.25 | 0.37 | 0.55/ 0.75 | 1.1/ 1.5 | 1.5 | 2.2/3 | 3 | 3.7/4 | 4 | 5.5 | 7.5 |
| | 400 / 415 [V] [kW] | 0.02 | 0.06 | 0.09 | 0.12 | 0.18/ 0.25 | 0.37/ 0.55 | 0.75 | 1.1/ 1.5 | 2.2 | 3 | 3.7/4 | 5.5 | 7.5 | 7.5 | 11 | 15 |
| | 500 [V] [kW] | - | - | - | 0.25 | 0.37 | 0.55/ 0.75 | 1.1 | 1.5/ 2.2 | 3 | 3.7 | 4/5.5 | 7.5 | 11 | 11 | 15 | 18.5 |
| | 690 [V] [kW] | - | - | - | 0.25 | 0.37/ 0.55 | 0.75/ 1.1 | 1.5 | 2.2/3 | 3.7/4 | 5.5 | 7.5 | 11 | 11 | 15 | 18.5 | 22 |
| Ultimate short-circuit breaking capacity (I _{cu}) | 230 / 240 [V] [kA] | 100 | 100 | 100 | 100 | 100 | 100 | 100 | 100 | 100 | 100 | 100 | 100 | 100 | 100 | 100 | 100 |
| | 400 / 415 [V] [kA] | 100 | 100 | 100 | 100 | 100 | 100 | 100 | 100 | 100 | 100 | 100 | 100 | 100 | 50 | 50 | 50 |
| | 440 / 460[V] [kA] | 100 | 100 | 100 | 100 | 100 | 100 | 100 | 100 | 100 | 100 | 50 | 50 | 50 | 20 | 20 | 20 |
| | 500 [V] [kA] | 100 | 100 | 100 | 100 | 100 | 100 | 100 | 100 | 100 | 100 | 50 | 50 | 42 | 10 | 10 | 10 |
| Rated service short-circuit breaking capacity (I _{cs}) | 230 / 240 [V] [kA] | 100 | 100 | 100 | 100 | 100 | 100 | 100 | 100 | 100 | 100 | 100 | 100 | 100 | 100 | 100 | 100 |
| | 400 / 415 [V] [kA] | 100 | 100 | 100 | 100 | 100 | 100 | 100 | 100 | 100 | 100 | 100 | 100 | 100 | 38 | 38 | 38 |
| | 440 / 460[V] [kA] | 100 | 100 | 100 | 100 | 100 | 100 | 100 | 100 | 100 | 38 | 38 | 38 | 15 | 15 | 15 | 15 |
| | 500 [V] [kA] | 100 | 100 | 100 | 100 | 100 | 100 | 100 | 100 | 100 | 38 | 38 | 32 | 8 | 8 | 8 | 8 |
| Rated service short-circuit breaking capacity of one single pole | 230 / 240 [V] [kA] | 100 | 100 | 100 | 100 | 100 | 100 | 100 | 100 | 100 | 100 | 100 | 100 | 38 | 38 | 38 | 38 |
| | 400 / 415 [V] [kA] | 100 | 100 | 100 | 100 | 100 | 100 | 8 | 8 | 6 | 6 | 6 | 6 | 4 | 4 | 4 | 4 |

. In accordance with UL 508 certification

| Rated operational current - I _e [A] | | 0.16 | 0.25 | 0.4 | 0.63 | 1 | 1.6 | 2.5 | 4 | 6 | 8 | 10 | 13 | 17 | 22 | 26 | 32 |
|--|--------------|------|------|-----|------|-----|------|-------|-----|-------|-----|-------|-------|-----|-------|-------|-------|
| Max. short-circuit current | | | | | | | | | | | | | | | | | |
| | 240 [V] [kA] | 100 | 100 | 100 | 100 | 100 | 100 | 100 | 100 | 100 | 100 | 100 | 100 | 100 | 100 | 100 | 100 |
| | 480 [V] [kA] | 50 | 50 | 50 | 50 | 50 | 50 | 50 | 50 | 50 | 50 | 50 | 50 | 30 | 30 | 30 | 30 |
| | 600 [V] [kA] | 10 | 10 | 10 | 10 | 10 | 10 | 10 | 10 | 10 | 10 | 10 | 10 | 10 | 10 | 10 | 10 |
| Motor load | | | | | | | | | | | | | | | | | |
| 1 Phase | 115 [V] [HP] | - | - | - | - | - | - | - | 1/8 | 1/4 | 1/3 | 1/2 | 1/2 | 1 | 1 1/2 | 2 | 2 |
| | 230 [V] [HP] | - | - | - | - | - | 1/10 | 1/6 | 1/3 | 1/2 | 1 | 1 1/2 | 2 | 3 | 3 | 3 | 5 |
| 3 Phase | 200 [V] [HP] | - | - | - | - | - | - | 1/2 | 3/4 | 1 | 2 | 2 | 3 | 3 | 5 | 7 1/2 | 7 1/2 |
| | 230 [V] [HP] | - | - | - | - | - | - | 1/2 | 3/4 | 1 1/2 | 2 | 3 | 3 | 5 | 7 1/2 | 7 1/2 | 10 |
| | 460 [V] [HP] | - | - | - | - | - | 3/4 | 1 | 2 | 3 | 5 | 5 | 7 1/2 | 10 | 15 | 15 | 20 |
| | 575 [V] [HP] | - | - | - | - | 1/2 | 3/4 | 1 1/2 | 3 | 5 | 5 | 7 1/2 | 10 | 15 | 20 | 20 | 30 |
| Max. Fuse size | [A] | 1 | 1 | 1 | 1 | 3 | 6 | 10 | 15 | 20 | 30 | 40 | 50 | 60 | 80 | 100 | 125 |
| Max. Breaker size | [A] | 15 | 15 | 15 | 15 | 15 | 15 | 15 | 15 | 20 | 30 | 40 | 50 | 60 | 80 | 100 | 125 |

5. GENERAL CHARACTERISTICS (continued)

Breaking capacity: (continued)

. For MPX³ 63H

| Rated operational current - I _e [A] | | | 10 | 13 | 17 | 22 | 26 | 32 | 40 | 50 | 63 |
|--|---------------|------|-------|-----|-------|-----|------|------|------|-----|-----|
| Switching of standard three-phase motors AC-2, AC-3 | 230 / 240 [V] | [kW] | 2,2/3 | 3 | 3,7/4 | 4 | 5,5 | 7,5 | 7,5 | 11 | 15 |
| | 400 / 415 [V] | [kW] | 3,7/4 | 5,5 | 7,5 | 7,5 | 11 | 15 | 18,5 | 22 | 30 |
| | 500 [V] | [kW] | 4/5,5 | 7,5 | 11 | 11 | 15 | 18,5 | 22 | 30 | 37 |
| | 690 [V] | [kW] | 7,5 | 11 | 11 | 15 | 18,5 | 22 | 30 | 45 | 55 |
| Ultimate short-circuit breaking capacity (I _{cu}) | 230 / 240 [V] | [kA] | 100 | 100 | 100 | 100 | 100 | 100 | 100 | 100 | 100 |
| | 400 / 415 [V] | [kA] | 100 | 100 | 50 | 50 | 50 | 50 | 50 | 50 | 50 |
| | 440 / 460[V] | [kA] | 50 | 50 | 50 | 50 | 35 | 35 | 35 | 35 | 35 |
| | 500 [V] | [kA] | 50 | 42 | 12 | 12 | 12 | 10 | 10 | 10 | 10 |
| 690 [V] | [kA] | 6 | 6 | 5 | 5 | 5 | 5 | 5 | 5 | 5 | |
| Rated service short-circuit breaking capacity (I _{cs}) | 230 / 240 [V] | [kA] | 100 | 100 | 100 | 100 | 100 | 100 | 100 | 100 | 100 |
| | 400 / 415 [V] | [kA] | 100 | 100 | 50 | 50 | 50 | 50 | 50 | 50 | 50 |
| | 440 / 460[V] | [kA] | 38 | 38 | 38 | 38 | 27 | 27 | 27 | 27 | 27 |
| | 500 [V] | [kA] | 38 | 32 | 9 | 9 | 9 | 8 | 8 | 8 | 8 |
| 690 [V] | [kA] | 5 | 5 | 5 | 5 | 5 | 5 | 5 | 5 | 5 | |
| Rated service short-circuit breaking capacity of one single pole | 230 / 240 [V] | [kA] | 100 | 100 | 50 | 50 | 50 | 50 | 50 | 50 | 50 |
| | 400 / 415 [V] | [kA] | 5 | 5 | 5 | 5 | 5 | 5 | 5 | 5 | 5 |

. In accordance with UL 508 certification

| Rated operational current - I _e [A] | | | 10 | 13 | 17 | 22 | 26 | 32 | 40 | 50 | 63 |
|--|---------|------|-----|-----|-----|-----|-----|-----|-----|-----|-----|
| Max. short-circuit current | | | | | | | | | | | |
| | 240 [V] | [kA] | 100 | 100 | 100 | 100 | 100 | 100 | 100 | 100 | 100 |
| | 480 [V] | [kA] | 50 | 50 | 50 | 50 | 50 | 50 | 50 | 50 | 50 |
| | 600 [V] | [kA] | 10 | 10 | 10 | 10 | 10 | 10 | 10 | 10 | 10 |
| Motor load | | | | | | | | | | | |
| 1 Phase | 115 [V] | [HP] | 1/2 | 1/2 | 1 | 1½ | 2 | 2 | 3 | 3 | 5 |
| | 230 [V] | [HP] | 1½ | 2 | 3 | 3 | 3 | 5 | 7½ | 10 | 10 |
| 3 Phase | 200 [V] | [HP] | 2 | 3 | 3 | 5 | 7½ | 7½ | 10 | 15 | 20 |
| | 230 [V] | [HP] | 3 | 3 | 5 | 7½ | 7½ | 10 | 10 | 15 | 20 |
| | 460 [V] | [HP] | 5 | 7½ | 10 | 15 | 15 | 20 | 30 | 30 | 40 |
| | 575 [V] | [HP] | 7½ | 10 | 15 | 20 | 20 | 30 | 30 | 40 | 60 |
| Max. Fuse size | | [A] | 40 | 50 | 60 | 80 | 100 | 125 | 150 | 200 | 250 |
| Max. Breaker size | | [A] | 40 | 50 | 60 | 80 | 100 | 125 | 150 | 200 | 250 |

5. GENERAL CHARACTERISTICS (continued)

Breaking capacity: (continued)

. For MPX³ 100H

| Rated operational current - I _e [A] | | | 17 | 22 | 26 | 32 | 40 | 50 | 63 | 75 | 90 | 100 |
|--|---------------|------|-------|-----|------|------|------|-----|-----|-----|-----|-----|
| Switching of standard three-phase motors AC-2, AC-3 | 230 / 240 [V] | [kW] | 3.7/4 | 4 | 5.5 | 7.5 | 7.5 | 11 | 15 | 22 | 30 | 30 |
| | 400 / 415 [V] | [kW] | 7.5 | 7.5 | 11 | 15 | 18.5 | 22 | 30 | 37 | 45 | 45 |
| | 500 [V] | [kW] | 11 | 11 | 15 | 18.5 | 22 | 30 | 37 | 45 | 55 | 63 |
| | 690 [V] | [kW] | 11 | 15 | 18.5 | 22 | 30 | 45 | 55 | 63 | 75 | 90 |
| Ultimate short-circuit breaking capacity (I _{cu}) | 230 / 240 [V] | [kA] | 100 | 100 | 100 | 100 | 100 | 100 | 100 | 100 | 100 | 100 |
| | 400 / 415 [V] | [kA] | 100 | 100 | 100 | 100 | 100 | 100 | 100 | 75 | 75 | 75 |
| | 440 / 460[V] | [kA] | 50 | 50 | 50 | 50 | 50 | 50 | 50 | 50 | 50 | 50 |
| | 500 [V] | [kA] | 35 | 35 | 35 | 25 | 20 | 15 | 15 | 12 | 12 | 12 |
| | 690 [V] | [kA] | 12 | 12 | 12 | 12 | 12 | 10 | 8 | 6 | 6 | 6 |
| Rated service short-circuit breaking capacity (I _{cs}) | 230 / 240 [V] | [kA] | 100 | 100 | 100 | 100 | 100 | 100 | 100 | 100 | 100 | 100 |
| | 400 / 415 [V] | [kA] | 100 | 50 | 50 | 50 | 50 | 50 | 50 | 50 | 50 | 50 |
| | 440 / 460[V] | [kA] | 38 | 38 | 38 | 38 | 38 | 38 | 38 | 38 | 38 | 38 |
| | 500 [V] | [kA] | 27 | 27 | 27 | 19 | 15 | 11 | 11 | 9 | 9 | 9 |
| | 690 [V] | [kA] | 9 | 9 | 9 | 9 | 9 | 8 | 6 | 6 | 6 | 6 |
| Rated service short-circuit breaking capacity of one single pole | 230 / 240 [V] | [kA] | 100 | 50 | 50 | 50 | 50 | 50 | 50 | 50 | 50 | 50 |
| | 400 / 415 [V] | [kA] | 9 | 9 | 9 | 9 | 9 | 8 | 6 | 6 | 6 | 6 |

. In accordance with UL 508 certification

| Rated operational current - I _e [A] | | | 17 | 22 | 26 | 32 | 40 | 50 | 63 | 75 | 90 | 100 |
|--|---------|------|-----|-----|-----|-----|-----|-----|-----|-----|-----|-----|
| Max. short-circuit current | | | | | | | | | | | | |
| | 240 [V] | [kA] | 100 | 100 | 100 | 100 | 100 | 100 | 100 | 100 | 100 | 100 |
| | 480 [V] | [kA] | 50 | 50 | 50 | 50 | 50 | 50 | 50 | 50 | 50 | 50 |
| | 600 [V] | [kA] | 10 | 10 | 10 | 10 | 10 | 10 | 10 | 10 | 10 | 10 |
| Motor load | | | | | | | | | | | | |
| 1 Phase | 115 [V] | [HP] | 1 | 1½ | 2 | 2 | 3 | 3 | 5 | 5 | 7½ | 10 |
| | 230 [V] | [HP] | 3 | 3 | 3 | 5 | 7½ | 10 | 10 | 15 | 20 | 20 |
| 3 Phase | 200 [V] | [HP] | 3 | 5 | 7½ | 7½ | 10 | 15 | 20 | 20 | 25 | 30 |
| | 230 [V] | [HP] | 5 | 7½ | 7½ | 10 | 10 | 15 | 20 | 25 | 30 | 30 |
| | 460 [V] | [HP] | 10 | 15 | 15 | 20 | 30 | 30 | 40 | 50 | 60 | 75 |
| | 575 [V] | [HP] | 15 | 20 | 20 | 30 | 30 | 40 | 60 | 60 | 75 | 100 |
| Max. Fuse size | | [A] | 60 | 80 | 100 | 125 | 150 | 200 | 250 | 300 | 350 | 400 |
| Max. Breaker size | | [A] | 60 | 80 | 100 | 125 | 150 | 200 | 250 | 300 | 350 | 400 |

5. GENERAL CHARACTERISTICS *(continued)*

Coordination: Type 2

. According to IEC 60947-4-1

- Short circuit current : I_q = 50 [kA]
- Voltage : 230/240 [V~]
- Frequency : 50/60 [Hz]

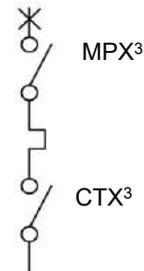

| Motor | | MPX ³ | | CTX ³ |
|-------|------|-----------------------|---------------|-------------------------------|
| [kW] | [A] | Type | Rating In [A] | Type |
| 0.37 | 1.8 | MPX ³ 32H | 2.5 | CTX ³ 22 - 9 [A] |
| 0.55 | 2.75 | MPX ³ 32H | 4 | CTX ³ 40 - 32 [A] |
| 0.75 | 3.5 | MPX ³ 32H | 4 | |
| 1.1 | 4.4 | MPX ³ 63H | 10 | CTX ³ 40 - 40 [A] |
| 1.5 | 6.1 | MPX ³ 63H | 10 | |
| 2.2 | 8.7 | MPX ³ 63H | 13 | |
| 3 | 11.5 | MPX ³ 63H | 13 | |
| 3.7 | 13.5 | MPX ³ 63H | 18 | |
| 4 | 14.5 | MPX ³ 63H | 18 | |
| 5.5 | 20 | MPX ³ 63H | 22 | |
| 7.5 | 27 | MPX ³ 63H | 32 | |
| 9 | 32 | MPX ³ 100H | 32 | CTX ³ 100 - 85 [A] |
| 10 | 35 | MPX ³ 100H | 40 | |
| 11 | 39 | MPX ³ 100H | 40 | |
| 15 | 52 | MPX ³ 100H | 63 | |
| 18.5 | 64 | MPX ³ 100H | 75 | |
| 22 | 75 | MPX ³ 100H | 75 | |
| 25 | 85 | MPX ³ 100H | 90 | |

5. GENERAL CHARACTERISTICS *(continued)*

Coordination: Type 2 *(continued)*

. According to IEC 60947-4-1

- Short circuit current : I_q = 50 [kA]
- Voltage : 400/415 [V~]
- Frequency : 50/60 [Hz]

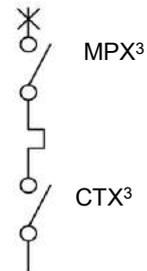

| Motor | | MPX ³ | | CTX ³ |
|-------|------|-----------------------|---------------|-------------------------------|
| [kW] | [A] | Type | Rating In [A] | Type |
| 0.37 | 1.1 | MPX ³ 32S | 1.6 | CTX ³ 22 - 9 [A] |
| 0.55 | 1.5 | MPX ³ 32S | 1.6 | |
| 0.75 | 1.9 | MPX ³ 32S | 2.5 | CTX ³ 22 - 12 [A] |
| 1.1 | 2.7 | MPX ³ 32S | 4 | CTX ³ 22 - 18 [A] |
| 1.5 | 3.6 | MPX ³ 32S | 4 | |
| 2.2 | 5.2 | MPX ³ 32S | 6 | |
| 3 | 6.8 | MPX ³ 32S | 8 | |
| 4 | 9 | MPX ³ 32S | 10 | |
| 5.5 | 11.5 | MPX ³ 32H | 13 | CTX ³ 22 - 22 [A] |
| 7.5 | 15.5 | MPX ³ 32H | 17 | |
| 10 | 20 | MPX ³ 32H | 22 | CTX ³ 40 - 32 [A] |
| 11 | 22 | MPX ³ 32H | 26 | |
| 15 | 29 | MPX ³ 32H | 32 | |
| 18.5 | 35 | MPX ³ 63H | 40 | CTX ³ 40 - 40 [A] |
| 22 | 41 | MPX ³ 63H | 50 | CTX ³ 65 - 50 [A] |
| 30 | 55 | MPX ³ 63H | 63 | CTX ³ 65 - 65 [A] |
| 37 | 67 | MPX ³ 100H | 75 | CTX ³ 100 - 75 [A] |
| 45 | 80 | MPX ³ 100H | 100 | CTX ³ 100 - 85 [A] |

5. GENERAL CHARACTERISTICS *(continued)*

Coordination: Type 2 *(continued)*

. According to IEC 60947-4-1

- Short circuit current : I_q = 50 [kA]
- Voltage : 440 [V~]
- Frequency : 50/60 [Hz]

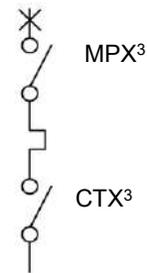

| Motor | | MPX ³ | | CTX ³ |
|-------|------|-----------------------|---------------|-------------------------------|
| [kW] | [A] | Type | Rating In [A] | Type |
| 0.37 | 0.99 | MPX ³ 32S | 1 | CTX ³ 22 - 9 [A] |
| 0.55 | 1.36 | MPX ³ 32S | 1.6 | |
| 0.75 | 1.68 | MPX ³ 32S | 2.5 | |
| 1.1 | 2.37 | MPX ³ 32S | 2.5 | |
| 1.5 | 3.06 | MPX ³ 32S | 4 | CTX ³ 22 - 18 [A] |
| 2.2 | 4.42 | MPX ³ 32H | 6 | CTX ³ 22 - 22 [A] |
| 3 | 5.57 | MPX ³ 32H | 6 | |
| 3.7 | 7.1 | MPX ³ 32H | 8 | CTX ³ 40 - 32 [A] |
| 4 | 7.9 | MPX ³ 32H | 8 | |
| 5.5 | 10.4 | MPX ³ 32H | 13 | |
| 9 | 16.9 | MPX ³ 63H | 17 | |
| 11 | 20.1 | MPX ³ 63H | 22 | CTX ³ 40 - 40 [A] |
| 15 | 26.5 | MPX ³ 63H | 32 | |
| 18.5 | 32.8 | MPX ³ 63H | 40 | CTX ³ 65 - 50 [A] |
| 22 | 39 | MPX ³ 63H | 40 | |
| 25 | 45.3 | MPX ³ 63H | 50 | |
| 30 | 51.5 | MPX ³ 100H | 63 | CTX ³ 65 - 65 [A] |
| 33 | 58 | MPX ³ 100H | 63 | |
| 37 | 64 | MPX ³ 100H | 63 | |
| 40 | 67 | MPX ³ 100H | 75 | CTX ³ 100 - 85 [A] |
| 45 | 76 | MPX ³ 100H | 75 | |

5. GENERAL CHARACTERISTICS (continued)

IE3 motors use

| Type | Rated Current(A) | Instantaneous trip current (A) | Current setting range (A) | | | Instantaneous trip current value (times) | | |
|----------------------|------------------|--------------------------------|---------------------------|------|------|--|-----|-----|
| | | | Min | Mid | Max | Min | Mid | Max |
| MPX ³ 32 | 0.16A | 2,08 | 0,1 | 0,13 | 0,16 | 21 | 16 | 13 |
| | 0.25A | 3,25 | 0,16 | 0,2 | 0,25 | 20 | 16 | 13 |
| | 0.4A | 5,2 | 0,25 | 0,33 | 0,4 | 21 | 16 | 13 |
| | 0.63A | 8,19 | 0,4 | 0,52 | 0,63 | 20 | 16 | 13 |
| | 1A | 13 | 0,63 | 0,81 | 1 | 21 | 16 | 13 |
| | 1.6A | 20,8 | 1 | 1,3 | 1,6 | 21 | 16 | 13 |
| | 2.5A | 32,5 | 1,6 | 2,1 | 2,5 | 20 | 15 | 13 |
| | 4A | 52 | 2,5 | 3,3 | 4 | 21 | 16 | 13 |
| | 6A | 78 | 4 | 5 | 6 | 20 | 16 | 13 |
| | 8A | 104 | 5 | 6,5 | 8 | 21 | 16 | 13 |
| | 10A | 130 | 6 | 8 | 10 | 22 | 16 | 13 |
| | 13A | 169 | 9 | 11 | 13 | 19 | 15 | 13 |
| | 17A | 221 | 11 | 14 | 17 | 20 | 16 | 13 |
| | 22A | 286 | 14 | 18 | 22 | 20 | 16 | 13 |
| | 26A | 338 | 18 | 22 | 26 | 19 | 15 | 13 |
| 32A | 416 | 22 | 27 | 32 | 19 | 15 | 13 | |
| MPX ³ 63 | 10A | 130 | 6 | 8 | 10 | 22 | 16 | 13 |
| | 13A | 169 | 9 | 11 | 13 | 19 | 15 | 13 |
| | 17A | 221 | 11 | 14 | 17 | 20 | 16 | 13 |
| | 22A | 286 | 14 | 17 | 22 | 20 | 17 | 13 |
| | 26A | 338 | 18 | 22 | 26 | 19 | 15 | 13 |
| | 32A | 416 | 22 | 27 | 32 | 19 | 15 | 13 |
| | 40A | 520 | 28 | 34 | 40 | 19 | 15 | 13 |
| | 50A | 650 | 34 | 42 | 50 | 19 | 15 | 13 |
| | 63A | 819 | 45 | 54 | 63 | 18 | 15 | 13 |
| MPX ³ 100 | 17A | 221 | 11 | 14 | 17 | 20 | 16 | 13 |
| | 22A | 286 | 14 | 18 | 22 | 20 | 16 | 13 |
| | 26A | 338 | 18 | 22 | 26 | 19 | 15 | 13 |
| | 32A | 416 | 22 | 27 | 32 | 19 | 15 | 13 |
| | 40A | 520 | 28 | 34 | 40 | 19 | 15 | 13 |
| | 50A | 650 | 34 | 42 | 50 | 19 | 15 | 13 |
| | 63A | 819 | 45 | 54 | 63 | 18 | 15 | 13 |
| | 75A | 975 | 55 | 65 | 75 | 18 | 15 | 13 |
| | 90A | 1170 | 70 | 80 | 90 | 17 | 15 | 13 |
| | 100A | 1300 | 80 | 90 | 100 | 16 | 14 | 13 |

6. CONFORMITIES AND APPROVALS

Compliance to standards:

- . Standard reference: IEC/EN 60 947-2 (Breaker).
- . Standard reference: IEC/EN 60 947-4 (Motor starter).
- . Certificate of compliance with UL 508 standard.

7. CURVES

Time / Current tripping curve:

. For MPX³ 32S / MPX³ 32H / MPX³ 32MA

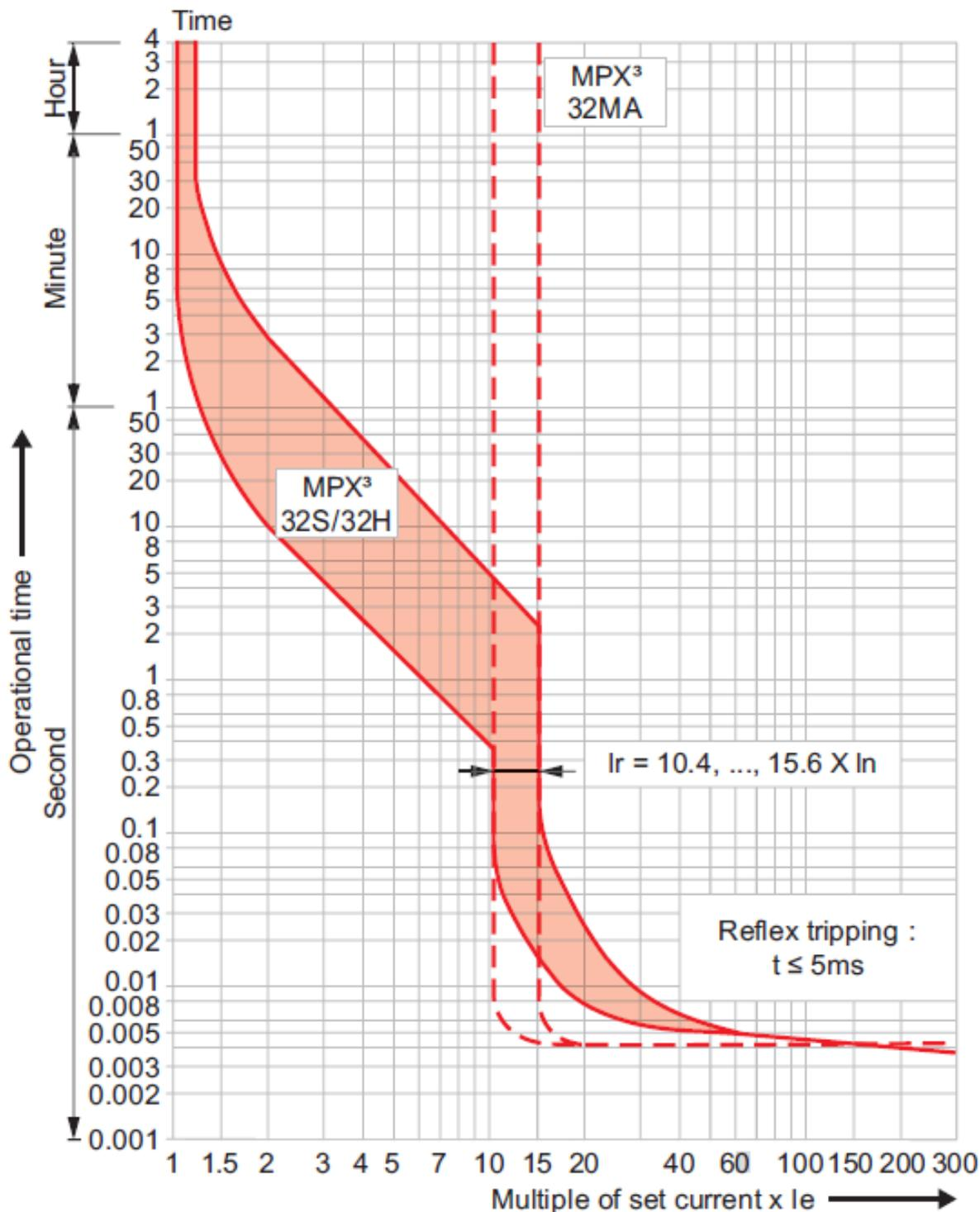

7. CURVES (continued)

Time / Current tripping curve:
. For MPX³ 63H / MPX³ 100H

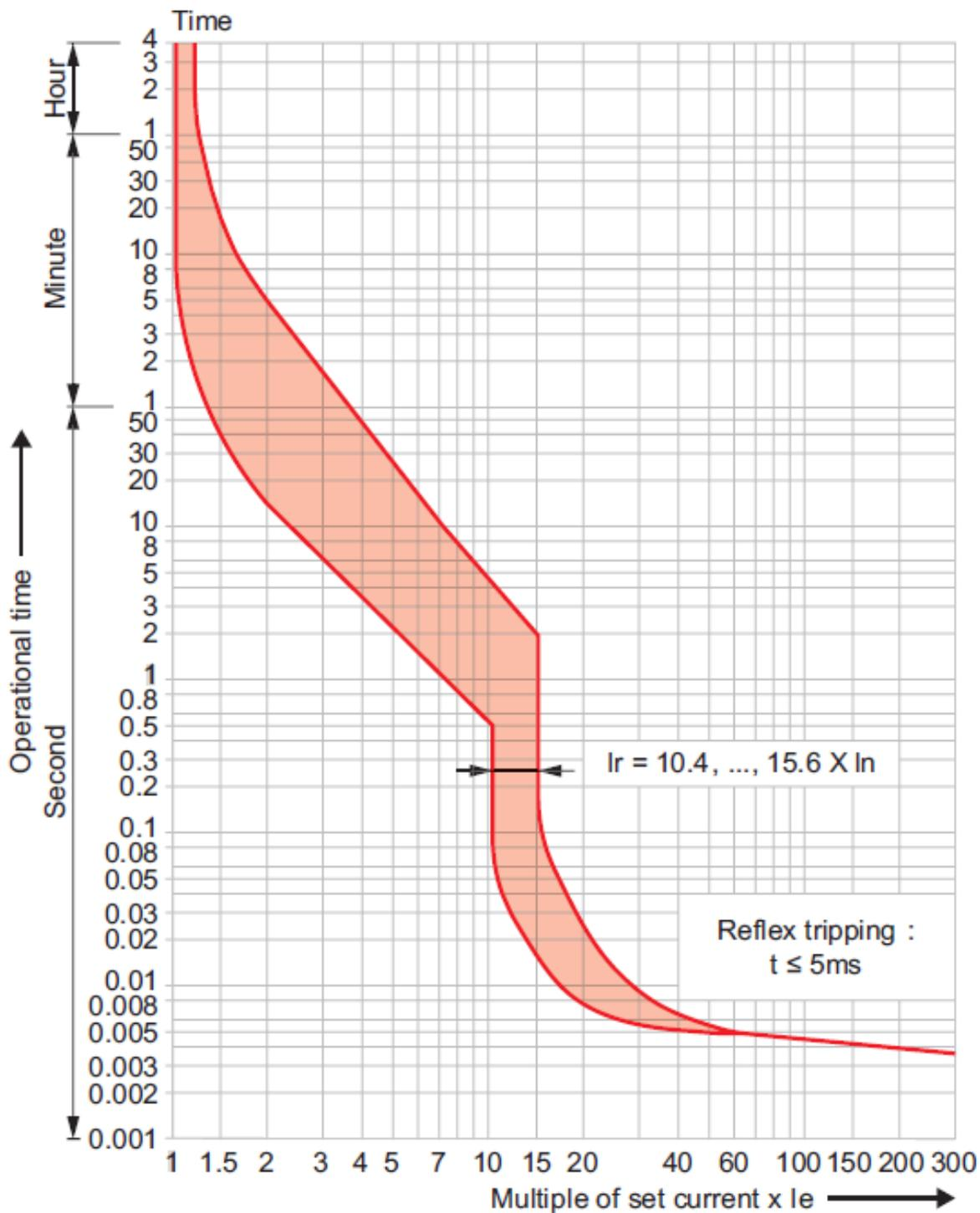

7. CURVES (continued)

Thermal limit on short circuit (U_e = 415V) :
. For MPX³ 32S

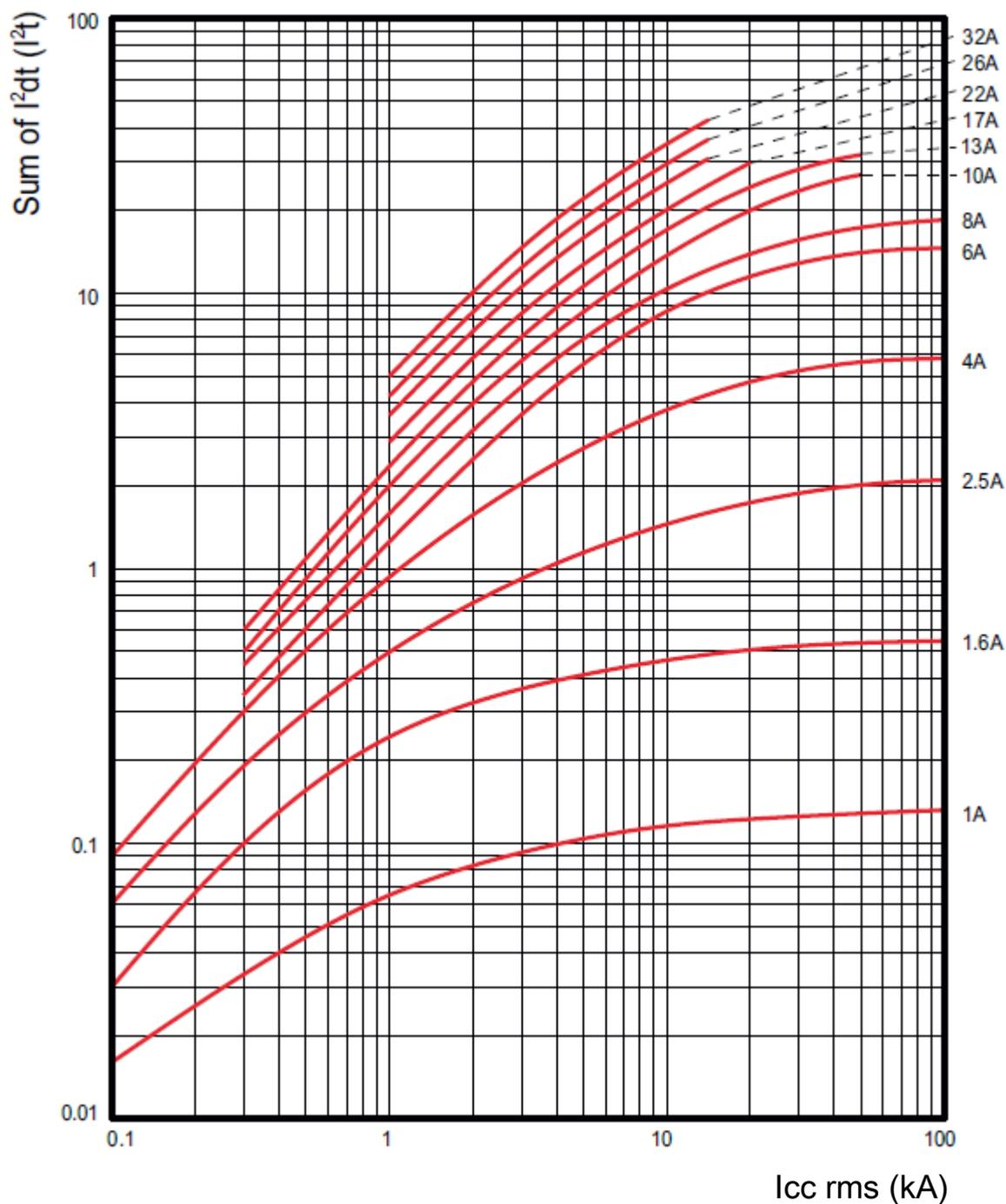

. I_{cc} = Square value of symmetric component of the short circuit current (kA).
. I²t = Thermal energy limited (kA²s).

7. CURVES (continued)

Thermal limit on short circuit (Ue = 415V) :

. For MPX³ 32H / MPX³ 32MA

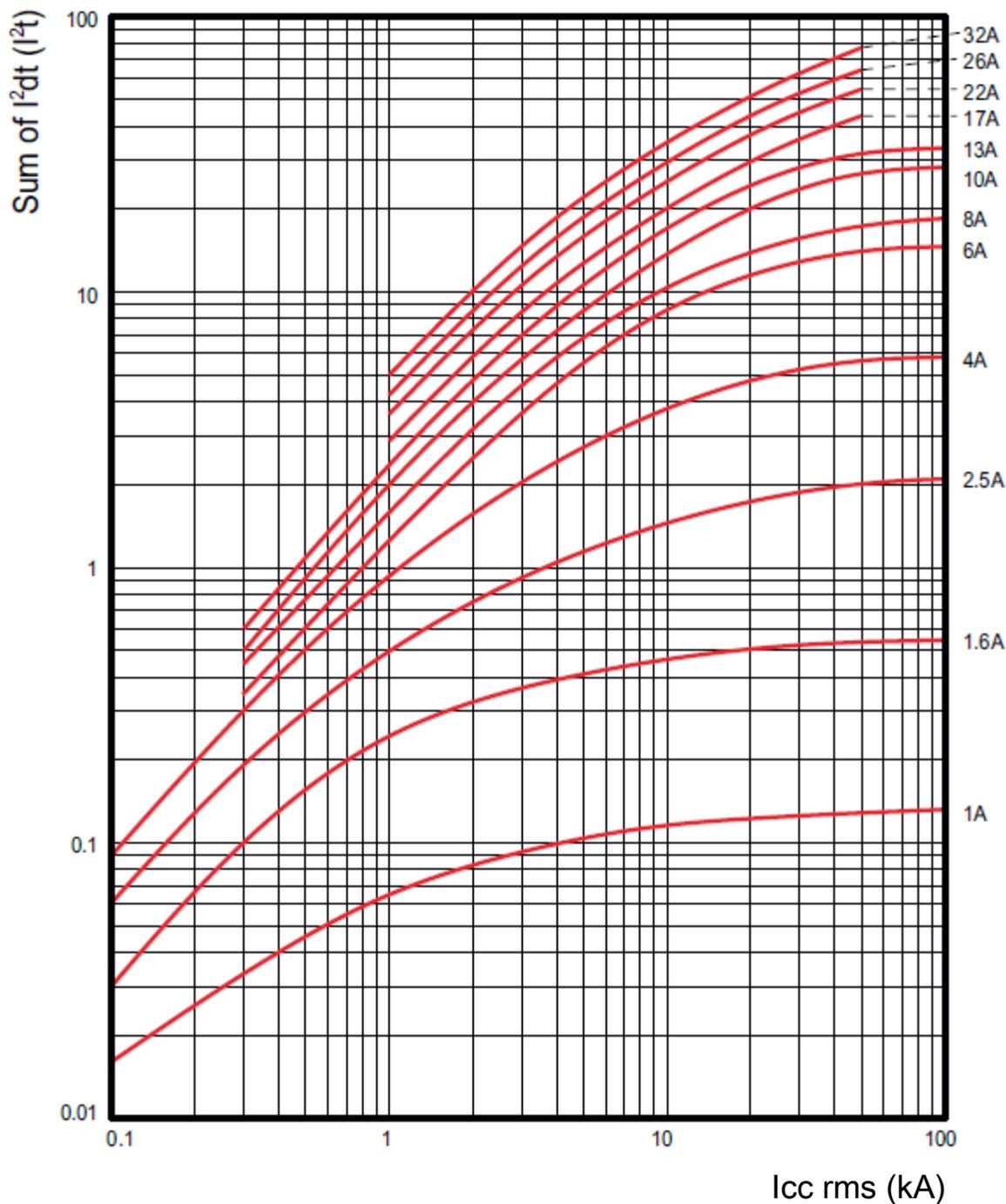

. Icc = Square value of symmetric component of the short circuit current (kA).

. I²t = Thermal energy limited (kA²s).

7. CURVES (continued)

Thermal limit on short circuit (U_e = 415V) :
. For MPX³ 63H

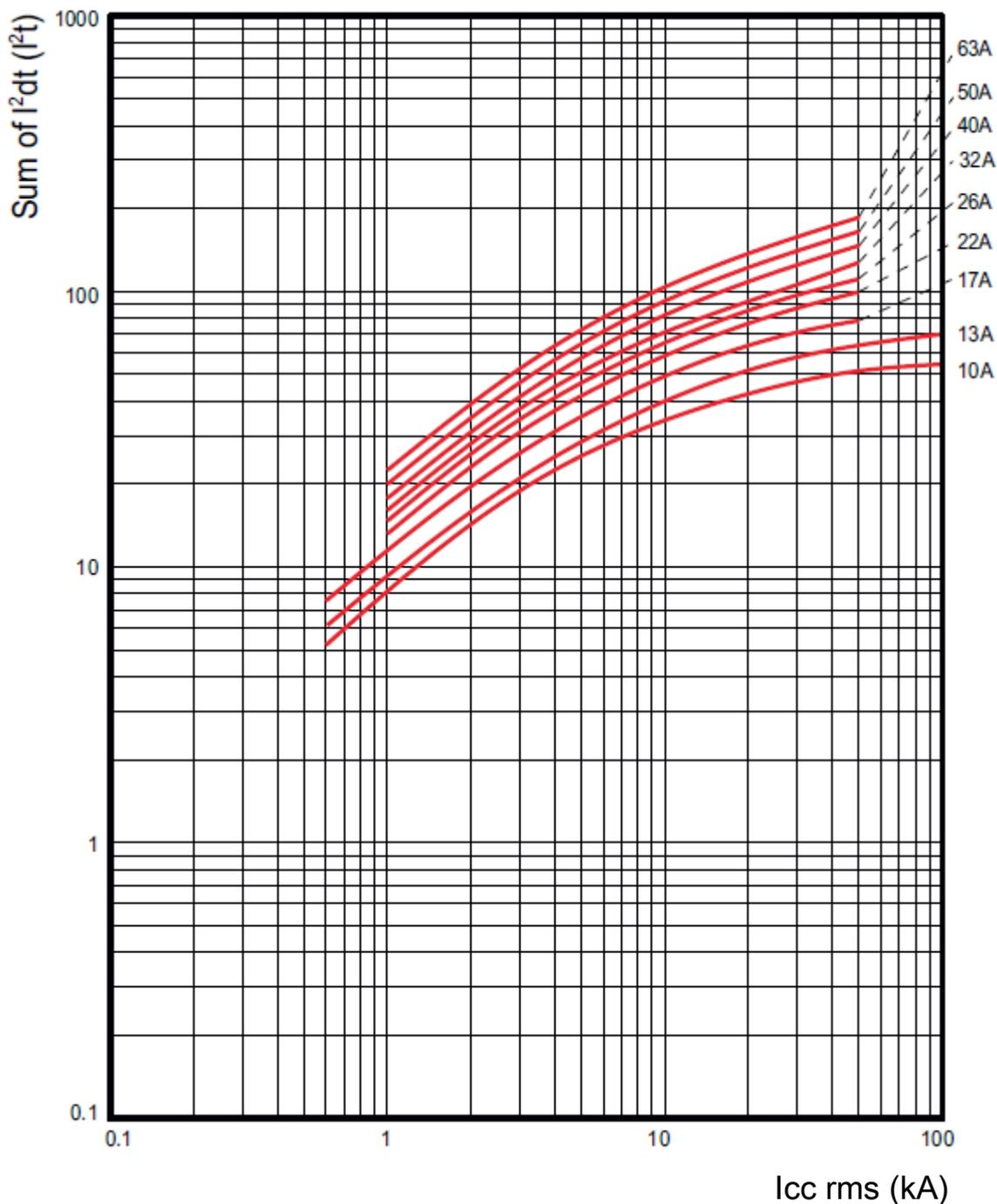

. I_{cc} = Square value of symmetric component of the short circuit current (kA).
. I²t = Thermal energy limited (kA²s).

7. CURVES (continued)

Thermal limit on short circuit (U_e = 415V) :
. For MPX³ 100H

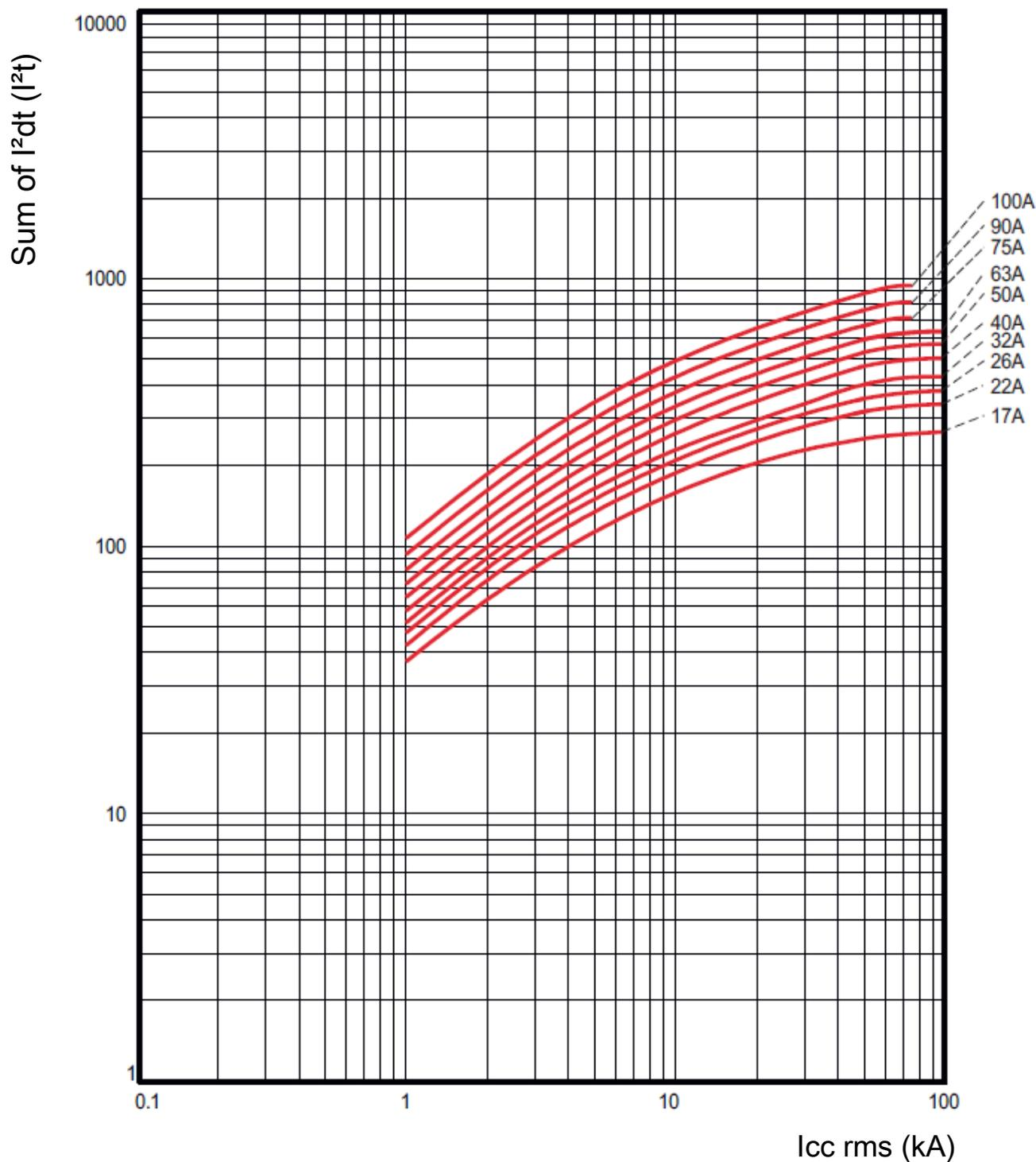

. I_{cc} = Square value of symmetric component of the short circuit current (kA).
. I²t = Thermal energy limited (kA²s).

7. CURVES (continued)

Peak current in kA ($U_e = 415V$) :

. For MPX³ 32S

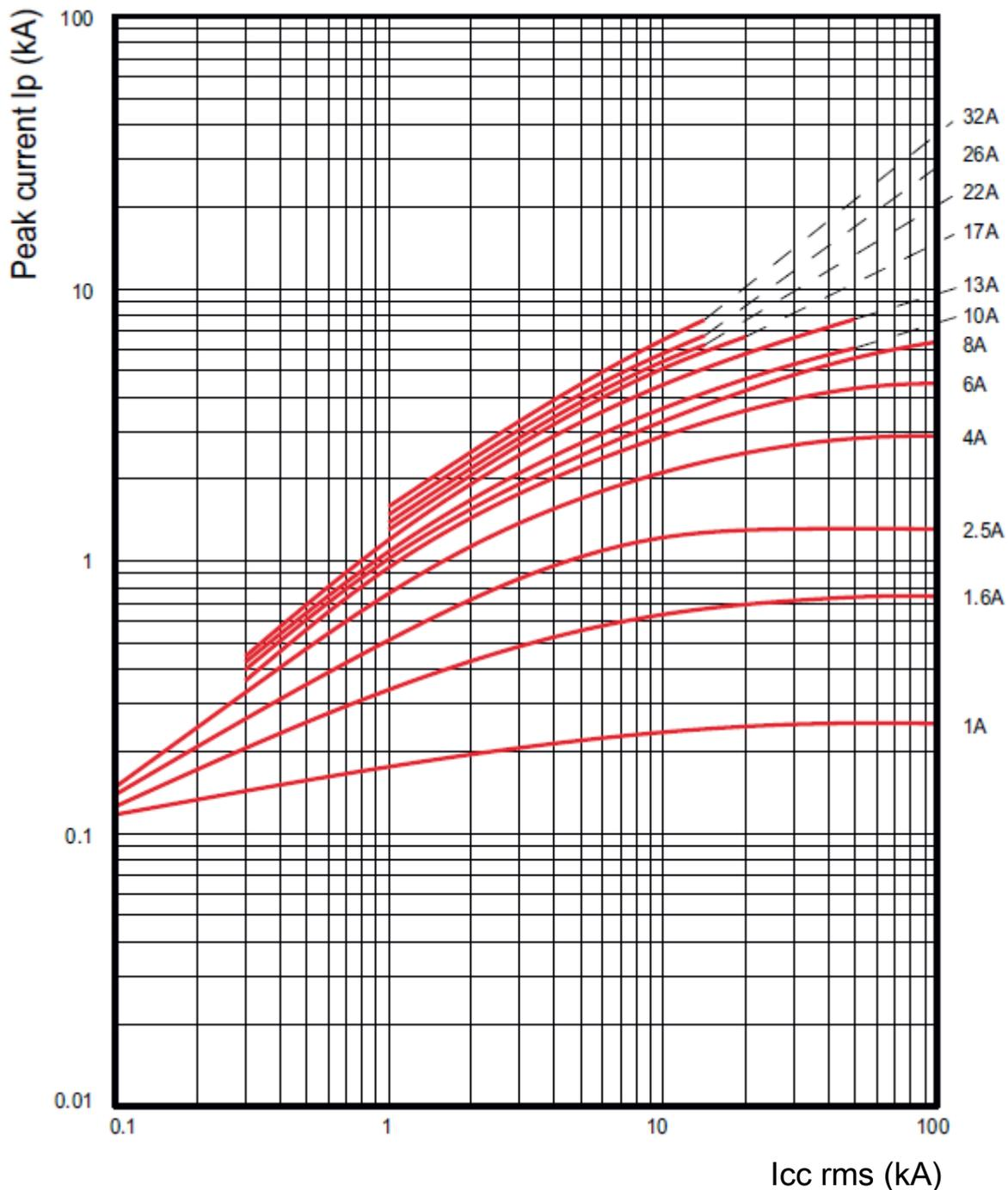

. I_{cc} = Square value of symmetric component of the short circuit current (kA).

. I_p = Peak current (kA).

7. CURVES (continued)

Peak current in kA ($U_e = 415V$) :

. For MPX³ 32H / MPX³ 32MA

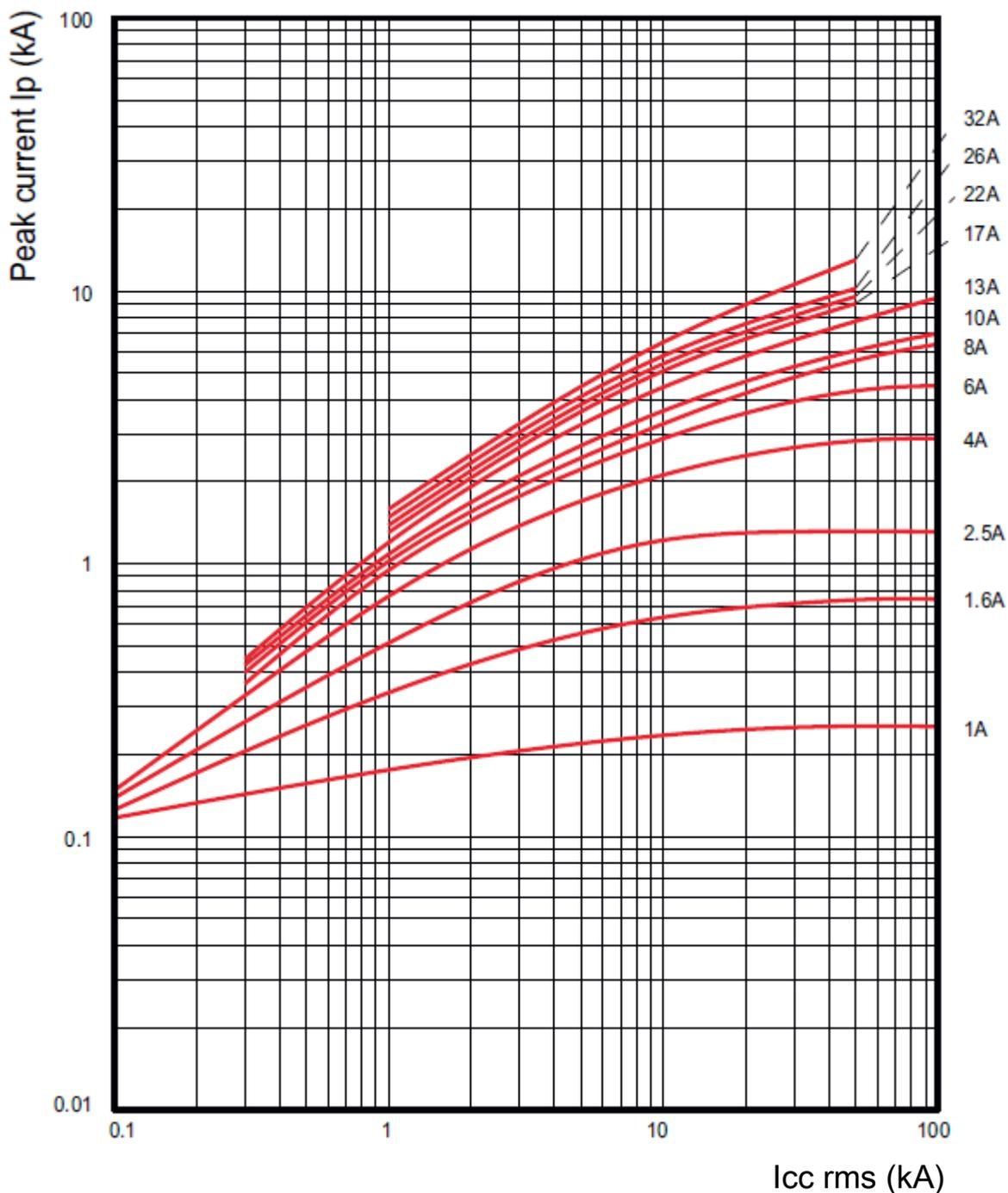

. I_{cc} = Square value of symmetric component of the short circuit current (kA).

. I_p = Peak current (kA).

7. CURVES (continued)

Peak current in kA (U_e = 415V) :

. For MPX³ 63H

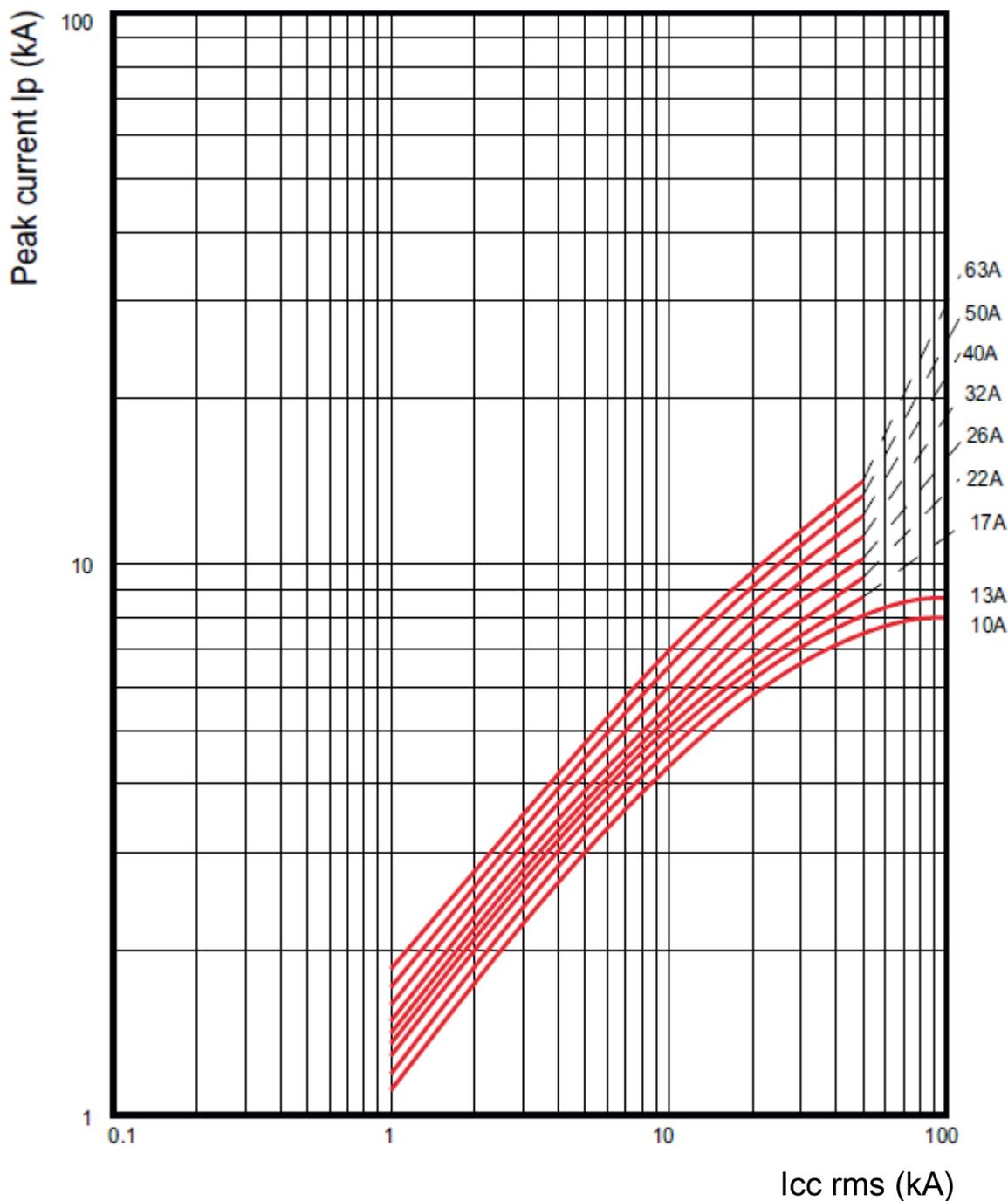

. I_{cc} = Square value of symmetric component of the short circuit current (kA).

. I_p = Peak current (kA).

7. CURVES (continued)

Peak current in kA ($U_e = 415V$) :

. For MPX³ 100H

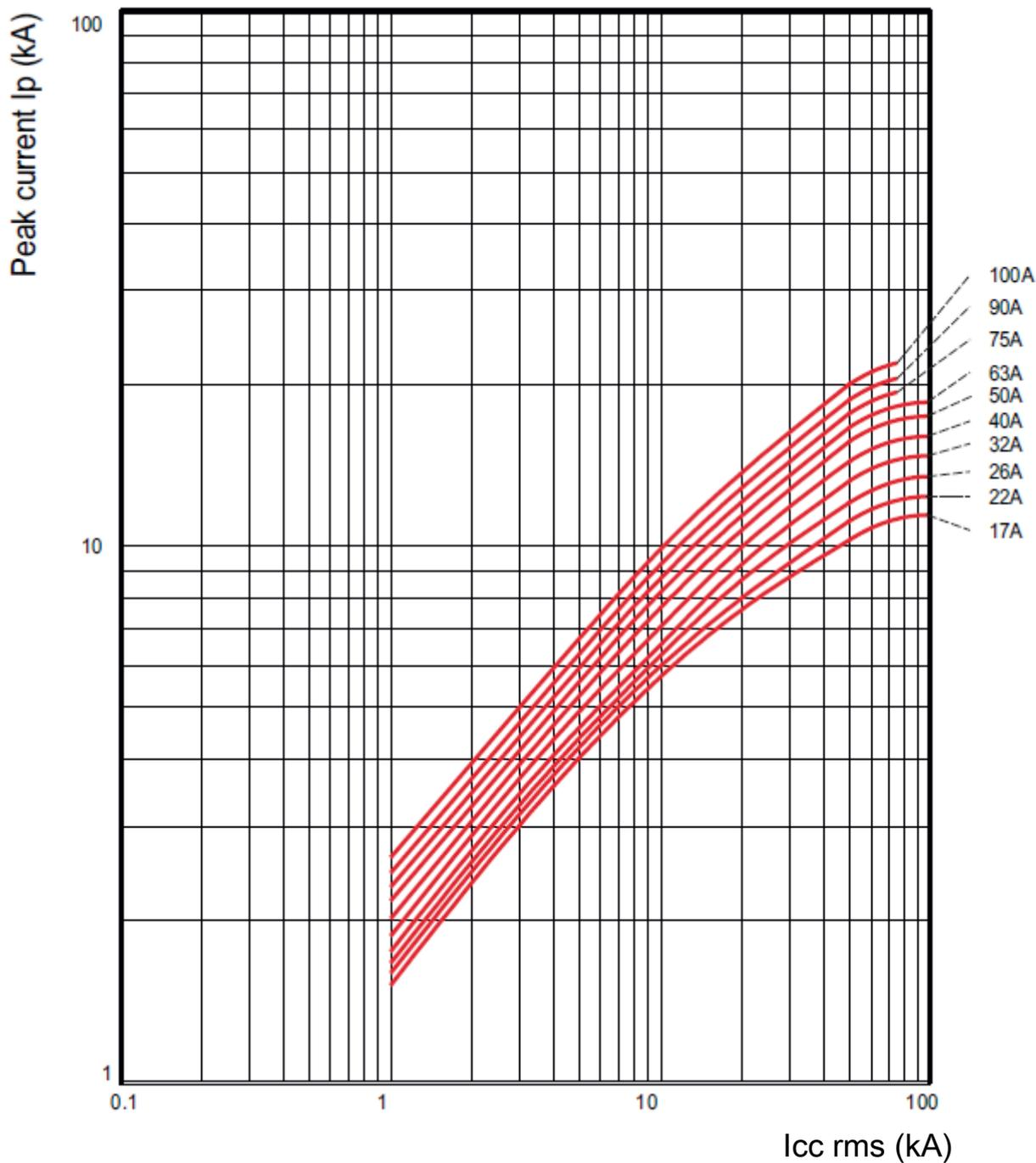

. I_{cc} = Square value of symmetric component of the short circuit current (kA).

. I_p = Peak current (kA).

8. AUXILIARIES AND ACCESSORIES

Auxiliaries: (maximum 2 auxiliary switches per MPX³)

- . Auxiliary switch: (front mounting)
 - Auxiliary switch NO + NC (cat n° 4 174 03).

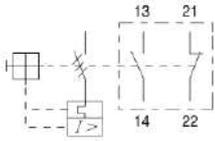

- Auxiliary switch 2NO (cat n° 4 174 04).

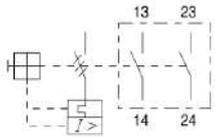

- Auxiliary switch 2NC (cat n° 4 174 05).

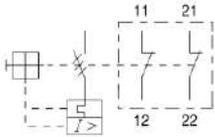

- . Auxiliary switch: (side mounting on the left)
 - Auxiliary switch NO + NC (cat n° 4 174 00).

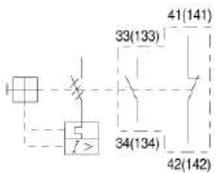

- Auxiliary switch 2NO (cat n° 4 174 01).

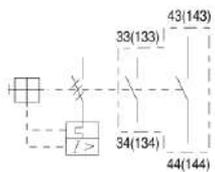

- Auxiliary switch 2NC (cat n° 4 174 02).

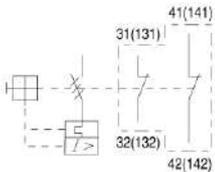

- . Any trip alarm switch: (side mounting on the left)
 - Any trip alarm switch NO + NC (cat n° 4 174 06).
 - Any trip alarm switch NO + NC 63/100A (cat n° 4 174 08).

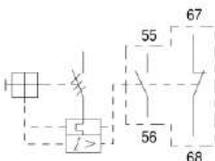

8. AUXILIARIES AND ACCESSORIES (continued)

Auxiliaries: (continued)

- . Magnetic trip alarm switch: (side mounting on the left)
 - Magnetic trip alarm switch NO + NC (cat n° 4 174 07).

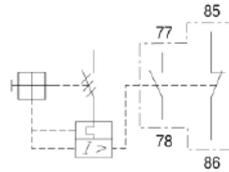

- . Shunt release: (side mounting on the right)
 - Shunt release 24V AC (cat n° 4 174 10).
 - Shunt release 110V AC (cat n° 4 174 11).
 - Shunt release 230V AC (cat n° 4 174 12).
 - Shunt release 400V AC (cat n° 4 174 13).

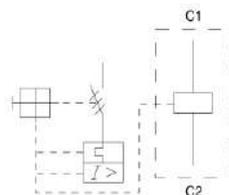

- . Undervoltage release: (side mounting on the right)
 - Undervoltage release 24V AC (cat n° 4 174 20).
 - Undervoltage release 110V AC (cat n° 4 174 21).
 - Undervoltage release 230V AC (cat n° 4 174 22).
 - Undervoltage release 400V AC (cat n° 4 174 23).

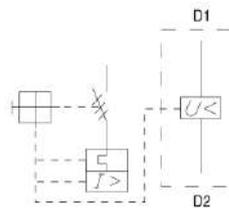

- . Undervoltage release with switch: (side mounting on the right)
 - Undervoltage release with switch 2NO 24V AC. (cat n° 4 174 30)
 - Undervoltage release with switch 2NO 110V AC. (cat n° 4 174 31)
 - Undervoltage release with switch 2NO 230V AC. (cat n° 4 174 32)
 - Undervoltage release with switch 2NO 400V AC. (cat n° 4 174 33)

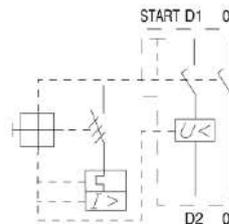

8. AUXILIARIES AND ACCESSORIES (continued)

Auxiliaries: (continued)

. Possible combinations of auxiliaries:

| Auxiliaries | | | MPX ³ 32S | | MPX ³ 32H / MA | | MPX ³ 63H | | | MPX ³ 100H | |
|------------------------------------|----------------|----------|----------------------|------|---------------------------|------|----------------------|------------------|------------------|-----------------------|------------------|
| Auxiliary contacts | Front mounting | Max. No. | 0 | 1 or | 0 | 1 or | 0 | 1 or | 1 | 0 | 1 or |
| | Side mounting | Max. No. | 2 | 1 | 2 | 1 | 2 | 1 | 0 | 2 | 1 |
| Fault signal contact | | Max. No. | 0 | 1 | 0 | 1 | 0 | 1 ⁽¹⁾ | 1 ⁽²⁾ | 0 | 1 ⁽²⁾ |
| Shunt trip or undervoltage release | | Max. No. | 1 | 1 | 1 | 1 | 1 | 1 | 1 | 1 | 1 |

(1) : cat n° 4 174 07

(2) : cat n° 4 174 08

General characteristics auxiliaries:

| | | | Auxiliary contacts for front mounting | | Auxiliary contacts for left side mounting | | Alarm switch for left side mounting | |
|---|--|--|---------------------------------------|--|---|--|---|--|
| Rated thermal current / I _n | | | | | | | | |
| at 40°C ambient temperature | | | [A] 5 | | 10 | | 10 | |
| at 60°C ambient temperature | | | [A] 3 | | 6 | | 6 | |
| Contact class coordination according to NEMA (UL/CSA-Standards) | | | AC A600 | | A600 | | A600 | |
| | | | DC Q300 | | Q300 | | Q300 | |
| Back-up fuses gG, gL | | | [A] 16 | | 16 | | 16 | |
| Rated supply current | | | [V] - 240 | | 24 240 | | 24 240 | |
| AC-15: | | | [A] - 3 | | 6 4 | | 6 4 | |
| DC-13: | | | [V] 24 220 | | 24 220 | | 24 220 | |
| | | | [A] 1 0.1 | | 2 0.25 | | 2 0.25 | |
| Weight (g) | | | 18 | | 30 | | 40 | |
| Terminal parts | | | | | | |  | |
| Wire | | | | | | | Pozidriv size 2 | |
| Single-core 1 conductor | | | [mm] / [AWG] 0.5...2.5 / 20...14 | | 0.5...2.5 / 20...14 | | 0.5...2.5 / 20...14 | |
| 2 conductor | | | [mm] / [AWG] - | | - | | 0.5...2.5 / 20...14 | |
| Stranded 1 conductor | | | [mm] / [AWG] 0.5...4 / 20...10 | | 0.5...4 / 20...10 | | 0.5...4 / 20...10 | |
| 2 conductor | | | [mm] / [AWG] 0.75...2.5 / 18...14 | | 0.75...2.5 / 18...14 | | 0.75...2.5 / 18...14 | |
| Tightening torque | | | [Nm] / [lb-in] 0.8...1.2 / 7...10 | | 0.8...1.2 / 7...10 | | 0.8...1.2 / 7...10 | |

| | | | Undervoltage release for right side mounting | | Undervoltage release with 2 auxiliary contacts for right side mounting | | Shunt release for right side mounting | |
|-------------------------|--|--|--|--|--|--|---|--|
| Actuating voltage | | | | | | | | |
| Pull-in | | | 0.7...1.1× U _s | | 0.85...1.1× U _s | | 0.85...1.1× U _s | |
| Drop-out | | | | | 0.7...0.35× U _s | | 0.7...0.35× U _s | |
| Rated control voltage | | | | | | | | |
| min.: | | | 24V 50Hz / 28V 60Hz | | 24V 50Hz / 28V 60Hz | | 24V 50Hz / 28V 60Hz | |
| max.: | | | 415-440V 50Hz / 460-480V 60Hz | | 415-440V 50Hz / 460-480V 60Hz | | 415-440V 50Hz / 460-480V 60Hz | |
| Coil rating | | | | | | | | |
| Pull-in | | | 8.5VA, 6W | | 8.5VA, 6W | | 8.5VA, 6W | |
| Hold | | | 3VA, 1.2W | | 3VA, 1.2W | | 3VA, 1.2W | |
| Opening time (ms) | | | - | | 20 | | 20 | |
| Weight (g) | | | 18 | | 30 | | 40 | |
| Terminal parts | | | | | | |  | |
| Wire | | | | | | | Pozidriv size 2 | |
| Single-core 1 conductor | | | [mm] / [AWG] 0.5...2.5 / 20...14 | | 0.5...2.5 / 20...14 | | 0.5...2.5 / 20...14 | |
| 2 conductor | | | [mm] / [AWG] - | | - | | 0.5...2.5 / 20...14 | |
| Stranded 1 conductor | | | [mm] / [AWG] 0.5...4 / 20...10 | | 0.5...4 / 20...10 | | 0.5...4 / 20...10 | |
| 2 conductor | | | [mm] / [AWG] 0.75...2.5 / 18...14 | | 0.75...2.5 / 18...14 | | 0.75...2.5 / 18...14 | |
| Tightening torque | | | [Nm] / [lb-in] 0.8...1.2 / 7...10 | | 0.8...1.2 / 7...10 | | 0.8...1.2 / 7...10 | |

8. AUXILIARIES AND ACCESSORIES (continued)

Auxiliaries: (continued)

. Direct connector and Mounting unit

| Type | | Combined devices | | |
|------------------|---|--------------------------|-----------------------------------|--------------------------|
| Direct connector | Mounting Unit | MPX ³ | CTX ³ | |
| 4 174 40 | Mounting Unit MPX ³ 32S / 32H / 32MA 4 174 60 | MPX ³ 32S | CTX ³ mini AC | |
| 4 174 41 | | | CTX ³ mini DC | |
| 4 174 48 | | | CTX ³ 22 AC | |
| 4 174 49 | | | CTX ³ 22 DC | |
| 4 174 52 | | | CTX ³ 40 AC | |
| 4 174 53 | | | CTX ³ 40 DC | |
| 4 174 42 | | | MPX ³ 32H / 32MA | CTX ³ mini AC |
| 4 174 43 | | | | CTX ³ mini DC |
| 4 174 50 | | | | CTX ³ 22 AC |
| 4 174 51 | | | | CTX ³ 22 DC |
| 4 174 54 | CTX ³ 40 AC | | | |
| 4 174 55 | CTX ³ 40 DC | | | |
| 4 174 56 | Mounting Unit MPX ³ 63H 4 174 61 | MPX ³ 63H | CTX ³ 65 AC | |
| 4 174 57 | | | CTX ³ 65 DC | |
| 4 174 58 | Mounting Unit MPX ³ 100H 4 174 62 | MPX ³ 100H | CTX ³ 100 AC | |
| 4 174 59 | | | CTX ³ 100 DC | |

. Installation principle:

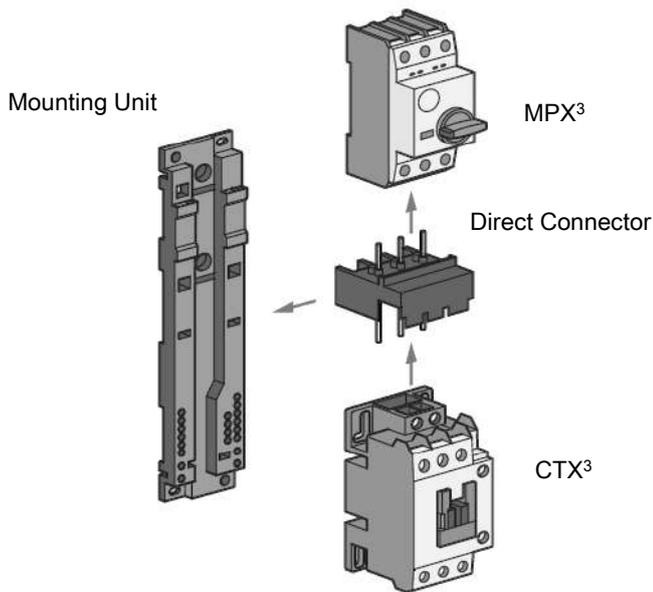

8. AUXILIARIES AND ACCESSORIES (continued)

Auxiliaries: (continued)

. Direct connector:



Overall dimensions Mounting unit:

. Mounting Unit MPX³ 32S / 32H / 32MA (cat n° 4 174 60)

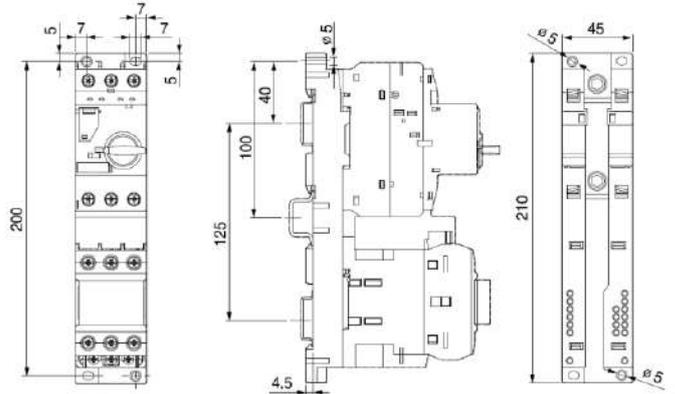

. Mounting Unit MPX³ 63H (cat n° 4 174 61)

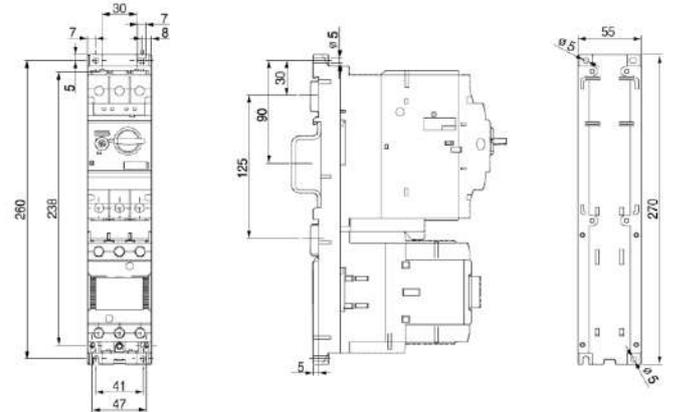

. Mounting Unit MPX³ 100H (cat n° 4 174 62)

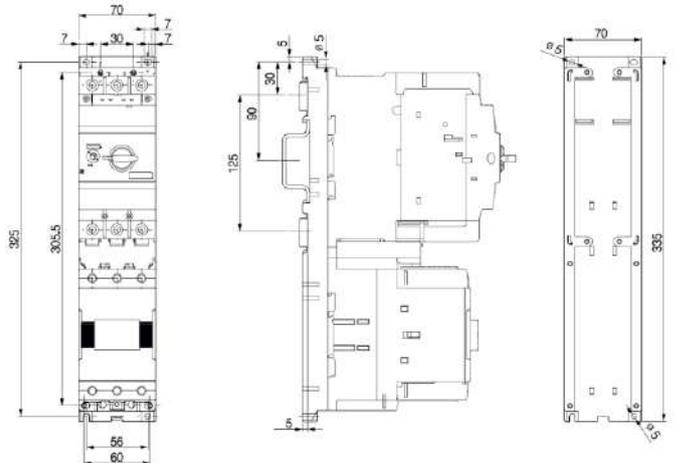

8. AUXILIARIES AND ACCESSORIES (continued)

Accessories: (continued)

. Dial Cover MPX³ (cat n° 4 174 79).

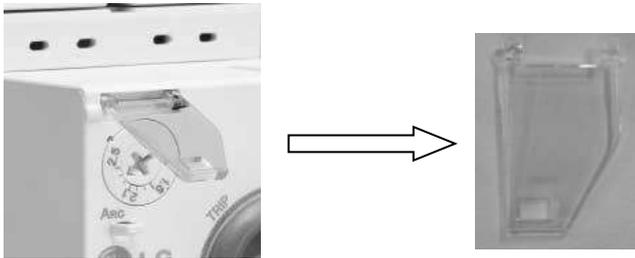

. Phase Busbar MPX³:

| References | Application MPX ³ | Number of breakers | Rated current |
|------------|-----------------------------------|--------------------|---------------|
| 4 174 71 | MPX ³ 32S / 32H / 32MA | 2 | 63 [A] |
| 4 174 73 | | 3 | |
| 4 174 75 | | 4 | |
| 4 174 76 | | 5 | |
| 4 174 72 | MPX ³ 63H | 2 | 108 [A] |
| 4 174 74 | | 3 | |



. Feeder 32A phase busbar for MPX³ 32S / 32H / 32 MA (cat n° 4 174 77).

| | |
|--------------------------------|--------------------------------------|
| Pole | 3P |
| Mounting location | Upstream |
| IP degree of protection | IP20 according to IEC 60 529 |
| Rated insulation voltage (Ui) | 690 [V] according to IEC 60 947-1 |
| Rated operational current (Ie) | 63 [A] |
| Terminal torque | 1.7 [Nm] on screw clamp terminals |

Installation software:

. XL PRO³.

8. AUXILIARIES AND ACCESSORIES (continued)

Accessories: (continued)

. Enclosure IP 65:

- Enclosure yellow red rotary handle MPX³ 32H / 32MA. (cat n° 4 174 80)
- Enclosure rotary handle MPX³ 32H / 32MA. (cat n° 4 174 81)



. Rotary handle:

- Rotary handle MPX³ 32H / 32MA (cat n° 4 174 63).
- Rotary handle MPX³ 63H (cat n° 4 174 64).
- Rotary handle MPX³ 100H (cat n° 4 174 65).



| References | Application MPX ³ | Shaft / Length |
|------------|------------------------------|----------------|
| 4 174 63 | MPX ³ 32H / 32MA | 315 [mm] |
| 4 174 64 | MPX ³ 63H | |
| 4 174 65 | MPX ³ 100H | |

- . Operation temperature : Min. = -20°C. Max. = +60°C.
- . Degree of protection : IP65 or UL50 Type 3R (separately).
- . Locking device : Lockable in ON / OFF position.
- . Material of insulation : Plastic (PA66).