

REV.	DATE	ECR NO.	DESCRIPTION
NC	10/21/11	XXXXXX	INITIAL RELEASE

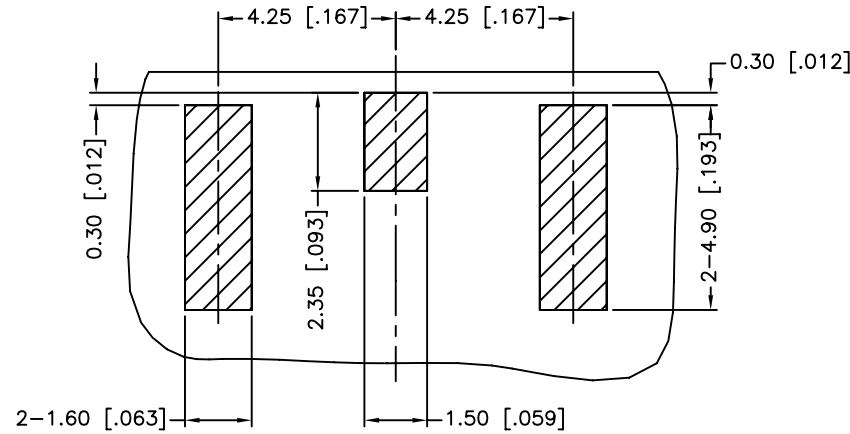

TOP VIEW

RECOMMENDED PCB LAYOUT

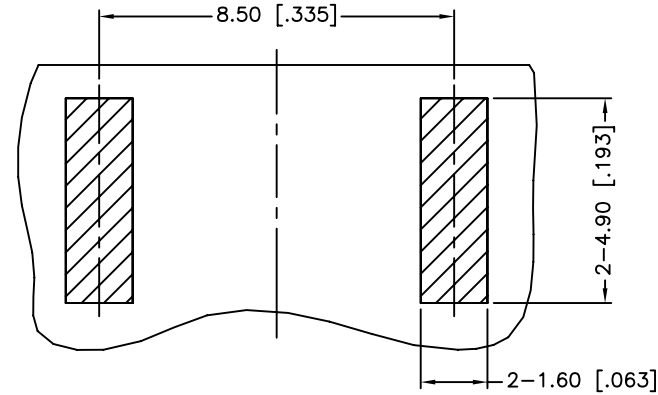

BOTTOM VIEW

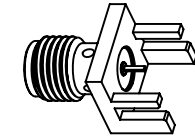

1/4-36UNS-2A

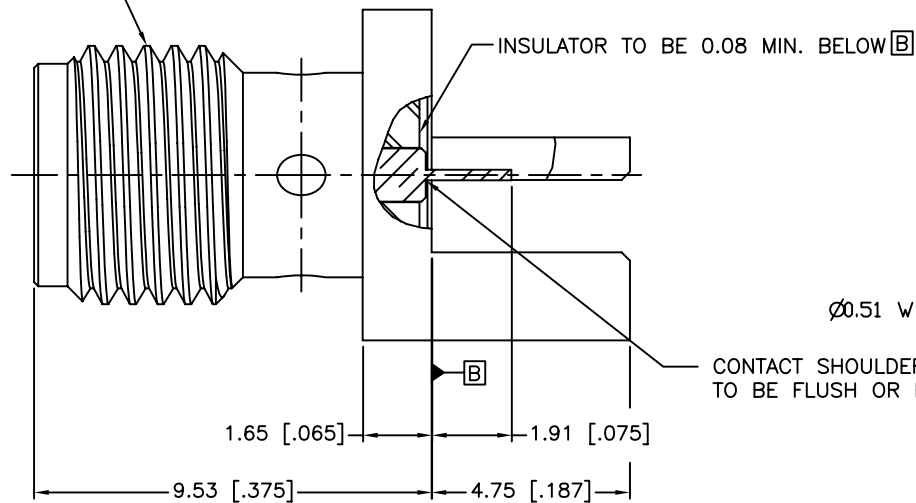

Ø0.51 WIDE X 0.25 THICK

CONTACT SHOULDER TO BE FLUSH OR BELOW B

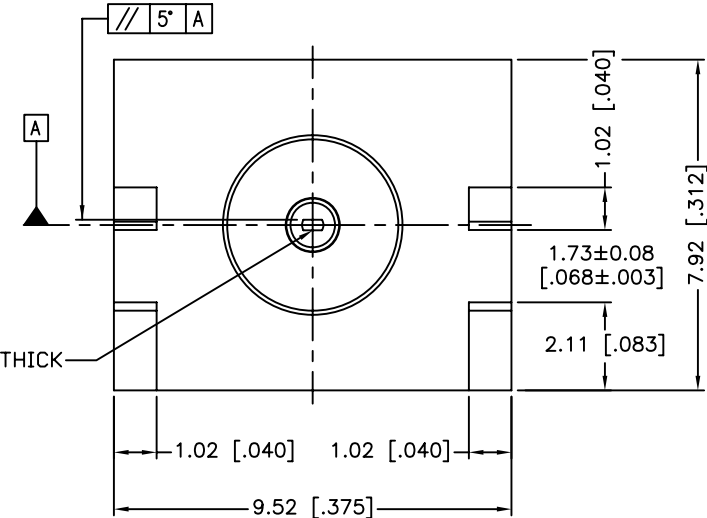

1. IMPEDANCE: 50 OHM
2. FREQUENCY RANGE: DC 0-18 GHZ
3. VSWR: NOT APPLICABLE
4. INSERTION LOSS: NOT APPLICABLE
5. DIELECTRIC WITHSTANDING VOLTAGE: 1000 VRMS, MIN.
6. DURABILITY: 500 CYCLES MIN.
7. CONTACT PIN MUST WITHSTAND 6 LBS MIN. AXIAL IN BOTH DIRECTIONS AND 4 IN-OZ MIN. RADIAL FORCE.
8. BOTTOM OF CONTACT TO BE IN LINE WITH MOUNTING LEG WITHIN .010"
9. BOARD THICKNESS=1.57 MM [.062"]

QTY	FINISH	MATERIAL	DESCRIPTION
1	GOLD	BER. COPPER	CONTACT PIN
1	NATURAL	PTFE	INSULATOR
1	GOLD	BRASS	BODY

UNLESS OTHERWISE SPECIFIED DIMENSIONS ARE IN MILLIMETERS. DIMENSIONS IN [] ARE IN INCHES AND FOR CUSTOMER REFERENCE ONLY.

UNLESS OTHERWISE SPECIFIED TOLERANCES FOR MILLIMETERS ARE:
0.5 - 8mm ± 0.20mm
8 - 30mm ± 0.40mm
30 - 120mm ± 0.50mm

UNLESS OTHERWISE SPECIFIED TOLERANCES FOR INCHES ARE:
.020 - .315 = ± 0.007"
.315 - 1.180 = ± 0.015"
1.180 - 4.724 = ± 0.020"

DO NOT SCALE DRAWING

APPROVALS	DATE
DRAWN M.ZHANG	10/21/11
CHECKED	
ISSUED	
SHEET 1 OF 1	
CAD FILE C:/CONNEX/132357-11.DWG	

Amphenol Connex

PART DESCRIPTION
SMA END LAUNCH RECEPT. JACK, FLUSH FLANGE FLAT-TAB CONTACT(.062" BOARD THICKNESS)
PART NO. 132357-11
DWG. NO. 132357-11.DWG REV. NC SIZE A SCALE NA