

Order Number
63819-4600

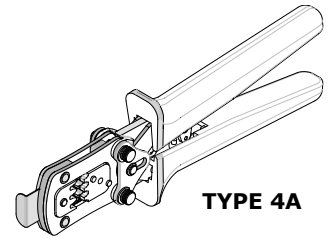

Application Tooling Specification



FEATURES

- A full cycle ratcheting hand tool ensures complete crimps
- Ergonomically designed soft handles
- Precisely designed crimping profiles with simple contact positioning
- Easy handling due to outstanding force ratio
- Modular crimp head is removable and can be used in the Electric Crimp Machine (Order No. 63816-1500), accompanied by Battery Powered Crimp Adapter (Order No. 63816-0600)
- Can also be used in the Battery Powered Tool Order No. 63816-0270 (110 V) or 63816-0280 (220 V), accompanied by Battery Powered Crimp Adapter (Order No. 63816-0600)

SCOPE

Products: 1.50mm (.059") Pitch CLIK-Mate Wire-to-Board Crimp Terminal 24-28 AWG (0.08 and 0.20mm²).

| Terminal Series No. | Terminal Order No. | | Wire Size | | | Insulation Diameter | | | | Strip Length | |
|---------------------|--------------------|-------------|-----------|-----------------|------------|---------------------|-----------|--------------|-----------|--------------|-----------|
| | | | | | | IPC/WHMA-A-620 (2) | | Terminal (3) | | | |
| | Loose Piece | Reel (1) | AWG | mm ² | Stranding | mm | In. | mm | In. | mm | In. |
| 502579 | 502579-0100 | 502579-0000 | 24 | — | 7 x 32 AWG | 0.97-1.20 | .038-.047 | 0.80-1.20 | .031-.047 | 1.50-1.90 | .059-.075 |
| | | | 26 | — | 7 x 34 AWG | 0.97-1.20 | .038-.047 | 0.80-1.20 | .031-.047 | | |
| | 502579-1100 | 502579-1000 | 28 | — | 7 x 36 AWG | 0.97-1.17 | .035-.046 | 0.80-1.20 | .031-.047 | | |
| | | | — | 0.20 | 7 x 0.18mm | 0.97-1.20 | .038-.047 | 0.80-1.20 | .031-.047 | | |
| | | | — | 0.08 | — | 0.97-1.17 | .035-.046 | 0.80-1.20 | .031-.047 | | |
| 213028 | 213028-1100 | 213028-1000 | 24 | — | 7 x 32 AWG | 0.97-1.20 | .038-.047 | 0.80-1.20 | .031-.047 | 1.50-1.90 | .059-.075 |
| | | | 26 | — | 7 x 34 AWG | 0.97-1.20 | .038-.047 | 0.80-1.20 | .031-.047 | | |
| | 213028-3100 | 213028-3000 | 24 | — | 7 x 32 AWG | 0.97-1.20 | .038-.047 | 0.80-1.20 | .031-.047 | | |
| | | | 26 | — | 7 x 34 AWG | 0.97-1.20 | .038-.047 | 0.80-1.20 | .031-.047 | | |
| 213028-7100 | 213028-7000 | 26 | — | 7 x 34 AWG | 0.97-1.20 | .038-.047 | 0.80-1.20 | .031-.047 | | | |

1. Customer to cut off terminal from reel: 0.15mm (.006") maximum cut-off tab.
2. To achieve optimum IPC/WHMA-A-620 Class 2 insulation crimps, use this insulation OD using UL1061 wire.
3. Overall insulation OD specification for terminal.

DEFINITION OF TERMS

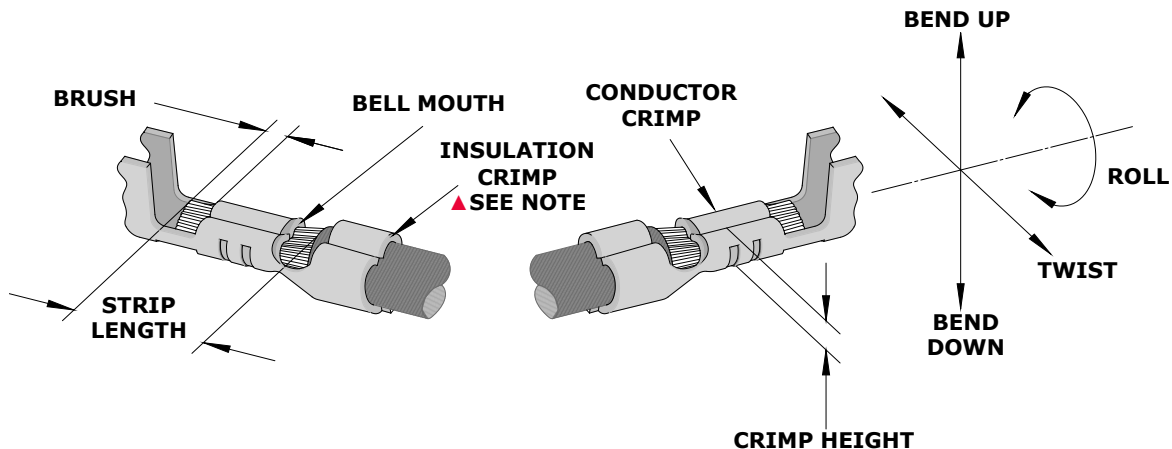

The above terminal drawing is a generic terminal representation. It is not an image of a terminal listed in the scope.

▲ Insulation Crimp Note

Due to the terminal’s insulation grip design or insulation diameter range, this tool uses overlap form geometry in the insulation punch. This produces an overlap insulation crimp (A-620-compliant). Although the insulation punch profile may appear lopsided, this is a normal condition for this tool. See figure to the right. Some tools with multiple crimp pockets may not have the overlap profile on all pockets.

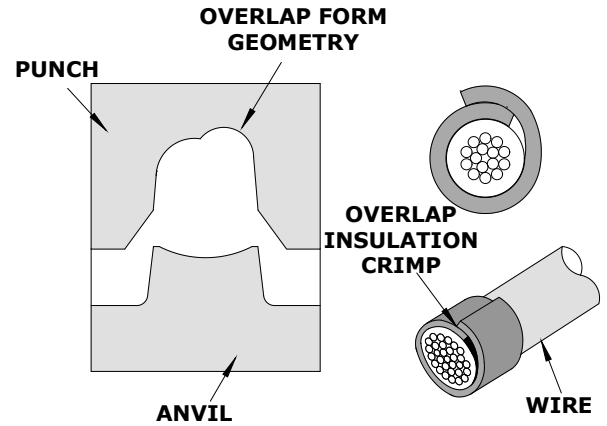

CRIMP SPECIFICATION

After crimping, the crimp profiles should measure the following:

| Terminal Series No. | Bell Mouth | | Cut-Off Tab Maximum | | Conductor Brush | |
|---------------------|------------|-----------|---------------------|------|-----------------|-----------|
| | mm | In. | mm | In. | mm | In. |
| 502579 213028 | 0.10-0.40 | .004-.016 | 0.10 | .004 | 0.10-0.60 | .004-.024 |

| Terminal Series No. | Wire Size | | Conductor Crimp | | | | Insulation Crimp | | | | Pull Force Minimum | | Profile | | |
|---------------------|-----------|-----------------|-----------------|-----------|-------------|-----|------------------|------|-------------|-----|--------------------|------|-------------------------------|-------------------------------|--------|
| | | | Height (Ref) | | Width (Ref) | | Height (Ref) | | Width (Ref) | | | | 28 AWG 0.08mm ² | 24 AWG 0.20mm ² | 26 AWG |
| | AWG | mm ² | mm | In. | mm | In. | mm | In. | mm | In. | N | Lb. | | | |
| 502579 | 24 | — | 0.60-0.65 | .024-.026 | — | — | 1.65 | .065 | — | — | 29.4 | 6.6 | | X | |
| | 26 | — | 0.59-0.64 | .023-.025 | — | — | 1.55 | .061 | — | — | 19.6 | 4.4 | | | X |
| | 28 | — | 0.56-0.61 | .022-.024 | — | — | 1.45 | .057 | — | — | 9.8 | 2.20 | X | | |
| | — | 0.20 | 0.60-0.65 | .024-.026 | — | — | 1.65 | .065 | — | — | 29.4 | 6.6 | | X | |
| | — | 0.08 | 0.56-0.61 | .022-.024 | — | — | 1.45 | .057 | — | — | 9.8 | 2.20 | X | | |
| 213028 | 24 | — | 0.60-0.65 | .024-.026 | — | — | 1.65 | .065 | — | — | 29.4 | 6.6 | | X | |
| | 26 | — | 0.59-0.64 | .023-.025 | — | — | 1.55 | .061 | — | — | 19.6 | 4.4 | | | X |

Tool Qualification Notes

1. Pull force should be measured with no influence from the insulation crimp.
2. The above specifications are guidelines to an optimal crimp.

Notes

1. This tool should only be used for the terminals and wire gauges specified on this sheet.
2. This tool is not adjustable for crimp height; however, crimp force is adjustable (see instructions above). Variations in tools, terminals, wire stranding and insulation types may affect crimp height.
3. This tool is intended for standard conductor sizes. It may not give a good insulation crimp support for all insulation sizes.
4. Molex does not repair hand tools (see warranty above). The replacement parts listed are the only parts available for repair. If the handles or crimp tooling are damaged or worn, a new tool must be purchased.
5. Pull force should be used as the final criterion for an acceptable crimp. Pull force is measured with no influence from the insulation crimp. The insulation should be stripped long (1/2”) so that the insulation grips on the terminal do not grip the wire insulation or the conductor. Refer to Molex Quality Crimping Handbook 63800-0029 for additional information on crimping and crimp testing.
6. Molex does not certify hand crimp tools.

OPERATION

Open the tool by squeezing the handles together. At the end of the closing stroke, the ratchet mechanism will release the handles, and the hand tool will spring open.

1. With the hand tool in the open position, pivot the terminal locator open by pulling up on the locator knob and lift the wire stop blade up. See Figure 1.
2. Insert the terminal into the correct profile until the terminal is fully seated and stops. Make sure the wire stop blade is fully seated on the terminal behind the conductor grip section.
3. Gently pivot the locator closed.
4. Bring down the wire stop blade.
5. Slide the pre-stripped wire into the terminal; make sure to aim the wire brush toward the tip point on the wire stop blade. See Figure 2. Align the wire so that it is parallel and sitting into the terminal. Maintain a light and constant pressure on the wire that is seated in the terminal at all times. (Do not let go of the wire.) Be sure to hold the wire and terminal in place until the terminal is fully crimped. See Figure 3.
6. Close the tool until the ratchet releases.
7. Lift the wire stop blade.
8. Carefully remove the crimped terminal.

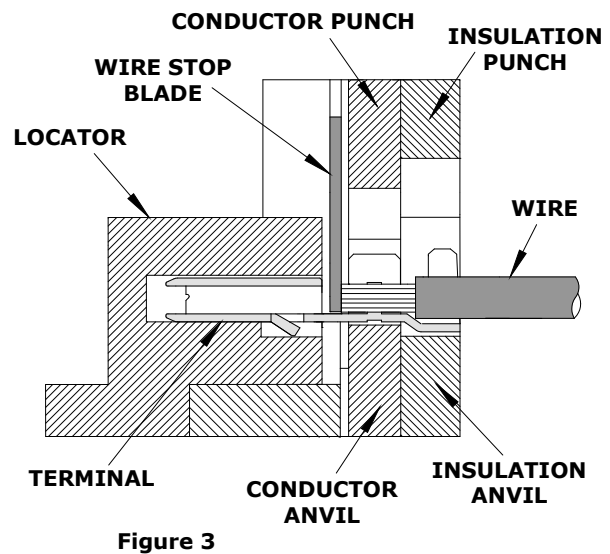
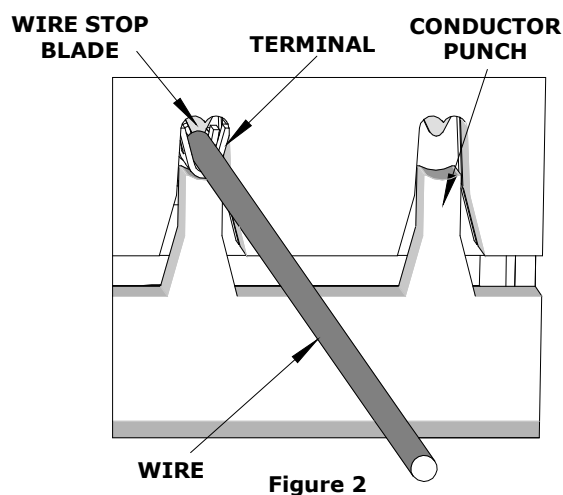
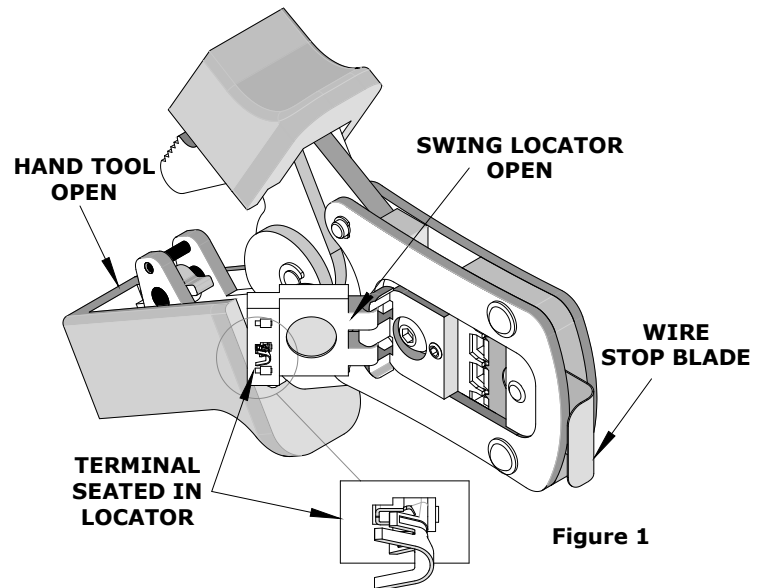

Note: To maintain a good brush control and a consistent bell mouth, the crimping instructions must be followed.

MAINTENANCE

It is recommended that each operator of the tool be made aware of and responsible for the following maintenance steps:

1. Remove dust, moisture and other contaminants with a clean brush or a soft, lint-free cloth.
2. Do not use any abrasive materials that could damage the tool.
3. Make certain all pins, pivot points and bearing surfaces are protected with a thin coat of high-quality machine oil. Do not oil excessively. The tool was engineered for durability, but like any other equipment, it needs cleaning and lubrication for a maximum service life of trouble-free crimping. Light oil (such as 30 weight automotive oil) used at the oil points every 5,000 crimps or 3 months will significantly enhance the tool life.
4. Wipe excess oil from hand tool, particularly from crimping area. Oil transferred from the crimping area onto certain terminations may affect the electrical characteristics of an application.
5. When the tool is not in use, keep the handles closed to prevent objects from becoming lodged in the crimping dies, and store the tool in a clean, dry area.

Miscrimps or Jams

Should this tool ever become stuck or jammed in a partially closed position, **do not force the handles open or closed**. The tool will open easily by lifting the ratchet release lever. See Figure 7.

Warranty

This tool is for electrical terminal crimping purposes only. This tool is made of the best quality materials. All vital components are long life tested. All tools are warranted to be free of manufacturing defects for a period of 30 days. Should such a defect occur, Molex will repair or exchange the tool free of charge. This repair or exchange will not be applicable to altered, misused or damaged tools. This tool is designed for hand use only. Any clamping, fixturing or use of handle extensions voids this warranty.

CAUTION: Repetitive use of this tool should be avoided.

CAUTIONS

1. Manually powered hand tools are intended for low-volume use or field repair. This tool is **NOT** intended for production use. Repetitive use of this tool should be avoided.
2. Insulated rubber handles are not protection against electrical shock.
3. Wear eye protection at all times.
4. Use only the Molex terminals specified for crimping with this tool.

CAUTION: Molex crimp specifications are valid only when used with Molex terminals and tooling.

APPLICATIONS FOR THE MODULAR CRIMP HEAD

WARNING: NEVER operate, service, install or adjust this modular crimp head without proper instruction and without first reading and understanding the instructions in the proper manual or specification sheet. See chart below for the correct manual or specification sheet.

WARNING: NEVER install tooling or service this tool while it is plugged into any power source. Disconnect the power by unplugging, or turn off the actuator from its power source.

CAUTION: Keep fingers away from the crimping area when operating this tool. It may cause severe injury.

CAUTION: Wear safety glasses when operating or serving this tool.

The chart below shows all applications for this modular crimp head:

| Tool Order No. | Tool Description | Adapter Order No. | Adapter Description | Figure No. |
|----------------|----------------------------|-------------------|-----------------------------|------------|
| 63816-0000 | Hand Crimp Frame (Short) | — | — | 4 |
| 63816-0050 | Hand Crimp Frame (Long) | — | — | 4 |
| 63816-0270 | Battery Power Tool (110 V) | 63816-0600 | Battery Power Crimp Adapter | 5 |
| 63816-0280 | Battery Power Tool (220 V) | 63816-0600 | Battery Power Crimp Adapter | 5 |
| 63816-1500 | Electric Crimp Machine | 63816-0600 | Battery Power Crimp Adapter | 6 |

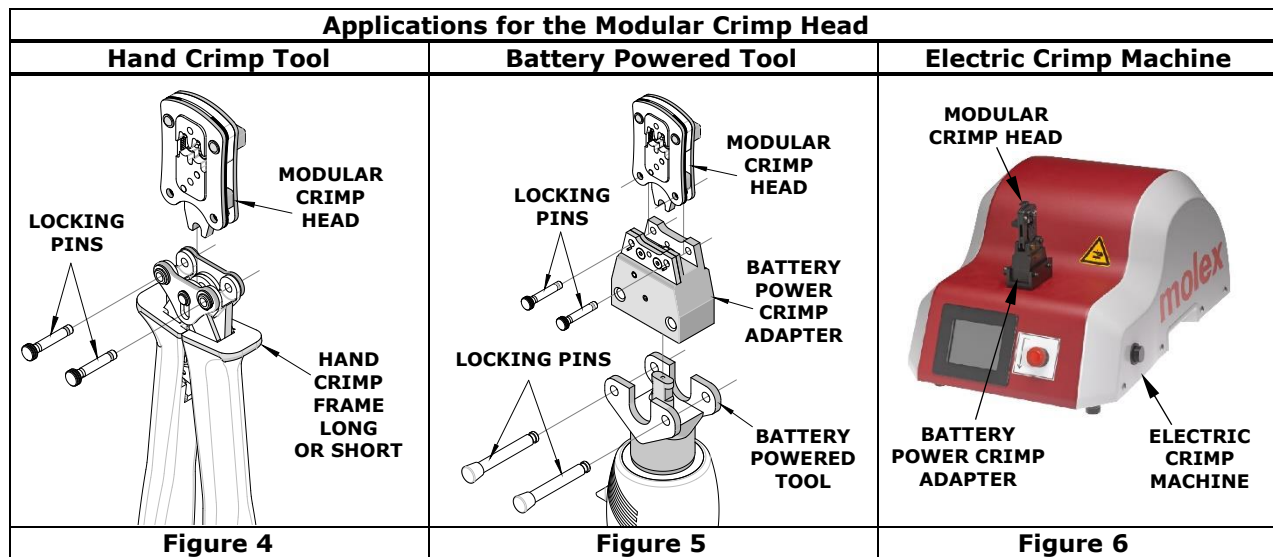

PARTS LIST

| Hand Crimp Tool 63819-4600 | | | |
|----------------------------|--------------|--------------------------|----------|
| Item | Order Number | Description | Quantity |
| 1 | 63816-0000 | Hand Crimp Frame (Short) | 1 |
| 2 | 63819-4675 | Locator | 1 |
| 3 | 63816-0001 | Locking Pin | 2 |
| 4 | 63600-0525 | Handle Spring | 1 |
| 5 | 63600-0520 | Crimping Spring | 2 |

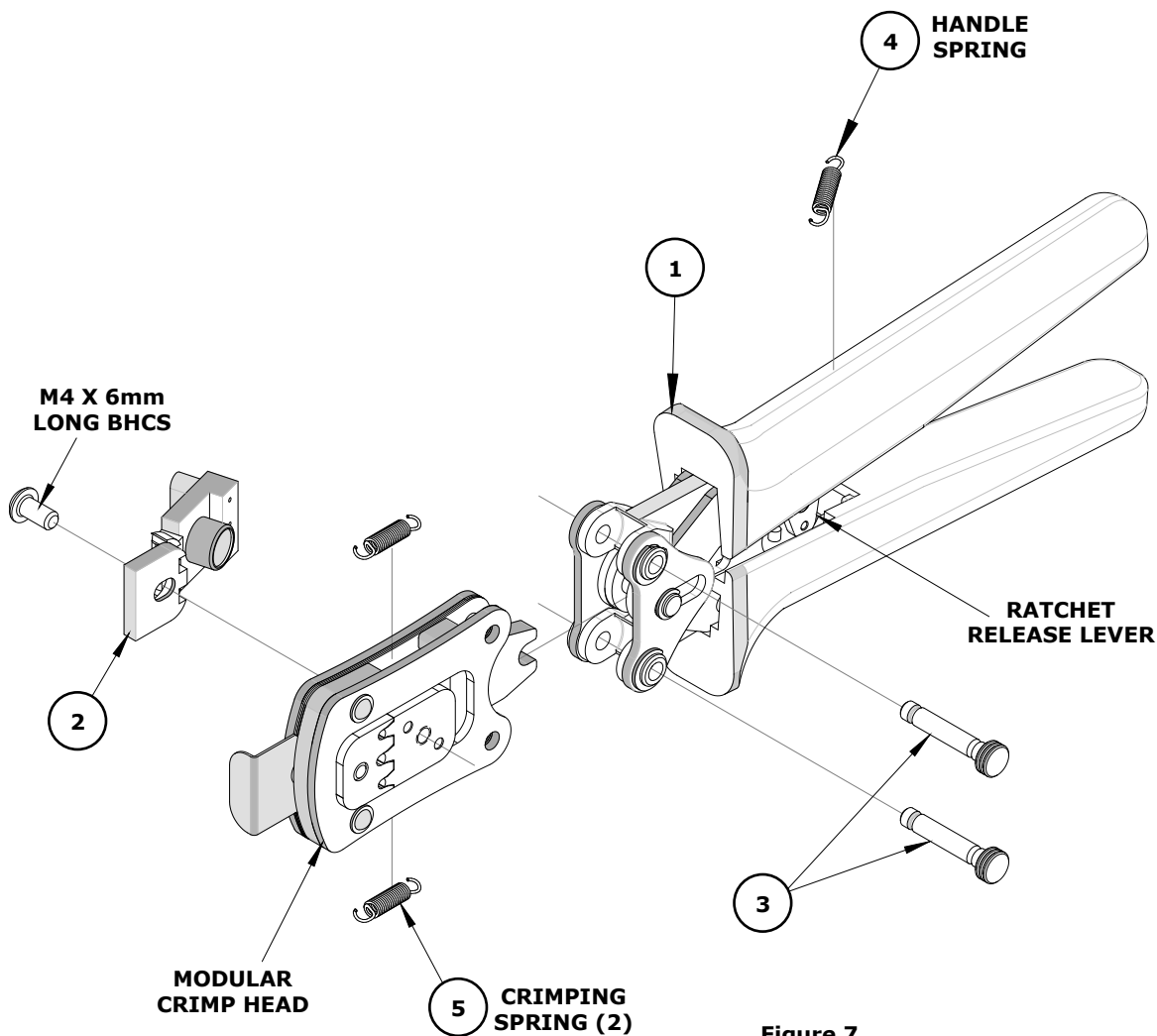

Application Tooling Support

Phone: (402) 458-TOOL (8665)
E-Mail: applicationtooling@molex.com
Website: www.molex.com/applicationtooling

Molex is a registered trademark of Molex, LLC in the United States of America and may be registered in other countries; all other trademarks listed herein belong to their respective owners.