

Limit switches







OsiSense XC Standard

Industrial format EN 50041

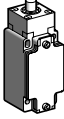



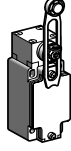





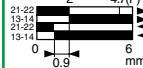

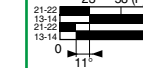



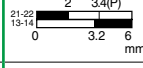
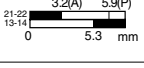
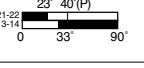
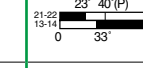
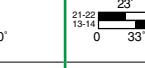



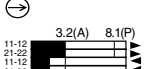







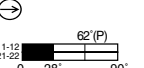





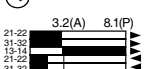

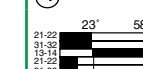
Metal, conforming to CENELEC EN 50041, type XCK J

Complete fixed body switches with 1 cable entry

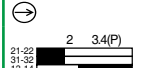
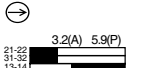
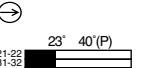
1

Type of head	Plunger (fixing by the body)		Rotary (fixing by the body) (switches supplied for actuation from left AND right)			
	Form B (1)	Form C (1)	Form A (1)			Form D (1)
						
Type of operator	Metal end plunger	Steel roller plunger	Thermoplastic roller lever (2)	Steel roller lever (2)	Variable length thermoplastic roller lever (2)	Round thermoplastic rod lever, Ø 6 mm (2) (4)

References of complete switches with 1 ISO M20 x 1.5 cable entry(3)

	2-pole NC + NO snap action (XE2S P2151)	XCK J161H29 	XCK J167H29 	XCK J10511H29 	XCK J10513H29 	XCK J10541H29 	XCK J10559H29 
	2-pole NC + NO break before make, slow break (XE2N P2151)	XCK J561H29 	XCK J567H29 	XCK J50511H29 	XCK J50513H29 	XCK J50541H29 	XCK J50559H29 
	2-pole NC + NC snap action (XE2S P2141)	ZCK J9H29 + ZCK E61 	ZCK J9H29 + ZCK E67 	ZCK J9H29 + ZCK E05 + ZCK Y11 	ZCK J9H29 + ZCK E05 + ZCK Y13 	ZCK J9H29 + ZCK E05 + ZCK Y41 	ZCK J9H29 + ZCK E05 + ZCK Y59 
	2-pole NC + NC simultaneous, slow break (XE2N P2141)	ZCK J7H29 + ZCK E61 	ZCK J7H29 + ZCK E67 	ZCK J7H29 + ZCK E05 + ZCK Y11 	ZCK J7H29 + ZCK E05 + ZCK Y13 	ZCK J7H29 + ZCK E05 + ZCK Y41 	ZCK J7H29 + ZCK E05 + ZCK Y59 
	3-pole NC + NC + NO snap action (XE3S P2141)	ZCK JD39H29 + ZCK E61 	ZCK JD39H29 + ZCK E67 	ZCK JD39H29 + ZCK E05 + ZCK Y11 	ZCK JD39H29 + ZCK E05 + ZCK Y13 	ZCK JD39H29 + ZCK E05 + ZCK Y41 	ZCK JD39H29 + ZCK E05 + ZCK Y59 
	3-pole NC + NC + NO break before make, slow break (XE3N P2141)	ZCK JD37H29 + ZCK E61 	ZCK JD37H29 + ZCK E67 	ZCK JD37H29 + ZCK E05 + ZCK Y11 	ZCK JD37H29 + ZCK E05 + ZCK Y13 	ZCK JD37H29 + ZCK E05 + ZCK Y41 	ZCK JD37H29 + ZCK E05 + ZCK Y59 
Weight (kg)	0.430	0.455	0.480	0.490	0.485	0.485	
Contact operation	 closed  open		(A) = cam displacement (P) = positive opening point			 NC contact with positive opening operation	

References of complete switches with 1 Pg 13.5 cable entry (2)

For complete switches with entry for Pg 13.5 cable gland, delete H29 from the end of the reference. Example: XCK J161H29 becomes XCK J161.

References of complete switches with 1 entry for 1/2" NPT conduit (2)

For complete switches with entry for 1/2" NPT (USAS B2-1) conduit, replace H29 at the end of the reference by H7. Example: XCK J161H29 becomes XCK J161H7.

(1) Form conforming to EN 50041, see page 1/177.

(2) Adjustable throughout 360° in 5° steps, or in 45° steps by reversing the lever or its mounting.

(3) Switches with gold contacts or eyelet type connections: please consult our Customer Care Centre.

(4) Value taken with actuation by moving part at 100 mm from the fixing.

Limit switches

OsiSense XC Standard

Industrial format EN 50041

Metal, conforming to CENELEC EN 50041, type XCK J

Complete fixed body switches with 1 cable entry

Characteristics

Switch actuation	On end	By 30° cam			By any moving part
Type of actuation					
Maximum actuation speed	0.5 m/s	1 m/s	1.5 m/s		
Mechanical durability (1) (in millions of operating cycles)	30	25	30		
Minimum force or torque	For tripping	20 N	16 N	0.25 N.m	
	For positive opening	50 N	40 N	0.50 N.m	
Cable entry (3)	1 entry tapped M20 x 1.5 mm for ISO cable gland, clamping capacity 9 to 12 mm				

(1) Limited to 15 million operating cycles for switches with contacts XE3•P.

Dimensions

XCK J•61H29
ZCK J• + ZCK E61

XCK J•67H29
ZCK J• + ZCK E67

XCK J•051•H29
ZCK J• + ZCK E05 + ZCK Y11 or Y13

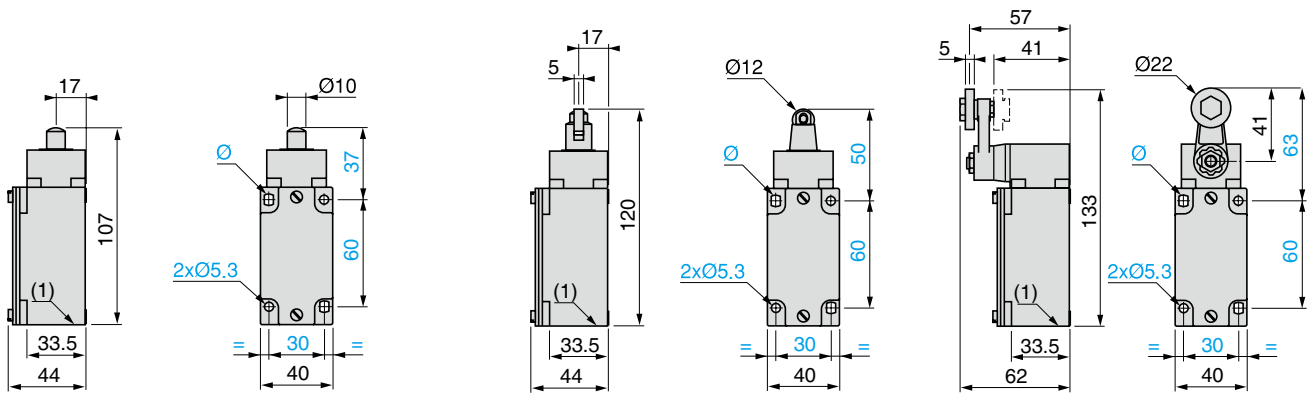

XCK J•0541H29
ZCK J• + ZCK E05 + ZCK Y41

XCK J•0559H29
ZCK J• + ZCK E05 + ZCK Y59

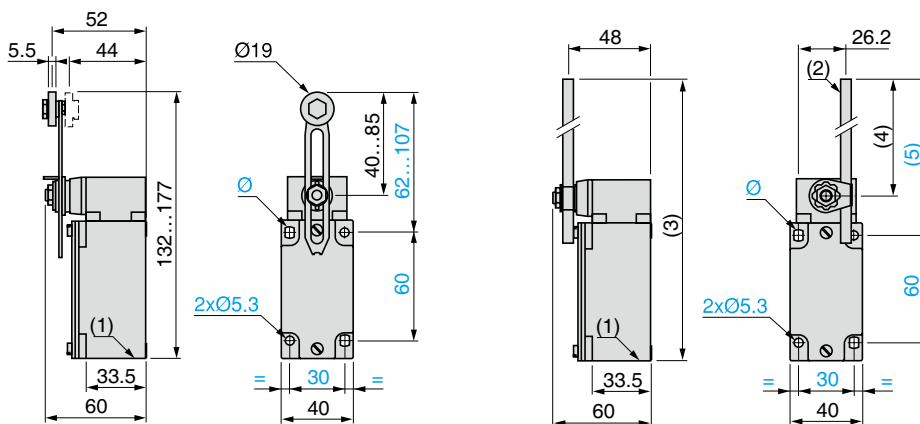

(1) 1 tapped entry for ISO M20 x 1.5 or Pg 13.5 cable gland or tapped 1/2" NPT.

(2) Ø 6 rod, length 200 mm.

(3) 282 max.

(4) 190 max.











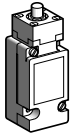
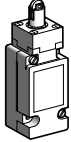

(5) 212 max.

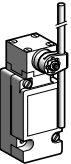
Ø: 2 elongated holes Ø 5.3 x 7.3.

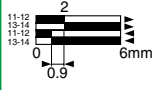
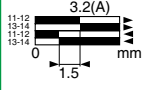
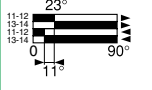
Limit switches

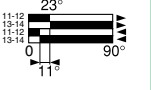
OsiSense XC Standard, industrial format EN 50041
Metal, conforming to CENELEC EN 50041, type XCK J
Complete switches, plug-in body
With 1 cable entry

1

Type of head	Plunger (fixing by the body)		Rotary (fixing by the body) (switches supplied for actuation from left AND right)			
	Form B (1)	Form C (1)	Form A (1)		Form D (1)	
						
Type of operator	Metal end plunger	Steel roller plunger	Thermoplastic roller lever (2)	Steel roller lever (2)	Variable length thermoplastic roller lever (2)	Round thermoplastic rod lever, Ø 6 mm (2) (4)
References of complete switches with 1 ISO M20 x 1.5 cable entry (3)						
 Single-pole CO snap action	XCK J1161H29	XCK J1167H29	XCK J110511H29	XCK J110513H29	XCK J110541H29	XCK J11059H29
						
Weight (kg)	0.430	0.455	0.480	0.490	0.485	0.485
Contact operation	 closed  open		(A) = cam displacement			



References of complete switches with 1 Pg 13.5 cable entry (3)

For complete switches with entry for Pg 13.5 cable gland, delete **H29** from the end of the reference.
Example: **XCK J1161H29** becomes **XCK J1161**.

References of complete switches with 1 entry for 1/2" NPT conduit (3)

For complete switches with entry for 1/2" NPT (USAS B2-1) conduit, replace **H29** at the end of the reference by **H7**.
Example: **XCK J1161H29** becomes **XCK J1161H7**.

Characteristics

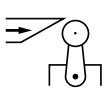
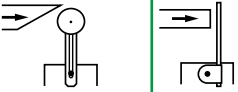
Switch actuation	On end	By 30° cam		By any moving part
Type of actuation				
Maximum actuation speed	0.5 m/s	1 m/s	1.5 m/s	
Mechanical durability (in millions of operating cycles)	30	25	30	
Minimum tripping force or torque	20 N	16 N	0.25 N.m	
Cable entry	1 entry tapped M20 x 1.5 for ISO cable gland Clamping capacity 7 to 13 mm			

(1) Form conforming to EN 50041, see page 1/177.

(2) Adjustable throughout 360° in 5° steps, or in 45° steps by reversing the lever or its mounting.

(3) Switches with gold contacts: please consult our Customer Care Centre.

(4) Value taken with actuation by moving part at 100 mm from the fixing.

Limit switches

OsiSense XC Standard, industrial format EN 50041
 Metal, conforming to CENELEC EN 50041, type XCK J
 Complete switches, plug-in body
 With 1 cable entry

XCK J1611H29

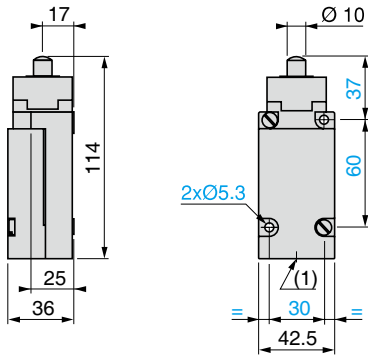

XCK J1167H29

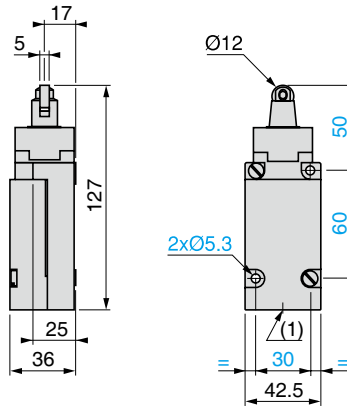

XCK J110511H29, XCK J110513H29

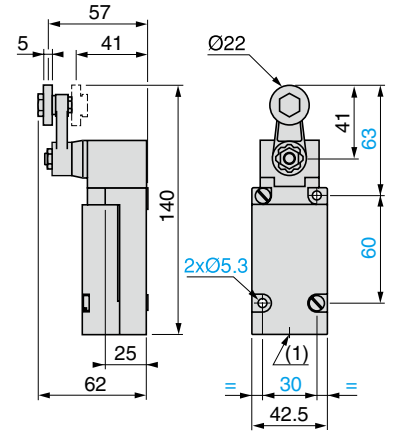

XCK J110541H29

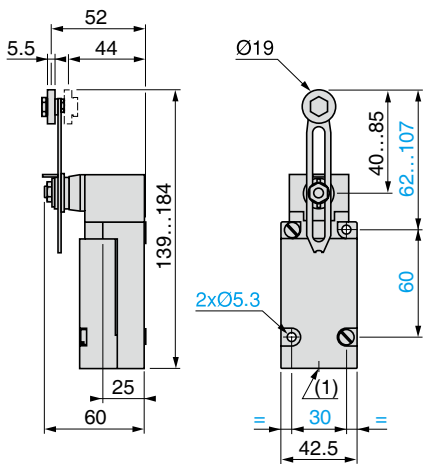

XCK J110559H29

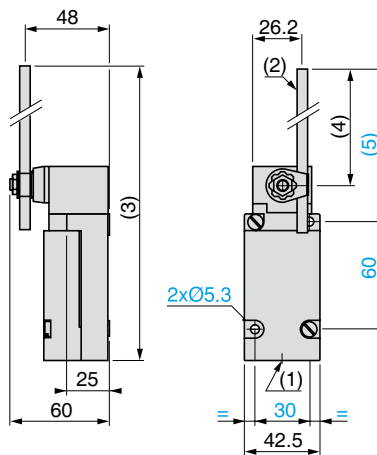

(1) 1 tapped entry for ISO M20 x 1.5 or Pg 13.5 cable gland or for 1/2" NPT conduit.
 (2) Ø 6 rod, length 200 mm.
 (3) 289 max.
 (4) 190 max.
 (5) 212 max.

Limit switches

OsiSense XC Standard, industrial format EN 50041
Metal, conforming to CENELEC EN 50041, type XCK J
Complete switches, fixed body
M12 connector

1

Type of head	Plunger (fixing by the body)		Rotary (fixing by the body) (switches supplied for actuation from left AND right)			
	Form B (1)	Form C (1)	Form A (1)		Form D (1)	
Type of operator	Metal end plunger	Steel roller plunger	Thermoplastic roller lever (2)	Steel roller lever (2)	Variable length thermoplastic roller lever (2)	Round thermoplastic rod lever, Ø 6 mm (2) (3)

References (4)	2-pole NC + NO snap action (XE2S P2151)					
		XCK J161D 	XCK J167D 	XCK J10511D 	XCK J10513D 	XCK J10541D
Weight (kg)	0.430	0.455	0.480	0.490	0.485	0.485
Contact operation	closed open		(A) = cam displacement (P) = positive opening point			

Characteristics				
Switch actuation	On end	By 30° cam		By any moving part
Type of actuation				
Maximum actuation speed	0.5 m/s	1 m/s	1.5 m/s	
Mechanical durability (in millions of operating cycles)	30	25	30	
Minimum force or torque	For tripping	20 N	16 N	0.25 N.m
	For positive opening	50 N	40 N	0.50 N.m
Connection	M12 connector, U _i = 60 V, I _e = 4 A (see suitable pre-wired female connectors below).			

- (1) Form conforming to EN 50041, see page 1/177.
- (2) Adjustable throughout 360° in 5° steps, or in 45° steps by reversing the lever or its mounting.
- (3) Value taken with actuation by moving part at 100 mm from the fixing.
- (4) Switches with gold contacts: please consult our Customer Care Centre.

References of suitable pre-wired female connectors		
Type of connector	M12 straight, 5-pin, 4 A/24 V max.	M12 elbowed, 5-pin, 4 A/24 V max.
With cable, Ø 5.8 mm (4 x 0.34 mm ² + 1 x 0.5 mm ²)	L = 2 m	XZ CP1164L2
	L = 5 m	XZ CP1164L5
	L = 10 m	XZ CP1164L10
Weight (kg)	L = 2 m	0.115
	L = 5 m	0.270
	L = 10 m	0.520

Limit switches

OsiSense XC Standard, industrial format EN 50041
Metal, conforming to CENELEC EN 50041, type XCK J
Complete switches, fixed body
M12 connector

Dimensions

XCK J161D

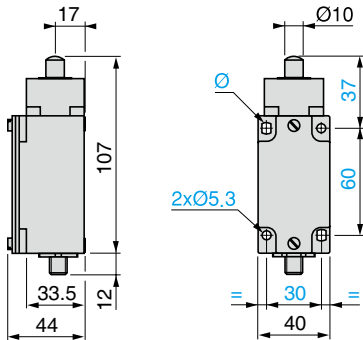

XCK J167D

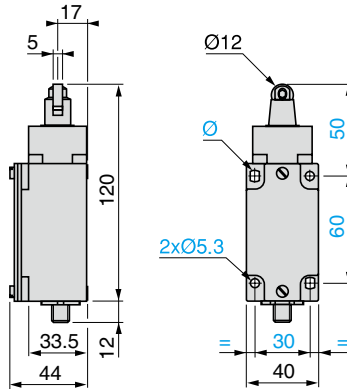

XCK J1051●D

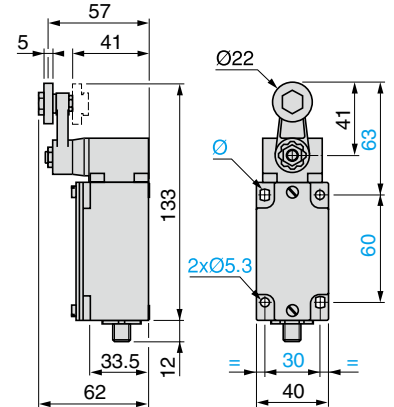

XCK J10541D

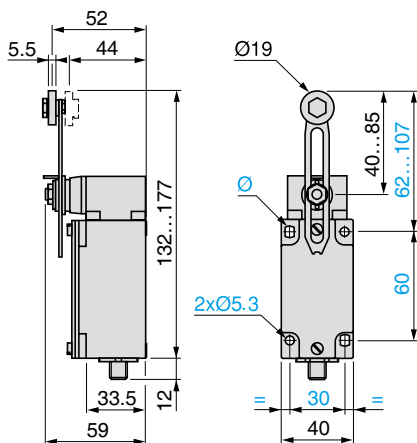

XCK J10559D

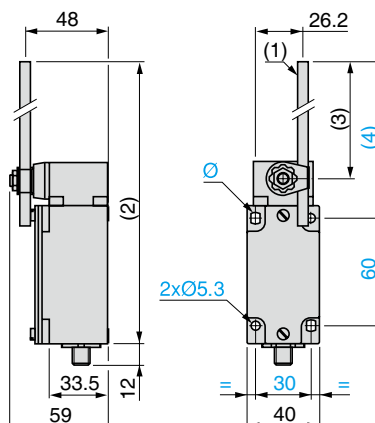

XZ CP1164L●

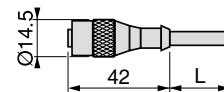

XZ CP1264L●

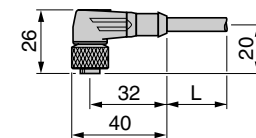

- (1) Ø 6 rod, length 200 mm.
- (2) 282 max.
- (3) 190 max.
- (4) 212 max.
- Ø: 2 elongated holes Ø 5.3 x 7.3.
- L: Cable length 2, 5 or 10 m.

Connections

Limit switch XCK J●●●●D

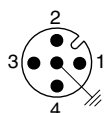

1-2 = NC
3-4 = NO
5 = \perp
4 A / 24 V max.

Pre-wired female connector XZ CP1●64L●

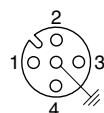







1 = brown
2 = white
3 = blue
4 = black
5 = \perp yellow/green

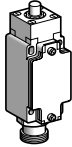
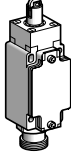
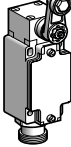
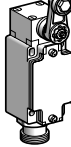
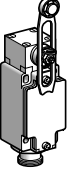
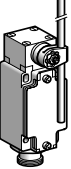



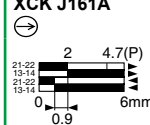
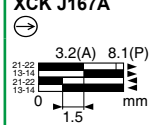
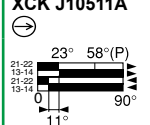
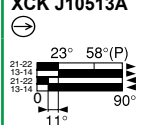
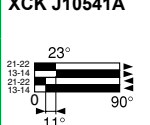
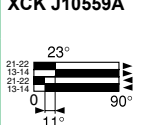

Limit switches

OsiSense XC Standard, industrial format EN 50041
Metal, conforming to CENELEC EN 50041, type XCK J
Complete switches, fixed body
7/8"-16UN connector

1

Type of head	Plunger (fixing by the body)		Rotary (fixing by the body) (switches supplied for actuation from left AND right)			
	Form B (1)	Form C (1)	Form A (1)		Form D (1)	
						
Type of operator	Metal end plunger	Steel roller plunger	Thermoplastic roller lever (2)	Steel roller lever (2)	Variable length thermoplastic roller lever (2)	Round thermoplastic rod lever, Ø 6 mm (2) (3)

References (4)	2-pole NC + NO snap action (XE2S P2151)					
	XCK J161A	XCK J167A	XCK J10511A	XCK J10513A	XCK J10541A	XCK J10559A
						
Weight (kg)	0.430	0.455	0.480	0.490	0.485	0.485
Contact operation	 closed  open		(A) = cam displacement (P) = positive opening point		 NC contact with positive opening operation	

Characteristics							
Switch actuation	On end	By 30° cam			By any moving part		
Type of actuation							
Maximum actuation speed	0.5 m/s	1 m/s	1.5 m/s				
Mechanical durability (in millions of operating cycles)	30	25	30				
Minimum force or torque	For tripping	20 N	16 N	0.25 N.m			
	For positive opening	50 N	40 N	0.50 N.m			
Connection	7/8"-16UN connector, Ui = 250 V; Ie = 6 A (see suitable pre-wired female connectors below).						

- (1) Form conforming to EN 50041, see page 1/177.
- (2) Adjustable throughout 360° in 5° steps, or in 45° steps by reversing the lever or its mounting.
- (3) Value taken with actuation by moving part at 100 mm from the fixing.
- (4) Switches with gold contacts: please consult our Customer Care Centre.

References of suitable pre-wired female connectors		
Type of connector	7/8"-16UN straight, 5-pin, 6 A/250 V max.	
With cable, Ø 6.7 mm (5 x 0.5 mm ²)	L = 2 m	XZ CP1771L2
	L = 5 m	XZ CP1771L5
	L = 10 m	XZ CP1771L10
Weight (kg)	L = 2 m	0.190
	L = 5 m	0.475
	L = 10 m	0.950

Limit switches

OsiSense XC Standard, industrial format EN 50041
Metal, conforming to CENELEC EN 50041, type XCK J
Complete switches, fixed body
7/8"-16UN connector

Dimensions

XCK J161A

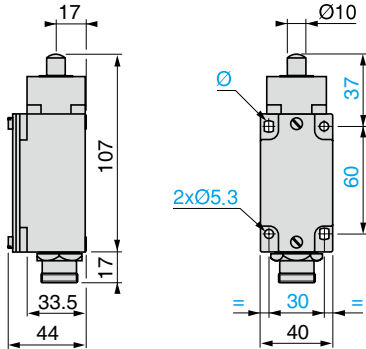

XCK J167A

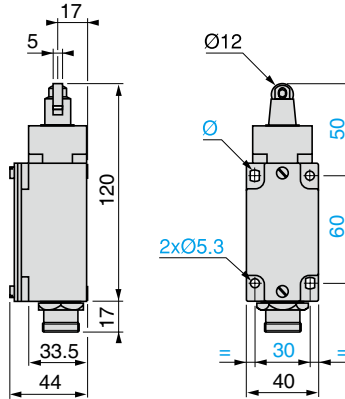

XCK J1051●A

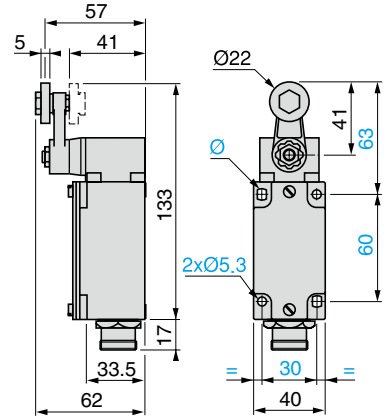

XCK J10541A

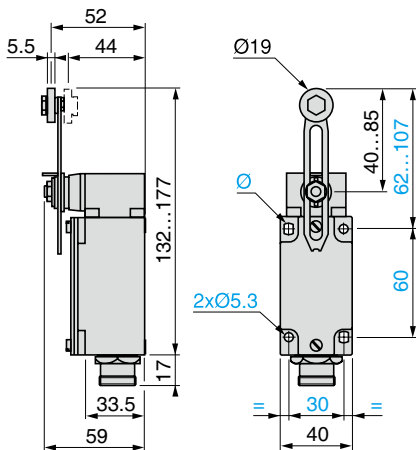

XCK J10559A

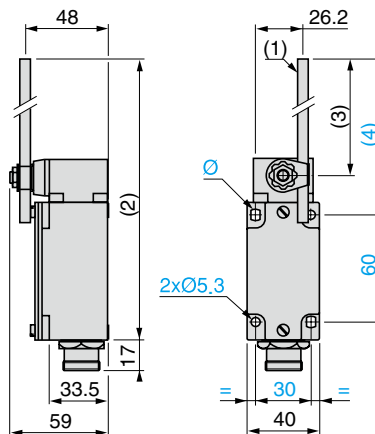

XZ CP1771L●

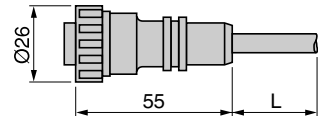

- (1) Ø 6 rod, length 200 mm.
- (2) 282 max.
- (3) 190 max.
- (4) 212 max.
- Ø: 2 elongated holes Ø 5.3 x 7.3.
- L: Cable length 2, 5 or 10 m.

Connections

Limit switch XCK J●●●●A

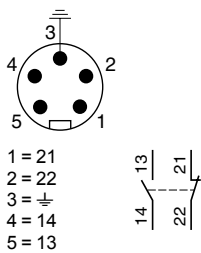

Pre-wired female connector XZ CP1771L●

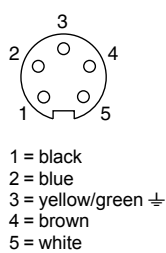

■ **XCK J**
fixed body with 1 cable entry

□ With head for linear movement (plunger)

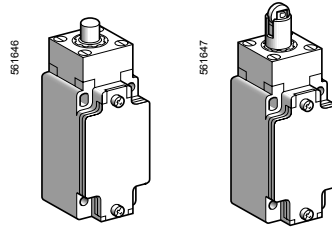

Page 1/102

□ With head for rotary movement (lever)

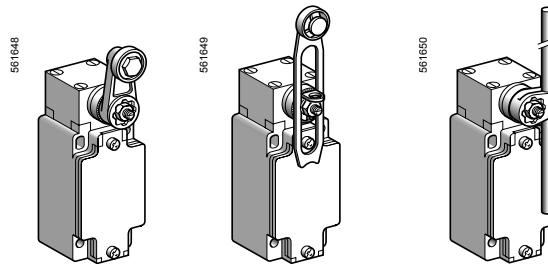

Page 1/102

■ **XCK J**
plug-in body with 1 cable entry

□ With head for linear movement (plunger)

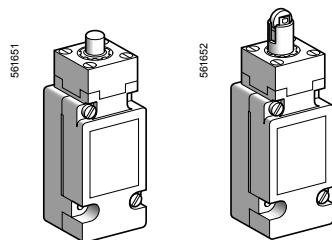

Page 1/104

□ With head for rotary movement (lever)

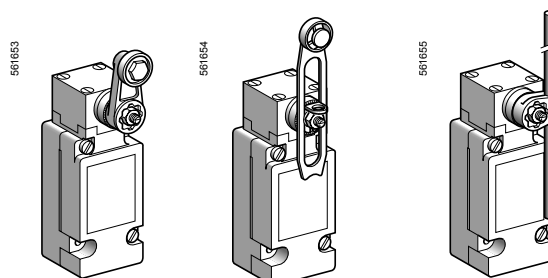

Page 1/104

Environment characteristics

Conformity to standards	Products	IEC 60947-5-1, EN 60947-5-1, UL 508, CSA C22-2 n° 14
	Machine assemblies	IEC 60204-1, EN 60204-1
Product certifications		UL, CSA, CCC
Protective treatment	Version	Standard: "TC", special: "TH"
Ambient air temperature	For operation	- 25...+ 70°C, special sub-assemblies for use at - 40°C or + 120°C
	For storage	- 40...+ 70°C
Vibration resistance	Conforming to IEC 60068-2-6	25 gn (10...500 Hz)
Shock resistance	Conforming to IEC 60068-2-27	50 gn (11 ms)
Electric shock protection		Class I conforming to IEC 61140 and NF C 20-030
Degree of protection		IP 66 conforming to IEC 60529; IK 07 conforming to EN 50102
Repeat accuracy		0.01 mm on the tripping points, with 1 million operating cycles for head with end plunger
Cable entry or connector	Depending on model	Tapped entry for n° 13 cable gland, tapped ISO M20 x 1.5 or tapped 1/2" NPT, or M12 connector
Materials		Bodies and heads in zamak

Contact block characteristics		
Rated operational characteristics	XE2● P	~AC-15; A300 (Ue = 240 V, Ie = 3 A); Ithe = 10 A ---DC-13; Q300 (Ue = 250 V, Ie = 0.27 A), conforming to IEC 60947-5-1 Appendix A, EN 60947-5-1
	XE3● P	~AC-15; B300 (Ue = 240 V, Ie = 1.5 A); Ithe = 6 A ---DC-13; R300 (Ue = 250 V, Ie = 0.1 A), conforming to IEC 60947-5-1 Appendix A, EN 60947-5-1
Rated insulation voltage	XE2● P	Ui = 500 V degree of pollution 3 conforming to IEC 60947-1 Ui = 300 V conforming to UL 508, CSA C22-2 n° 14
	XE3● P	Ui = 400 V degree of pollution 3 conforming to IEC 60947-1 Ui = 300 V conforming to UL 508, CSA C22-2 n° 14
Rated impulse withstand voltage	XE2● P	U imp = 6 kV conforming to IEC 60947-1, IEC 60664
	XE3● P	U imp = 4 kV conforming to IEC 60947-1, IEC 60664
Positive operation (depending on model)		NC contacts with positive opening operation conforming to IEC 60947-5-1 Appendix K, EN 60947-5-1
Resistance across terminals		≤ 25 mΩ conforming to IEC 60255-7 category 3
Short-circuit protection	XE2● P	10 A cartridge fuse type gG (gl)
	XE3● P	6 A cartridge fuse type gG (gl)
Connection (screw clamp terminals)	XE2S P21●1	Clamping capacity, min: 1 x 0.34 mm ² , max: 2 x 1.5 mm ²
	XE2N P21●1	Clamping capacity, min: 1 x 0.5 mm ² , max: 2 x 2.5 mm ²
	XCK J plug-in and XES P20●1	Clamping capacity, min: 1 x 0.75 mm ² , max: 2 x 1.5 mm ²
	XE3N P and XE3S P	Clamping capacity, min: 1 x 0.34 mm ² , max: 1 x 1 mm ² or 2 x 0.75 mm ²
Minimum actuation speed		XE2S P21●1 and XE3S P: 0.01 m/minute
		XE2N P21●1 and XE3N P: 6 m/minute

Electrical durability

- Conforming to IEC 60947-5-1 Appendix C
- Utilisation categories AC-15 and DC-13
- Maximum operating rate: 3600 operating cycles/hour
- Load factor: 0.5

