

Jun.1.2020 Copyright 2020 HIROSE ELECTRIC CO., LTD. All Rights Reserved.  
In case of consideration for using Automotive equipment / device which demand high reliability, kindly contact our sales window correspondents.

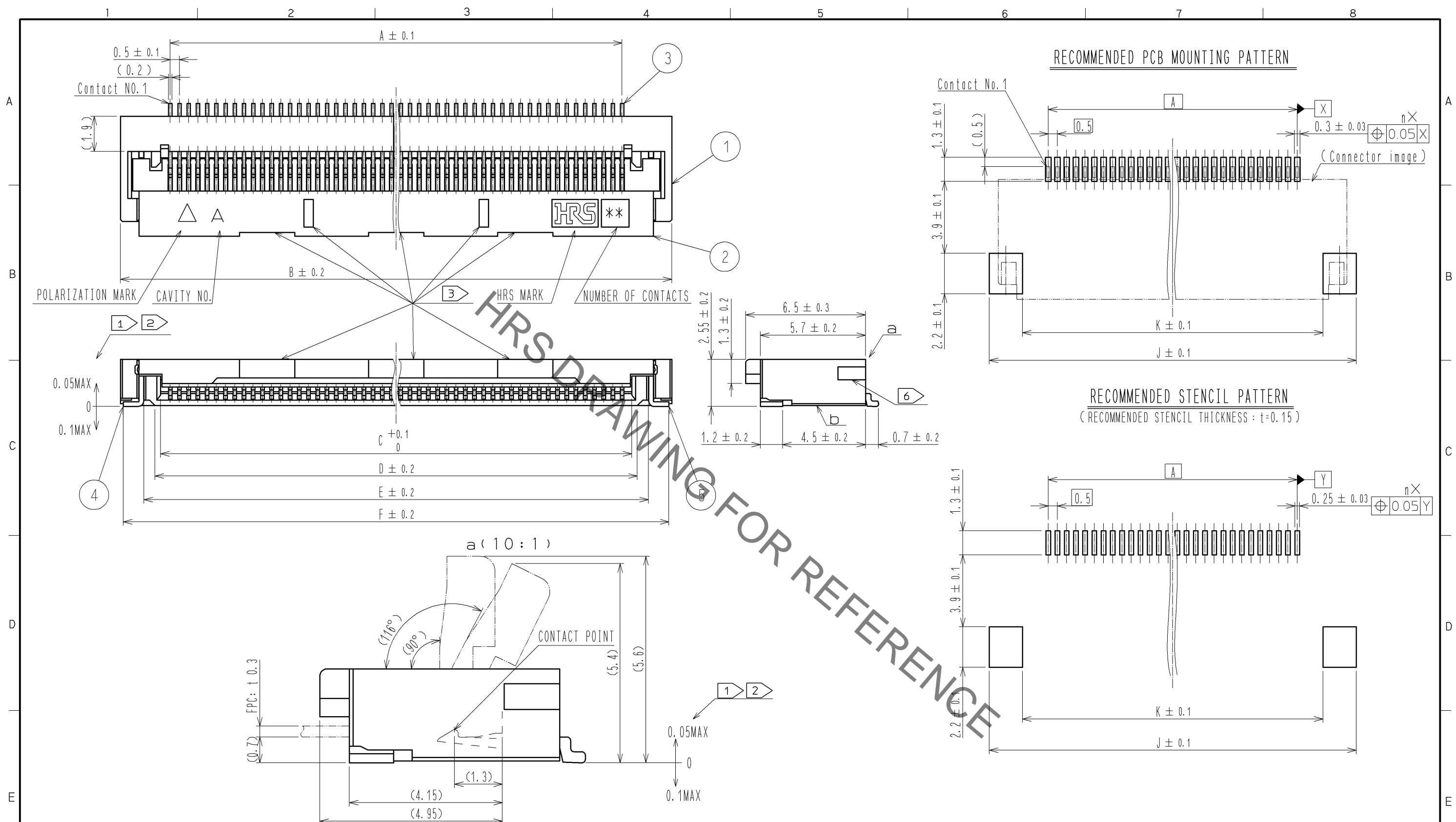

- NOTES
- 1 Lead CO-PLANARITY including reinforced metal fittings shall be 0.1 MAX.
  - 2 Dimension: from reference b.
  - 3 Indicates notches or holes to prevent sink marks. The design and the location are discretionary, depending on the number of contacts.
  - 4. This product satisfies halogen free requirements defined as 900ppm maximum chlorine, 900ppm maximum bromine, and 1500ppm maximum total of chlorine and bromine.
  - 5. 'n' represents the number of contacts.
  - 6 Indicates notches for attachment dust cover.  
FH28 series : without notches.  
FH28D series : with notches.  
There is no difference in performance between FH28 series and FH28D series.

| 5                       | BRASS           | TIN PLATING 1#MMIN OVER NICKEL 1#MMIN     |       |             |                          |                    |         |      |
|-------------------------|-----------------|---|-------|-------------|--------------------------|--------------------|---------|------|
| 4                       | BRASS           | TIN PLATING 1#MMIN OVER NICKEL 1#MMIN     | 9     | (CONNECTOR) |                          |                    |         |      |
| 3                       | PHOSPHOR BRONZE | GOLD PLATING 0.05#MMIN OVER NICKEL 1#MMIN | 8     | POLYSTYRENE |                          |                    |         |      |
| 2                       | LCP             | (BLACK) UL94V-0                           | 7     | POLYESTER   |                          |                    |         |      |
| 1                       | LCP             | (GRAY) UL94V-0                            | 6     | POLYSTYRENE |                          |                    |         |      |
| NO.                     | MATERIAL        | FINISH . REMARKS                          | NO.   | MATERIAL    | FINISH . REMARKS         |                    |         |      |
| UNITS                   | mm              | SCALE                                     | 5 : 1 | COUNT       | DESCRIPTION OF REVISIONS | DESIGNED           | CHECKED | DATE |
| APPROVED : HS. SAKAMOTO |                 | 13. 09. 20                                |       | DRAWING NO. |                          | EDC3-353836-01     |         |      |
| CHECED : HS. SAKAMOTO   |                 | 13. 09. 20                                |       | PART NO.    |                          | FH28-*S-0.5SH(05)  |         |      |
| DESIGNED : RT. IKEDA    |                 | 13. 09. 19                                |       | CODE NO.    |                          | FH28D-*S-0.5SH(05) |         |      |
| DRAWN : RT. IKEDA       |                 | 13. 09. 19                                |       | CL586       |                          |                    |         |      |

Jun.1.2020 Copyright 2020 HIROSE ELECTRIC CO., LTD. All Rights Reserved.  
In case of consideration for using Automotive equipment / device which demand high reliability, kindly contact our sales window correspondents.

RECOMMENDED FPC/FFC (15:1)

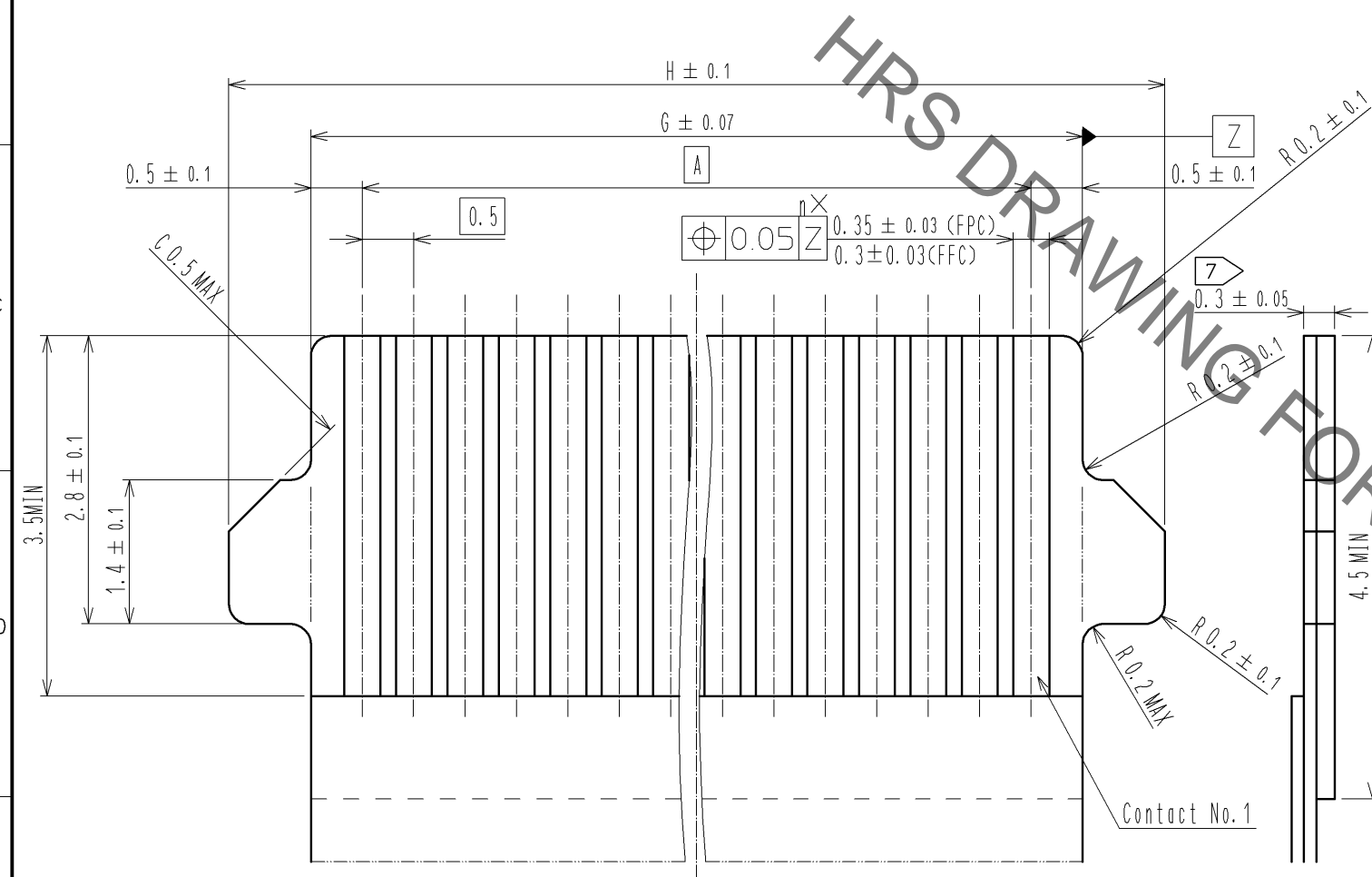

7 Thickness of supporting tape shall be 0.188(7.5mil) MIN.

FPC CONFIGURATION (REFERENCE EXAMPLE) (SCALE:FREE)

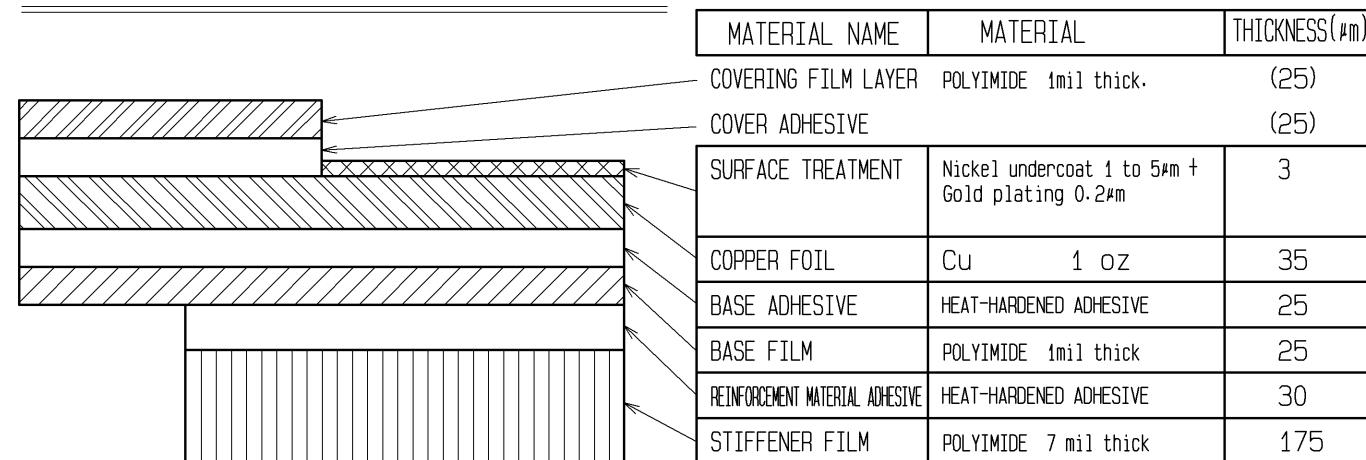

| MATERIAL NAME                   | MATERIAL                                       | THICKNESS(μm) |
|---------------------------------|--|---------------|
| COVERING FILM LAYER             | POLYIMIDE 1mil thick.                          | (25)          |
| COVER ADHESIVE                  |  | (25)          |
| SURFACE TREATMENT               | Nickel undercoat 1 to 5μm + Gold plating 0.2μm | 3             |
| COPPER FOIL                     | Cu 1 oz  | 35            |
| BASE ADHESIVE                   | HEAT-HARDENED ADHESIVE                         | 25            |
| BASE FILM                       | POLYIMIDE 1mil thick                           | 25            |
| REINFORCEMENT MATERIAL ADHESIVE | HEAT-HARDENED ADHESIVE                         | 30            |
| STIFFENER FILM                  | POLYIMIDE 7 mil thick                          | 175           |

FFC CONFIGURATION (REFERENCE EXAMPLE) (SCALE:FREE)

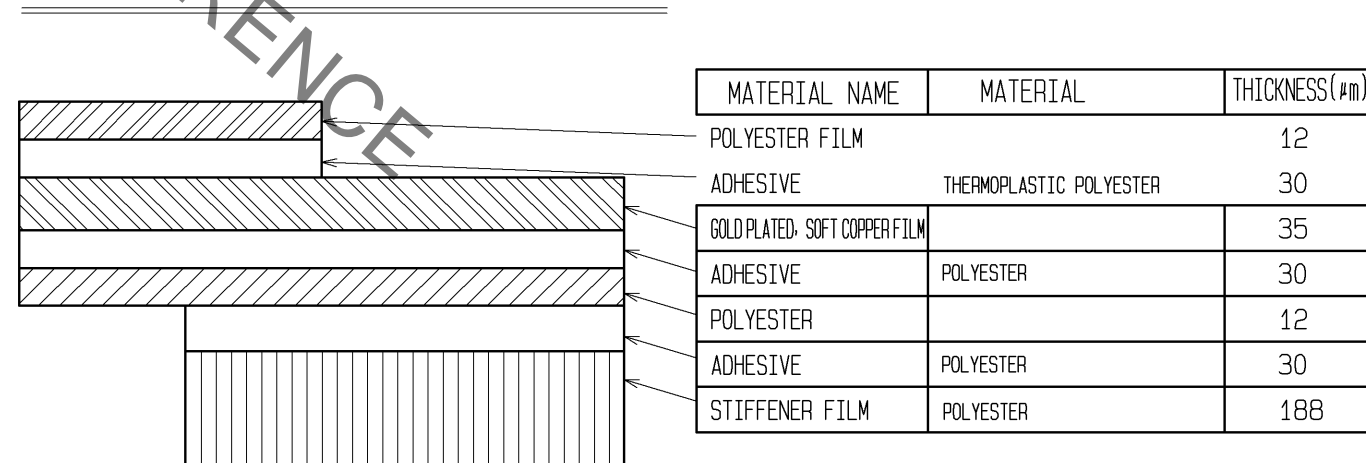

| MATERIAL NAME                | MATERIAL                | THICKNESS(μm) |
|------------------------------|-------------------------|---------------|
| POLYESTER FILM               |                         | 12            |
| ADHESIVE                     | THERMOPLASTIC POLYESTER | 30            |
| GOLD PLATED SOFT COPPER FILM |                         | 35            |
| ADHESIVE                     | POLYESTER               | 30            |
| POLYESTER                    |                         | 12            |
| ADHESIVE                     | POLYESTER               | 30            |
| STIFFENER FILM               | POLYESTER               | 188           |

|            |             |   |
|------------|-------------|---|
| <b>HRS</b> | DRAWING NO. | EDC3-353836-01                          |
|            | PART NO.    | FH28-*S-0.5SH(05)<br>FH28D-*S-0.5SH(05) |
|            | CODE NO.    | CL586                                   |
|            |             | 2/4                                     |

Jun.1.2020 Copyright 2020 HIROSE ELECTRIC CO., LTD. All Rights Reserved.  
 In case of consideration for using Automotive equipment / device which demand high reliability, kindly contact our sales window correspondents.

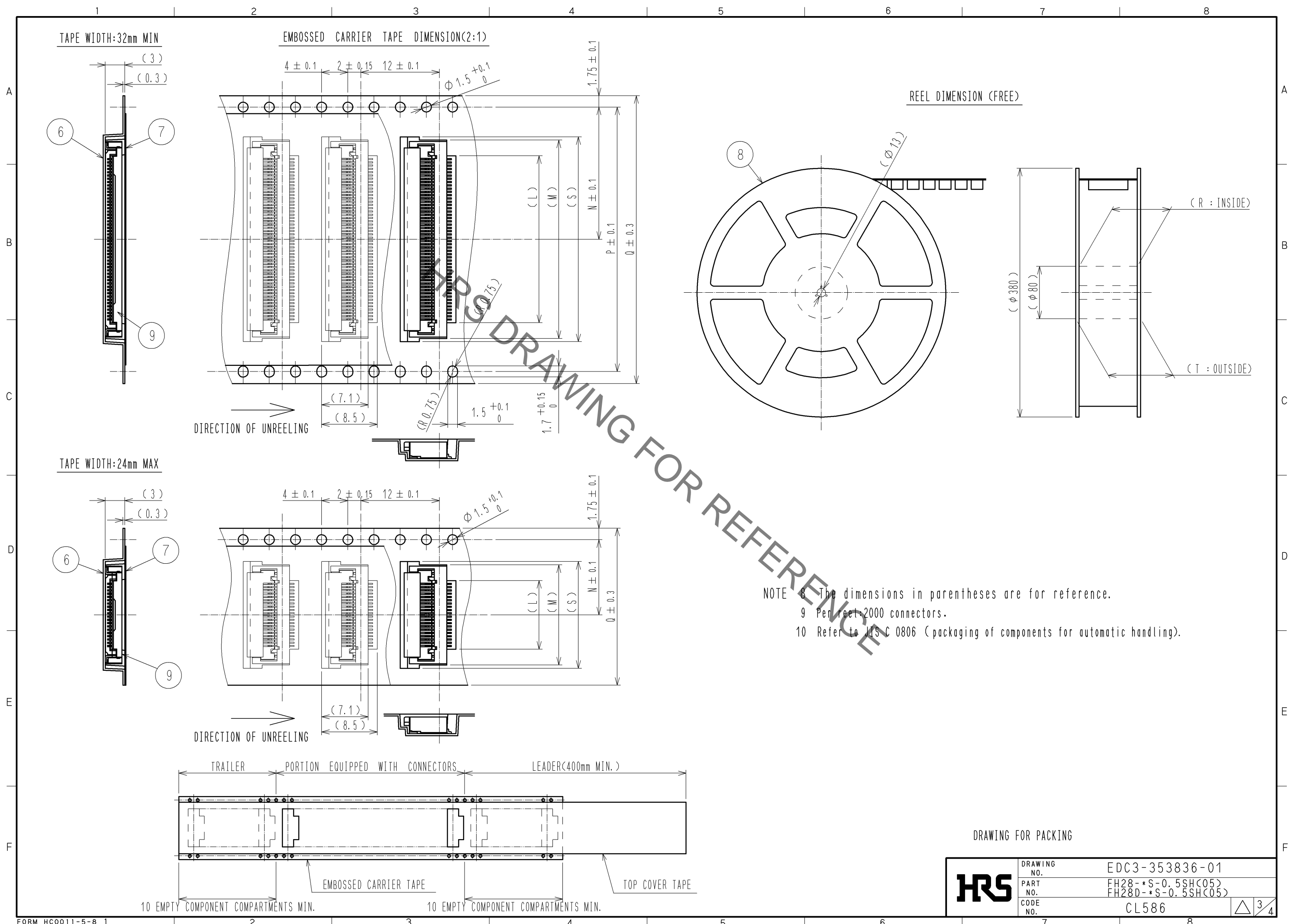

NOTE 8 The dimensions in parentheses are for reference.  
 9 Per JIS C 2000 connectors.  
 10 Refer to JIS C 0806 (packaging of components for automatic handling).

DRAWING FOR PACKING

|            |             |   |
|------------|-------------|---|
| <b>HRS</b> | DRAWING NO. | EDC3-353836-01                          |
|            | PART NO.    | FH28-*S-0.5SH<05><br>FH28D-*S-0.5SH<05> |
|            | CODE NO.    | CL586                                   |
|            | 3/4         |   |

Jun.1.2020 Copyright 2020 HIROSE ELECTRIC CO., LTD. All Rights Reserved.  
In case of consideration for using Automotive equipment / device which demand high reliability, kindly contact our sales window correspondents.

| PART NO.   | CODE NO.        | Number of contact | DIMENSION TABLE OF CONNECTOR, FPC, FFC, LAND PATTERN AND STENCIL PATTERN |      |       |       |       |       |      |      |      |      | DIMENSION TABLE OF DRAWING FOR PACKING |      |      |      |    |      |      |      |
|--|-----------------|-------------------|--|------|-------|-------|-------|-------|------|------|------|------|--|------|------|------|----|------|------|------|
|  |                 |                   | A  | B    | C     | D     | E     | F     | G    | H    | J    | K    | L                                      | M    | N    | P    | Q  | R    | T    | S    |
| FH28 -10S-0.5SH(05)  | CL586-1861-4-05 | 10                | 4.5  | 8.8  | 5.57  | 6.15  | 7.35  | 9.58  | 5.5  | 7.1  | 10.6 | 7    | 5.5                                    | 10.3 | 11.5 | -    | 24 | 25.4 | 29.4 | 11.3 |
| FH28 -15S-0.5SH(05)  | CL586-1868-3-05 | 15                | 7  | 12.4 | 8.07  | 8.65  | 9.85  | 12.08 | 8    | 9.6  | 13.1 | 9.5  | 8                                      | 12.8 | 11.5 | -    | 24 | 25.4 | 29.4 | 13.8 |
| FH28D-20S-0.5SH(05)  | CL586-1823-5-05 | 20                | 9.5  | 14.9 | 10.57 | 11.15 | 12.35 | 14.58 | 10.5 | 12.1 | 15.6 | 12   | 10.5                                   | 15.3 | 11.5 | -    | 24 | 25.4 | 29.4 | 16.3 |
| FH28D-28S-0.5SH(05)  | CL586-1835-4-05 | 28                | 13.5   | 18.9 | 14.57 | 15.15 | 16.35 | 18.58 | 14.5 | 16.1 | 19.6 | 16   | 14.5                                   | 19.3 | 14.2 | 28.4 | 32 | 33.4 | 37.4 | 20.3 |
| FH28D-30S-0.5SH(05)  | CL586-1827-6-05 | 30                | 14.5   | 19.9 | 15.57 | 16.15 | 17.35 | 19.58 | 15.5 | 17.1 | 20.6 | 17   | 15.5                                   | 20.3 | 14.2 | 28.4 | 32 | 33.4 | 37.4 | 21.3 |
| <span style="border: 1px solid black; padding: 0 2px;">11</span> FH28 -40S-0.5SH(07) | CL586-1803-8-07 | 40                | 19.5   | 24.9 | 20.57 | 21.15 | 22.35 | 24.58 | 20.5 | 22.1 | 25.6 | 22   | 20.5                                   | 25.3 | 20.2 | 40.4 | 44 | 45.4 | 49.4 | -    |
| FH28 -45S-0.5SH(05)  | CL586-1848-6-05 | 45                | 22   | 27.4 | 23.07 | 23.65 | 24.85 | 27.08 | 23   | 24.6 | 28.1 | 24.5 | 23                                     | 27.8 | 20.2 | 40.4 | 44 | 45.4 | 49.4 | 28.8 |
| FH28 -50S-0.5SH(05)  | CL586-1801-2-05 | 50                | 24.5   | 29.9 | 25.57 | 26.15 | 27.35 | 29.58 | 25.5 | 27.1 | 30.6 | 27   | 25.5                                   | 30.3 | 20.2 | 40.4 | 44 | 45.4 | 49.4 | -    |
| FH28 -55S-0.5SH(05)  | CL586-1800-0-05 | 55                | 27   | 32.4 | 28.07 | 28.65 | 29.85 | 32.08 | 28   | 29.6 | 33.1 | 29.5 | 28                                     | 32.8 | 20.2 | 40.4 | 44 | 45.4 | 49.4 | -    |
| FH28 -60S-0.5SH(05)  | CL586-1811-6-05 | 60                | 29.5   | 34.9 | 30.57 | 31.15 | 32.35 | 34.58 | 30.5 | 32.1 | 35.6 | 32   | 30.5                                   | 35.3 | 26.2 | 52.4 | 56 | 57.4 | 61.4 | -    |
| FH28D-64S-0.5SH(05)  | CL586-1813-1-05 | 64                | 31.5   | 36.9 | 32.57 | 33.15 | 34.35 | 36.58 | 32.5 | 34.1 | 37.6 | 34   | 32.5                                   | 37.3 | 26.2 | 52.4 | 56 | 57.4 | 61.4 | -    |
| FH28D-68S-0.5SH(05)  | CL586-1819-8-05 | 68                | 33.5   | 38.9 | 34.57 | 35.15 | 36.35 | 38.58 | 34.5 | 36.1 | 39.6 | 36   | 34.5                                   | 39.3 | 26.2 | 52.4 | 56 | 57.4 | 61.4 | -    |
| FH28D-74S-0.5SH(05)  | CL586-1828-9-05 | 74                | 36.5   | 41.9 | 37.57 | 38.15 | 39.35 | 41.58 | 37.5 | 39.1 | 42.6 | 39   | 37.5                                   | 42.3 | 26.2 | 52.4 | 56 | 57.4 | 61.4 | 43.3 |

11 : The specification of (07) is applied to FH28-40S-0.5SH.

|            |             |   |
|------------|-------------|---|
| <b>HRS</b> | DRAWING NO. | EDC3-353836-01                          |
|            | PART NO.    | FH28-*S-0.5SH(05)<br>FH28D-*S-0.5SH(05) |
|            | CODE NO.    | CL586                                   |
|            | 4/4         |   |