

Click to
ORDER
samples

AMEL30-277HAVZ



The AMEL30-277HAVZ series is an efficient 30W AC-DC power supply module. Offering a commercial input voltage range of 85-305VAC, output voltage ranges from 3.3-48V, low power consumption up to 0.1W, high efficiency, high reliability and safer isolation.

This new series offers great operating temperatures, from -40°C to 85°C with full power up to 50°C and features an isolation of 4200VAC with OVCIII rating for improved reliability and system safety. Furthermore, a high MTBF of 500,000h, output short circuit protection (OSCP), output over-current protection (OCP) and an output over-voltage protection (OVP) come standard with the series.

The AMEL30-277HAVZ is great for grid power, industrial instrumentation and controls, communication, and civil applications.

Features



- Universal Input: 85 - 305VAC/120 - 430VDC
- Operating Temp: -40 °C to +85 °C
- High isolation voltage: 4200VAC
- Low ripple & noise, 150mV(p-p), max.
- Output short circuit, over-current, over-voltage protection
- Low no-load power consumption of 0.1W
- Efficiency up to 90%
- Certified : EN/UL62368-1, EN61558-1:2019, EN61558-2-16:2009+A1:2013
- Designed to meet : IEC62368-1, EN60335-1

Summary

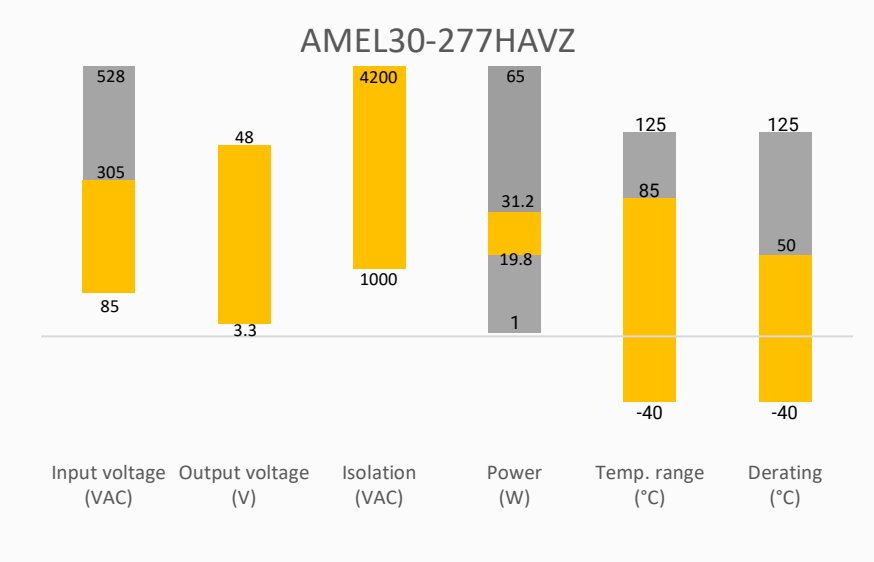

Training



Product Training Video
(click to open)

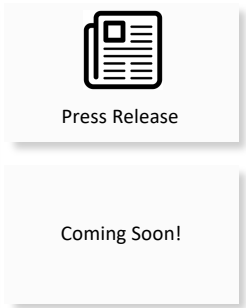

Application Notes

Applications



Power Grid Industrial Telecom

Models & Specifications

Single Output

Model	Input Voltage (VAC/Hz)	Input Voltage (VDC)	Max Output wattage (W)	Output Voltage (V)	Output Current max (A)	Maximum capacitive load (μ F)	Efficiency @ 230VAC Typ. (%)
AMEL30-3S277HAVZ	85-305/47-440	120-430	19.8	3.3	6	6600	85
AMEL30-5S277HAVZ	85-305/47-440	120-430	30	5	6	6600	86
AMEL30-9S277HAVZ	85-305/47-440	120-430	30.6	9	3.4	4400	88
AMEL30-12S277HAVZ	85-305/47-440	120-430	30	12	2.5	4400	90
AMEL30-15S277HAVZ	85-305/47-440	120-430	30	15	2	3300	90
AMEL30-24S277HAVZ	85-305/47-440	120-430	31.2	24	1.3	1000	88
AMEL30-48S277HAVZ	85-305/47-440	120-430	30.2	48	0.63	470	90

Note: Use suffix "ST" for chassis and suffix "STD" for DIN-Rail mounting (ex. AMEL30-3S277HAVZ -ST is chassis mounting and AMEL30-3S277HAVZ -STD is DIN-Rail mounting version).

Note: Note: Add suffix "-B" for single unit packaging or "-60" for volume packaging (ex. AMEL30-3S277HAVZ-B is single unit packaging and AMEL30-3S277HAVZ-60 is volume packaging).

Note: Packaging information is not printed on the product label and is only used for ordering the product.

Input Specifications

Parameters	Conditions	Typical	Maximum	Units
Input current	115VAC		750	mA
	230VAC		500	mA
Inrush current	115VAC	25		A
	230VAC	50		A
Leakage	277VAC, 50Hz		0.1	mA RMS
Built-in Fuse	2A/300V, Slow blow			

Output Specifications

Parameters	Conditions	Typical	Maximum	Units
Voltage accuracy	3.3V output model	± 3		%
	Others	± 2		
Line regulation	Full load	± 0.5		%
Load regulation	0 to 100% load	3.3V output	± 2	%
		5V output	± 1.5	
		Others	± 1	
Ripple & Noise*	20MHz bandwidth	3.3V/5V/9V/12V/15V	100	mV p-p
		Others	100	
Hold up time	115VAC	10		ms
	230VAC	50		ms

* Ripple and Noise are measured at 20MHz bandwidth with a 10 μ F electrolytic capacitor and a 1 μ F ceramic capacitor. Please refer to the application note for specific details.

Isolation Specification				
Parameters	Conditions	Typical	Maximum	Units
Tested I/O voltage	60 sec, leakage ≤ 5mA	4200		VAC
Resistance	500VDC	>100		MΩ

General Specifications				
Parameters	Conditions	Typical	Maximum	Units
Protection class	Class II			
Overvoltage category	OVC III			
Over current protection	Auto recovery	≥ 110		% of Iout
Over voltage protection	3.3Vout, voltage clamp, hiccup		6.3	VDC
	5V, 9V, 12Vout, voltage clamp, hiccup		16	VDC
	15Vout, voltage clamp, hiccup		25	VDC
	24Vout, voltage clamp, hiccup		35	VDC
	48Vout, voltage clamp, hiccup		60	VDC
Short circuit protection	Hiccup, Continuous, Auto recovery			
Switching Frequency		65		KHz
Operating altitude			5000	m
Operating temperature	See derating graph	-40 to +85		°C
Storage temperature		-40 to +85		°C
Wave soldering temperature	Duration 5 - 10s	260 ± 5		°C
Manual soldering temperature	Duration 3 - 5s	360 ± 10		°C
No-load power consumption	230VAC, 48Vout	0.15	0.2	W
	230VAC, others	0.1	0.12	W
Power Derating	-40 °C to -25 °C, 85VAC to 115VAC, 5V output	2.67		%/°C
	-40 °C to -25 °C, 85VAC to 115VAC, Others	1.33		%/°C
	+50 °C to +70 °C	2.5		%/°C
	+70 °C to +85 °C	0.67		%/°C
	85VAC to 100VAC	1.33		%/VAC
	277VAC to 305VAC	0.72		%/VAC
	2000 - 5000m	6.7		%/km
Temperature coefficient		±0.02		%/°C
Cooling	Free air convection			
Humidity	Non-condensing		95	% RH
Case material	Plastic (flammability to UL 94V-0)			
Weight	PCB mountable models	100		g
	With optional -ST mounting plate	147		g
	With optional -STD mounting plate	190		g
Dimensions (L x W x H)	PCB mountable models	2.74 x 1.54 x 0.95 inches (69.50 x 39.00 x 24.00 mm)		
	With optional -ST mounting plate	3.78 x 2.13 x 1.28 inches (96.10 x 54.00 x 32.50 mm)		
	With optional -STD mounting plate	3.78 x 2.13 x 1.46 inches (96.10 x 54.00 x 37.10 mm)		
MTBF	> 500 000 hrs (MIL-HDBK -217F, t=+25°C)			
NOTE: All specifications in this datasheet are measured at an ambient temperature of 25°C, humidity<75%, nominal input voltage and at rated output load unless otherwise specified.				

Safety Specifications		
Parameters		
Agency approvals	cULus UL62368-1, EN62368-1:2020+A11:2020, EN61558-1:2019, EN61558-2-16:2009+A1:2013	
Standards	Designed to meet IEC 62368-1, EN60335-1	
	EMC - Conducted and radiated emission	CISPR32 / EN55032, class B EN55014-1
	Electrostatic Discharge Immunity	IEC 61000-4-2 Contact $\pm 8\text{KV}$, Air $\pm 15\text{KV}$, Criteria A EN55014-2, Criteria A
	RF, Electromagnetic Field Immunity	IEC 61000-4-3 10V/m, Criteria A EN55014-2, Criteria A
	Electrical Fast Transient/Burst Immunity	IEC 61000-4-4 $\pm 2\text{KV}$, Criteria A IEC 61000-4-4 $\pm 4\text{KV}$, Criteria A with the recommended EMC circuit EN55014-2, Criteria A
	Surge Immunity	IEC 61000-4-5 L-L $\pm 2\text{KV}$, Criteria A IEC 61000-4-5 L-L $\pm 2\text{KV}$, L-GND $\pm 2\text{KV}$, Criteria A with the recommended EMC circuit EN55014-2, Criteria A
	RF, Conducted Disturbance Immunity	IEC 61000-4-6 10Vr.m.s, Criteria A EN55014-2, Criteria A
	Voltage dips, Short Interruptions Immunity	IEC 61000-4-11 0%, 70%, Criteria B EN55014-2, Criteria B

Derating

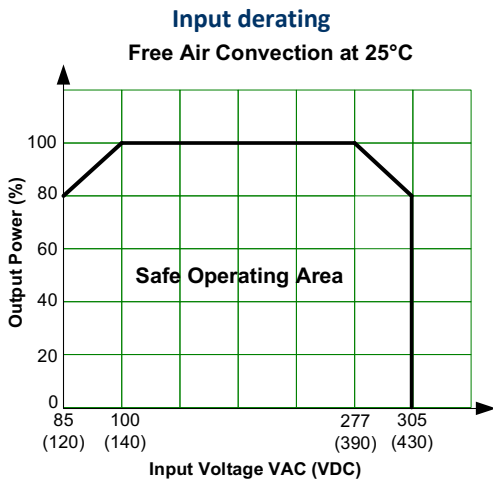
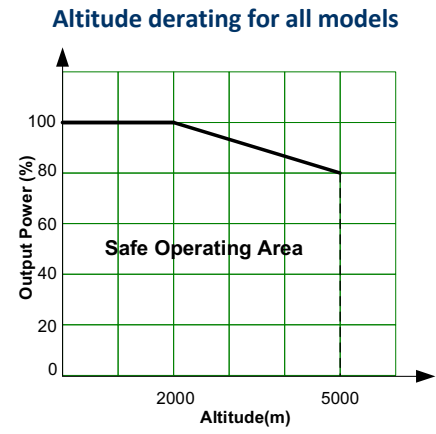
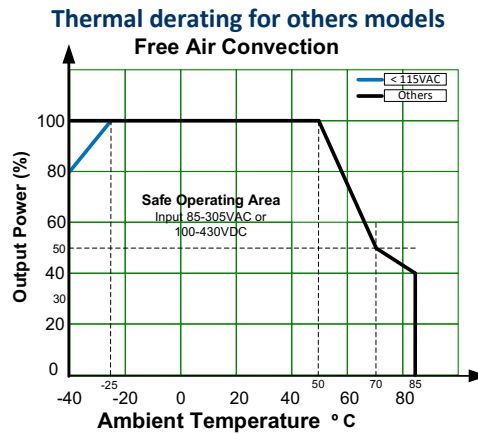
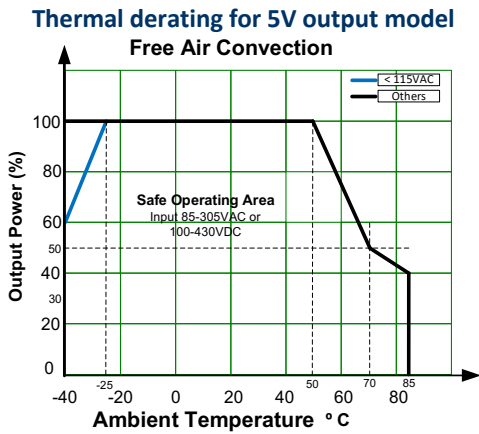

Efficiency vs input voltage

Efficiency vs input voltage (Full load)

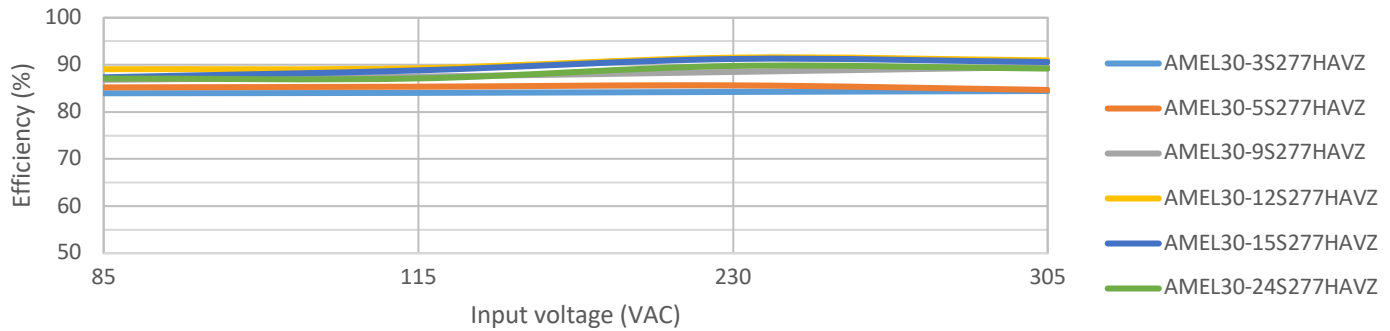

Typical Application Circuit

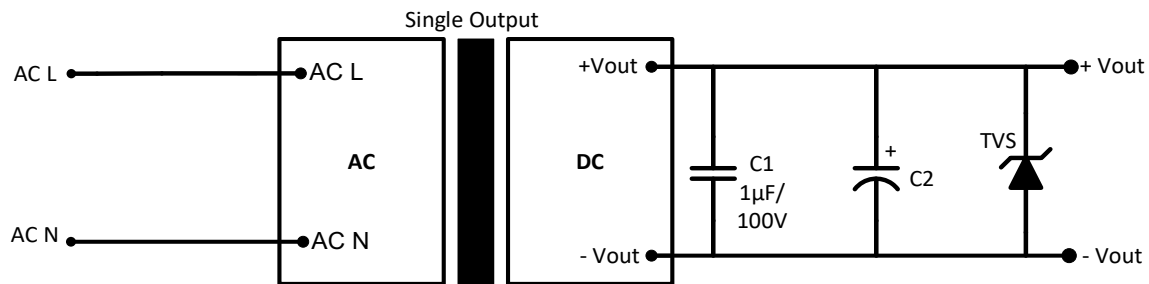

Model	C2	TVS
3.3, 5Vout	10µF/50V	7V
9Vout	10µF/50V	12V
12, 15Vout	10µF/50V	20V
24Vout	10µF/50V	30V
48Vout	10µF/63V	60V

For filtering components:

The C2 capacitor is recommended to use electrolytic type with high frequency and low ESR rating. The C1 capacitor is recommended to use ceramic type for filtering high-frequency noise.

Recommended EMC Circuit 1

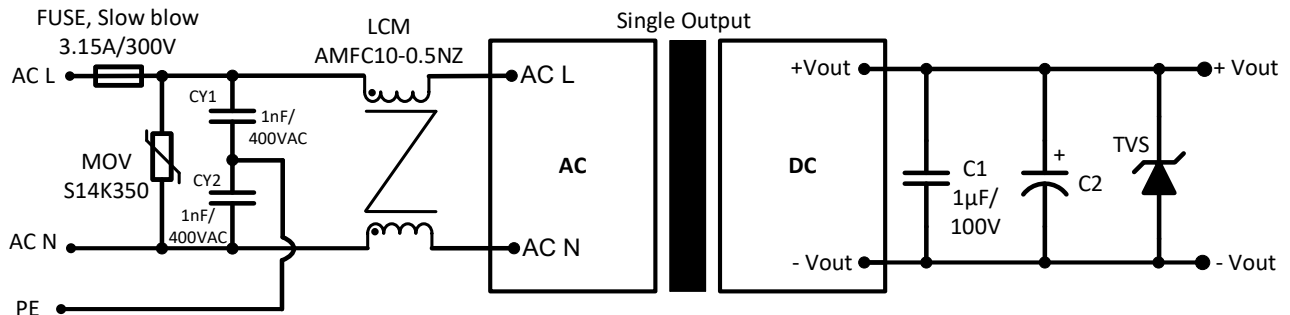

Recommended EMC Circuit 2

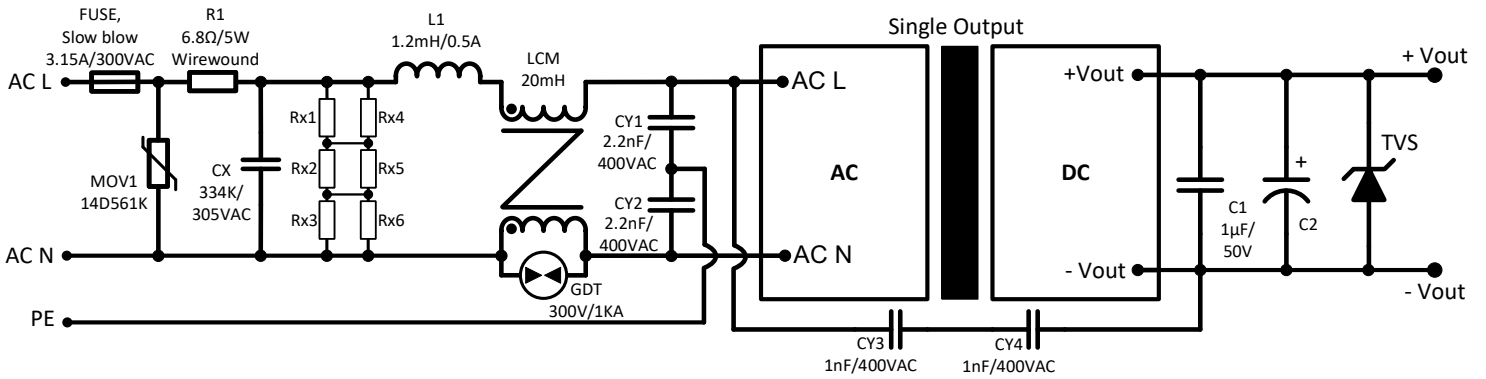

Rx1, Rx2, Rx3, Rx4, Rx5, Rx6
1.5MΩ/150VDC

Dimensions

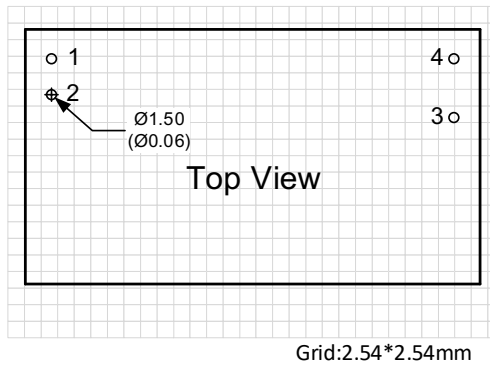
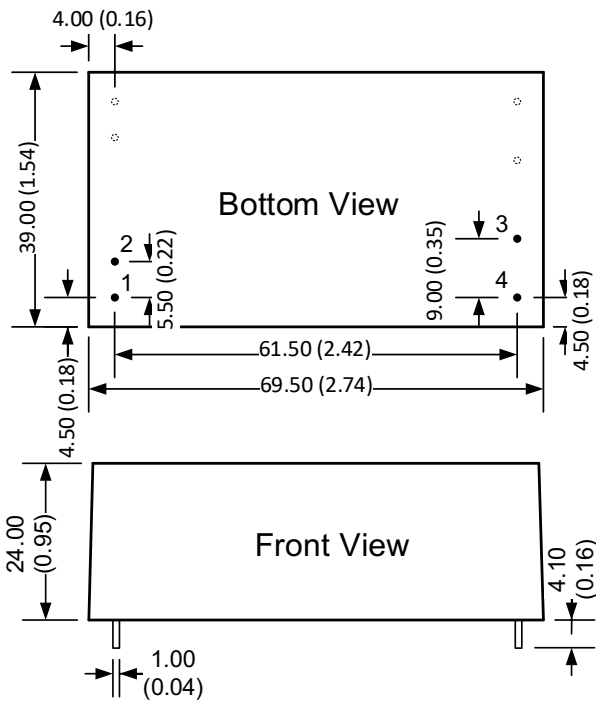

Pin Output Specifications	
Pin	Function
1	AC Input (L)
2	AC Input (N)
3	+V Output
4	-V Output

Dimensions mm (inch).
Pin diameter tolerance ± 0.1 (± 0.004)
General tolerance ± 0.5 (± 0.02)

Dimensions with ST Optional

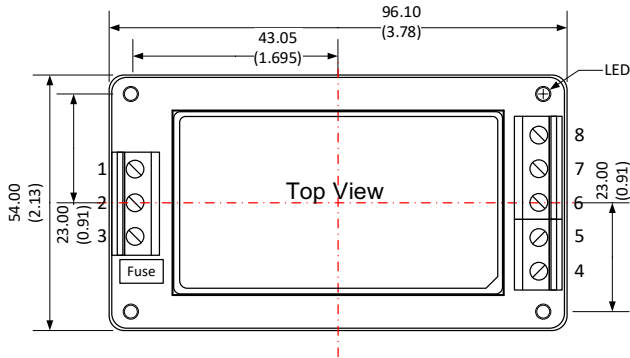

Pin Output Specifications	
Pin	Function
1	NC
2	AC Input (L)
3	AC Input (N)
4	+V Output
5	NC
6	NC
7	NC
8	-V Output

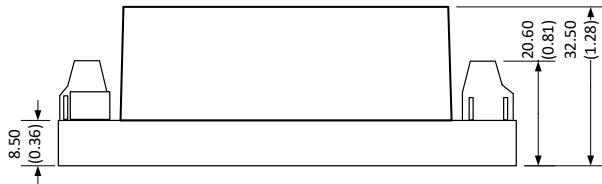

Note:
Unit: mm(inch)
Wire range : 24-12 AWG
Tightening torque : Max 0.4 N.m
General tolerance ± 1.00 : (± 0.04)

Dimensions with STD Optional

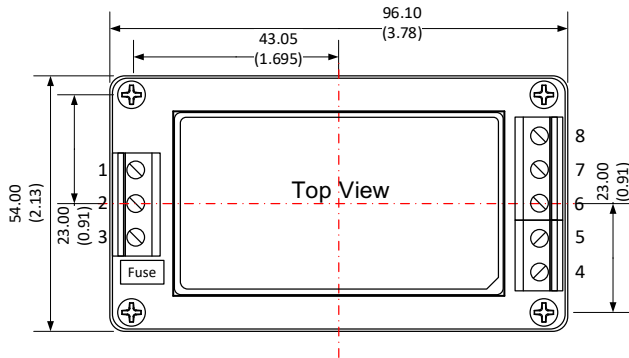

Pin Output Specifications	
Pin	Function
1	NC
2	AC Input (L)
3	AC Input (N)
4	+V Output
5	NC
6	NC
7	NC
8	-V Output

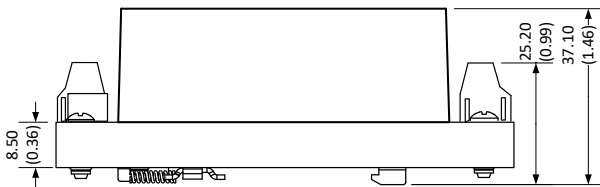

Note:
Unit: mm(inch)
Wire range : 24-12 AWG
Mounting rail: TS35
Tightening torque : Max 0.4 N.m
General tolerance ± 1.00 : (± 0.04)
Mounting rail must be grounded.

NOTE: **1.** Datasheets are updated as needed and as such, specifications are subject to change without notice. Once printed or downloaded, datasheets are no longer controlled by Aimtec; refer to www.aimtec.com for the most current product specifications. **2.** Product labels shown, including safety agency certifications on labels, may vary based on the date manufactured. **3.** Mechanical drawings and specifications are for reference only. **4.** All specifications are measured at an ambient temperature of 25°C, humidity < 75%, nominal input voltage and at rated output load unless otherwise specified. **5.** Aimtec may not have conducted destructive testing or chemical analysis on all internal components and chemicals at the time of publishing this document. CAS numbers and other limited information are considered proprietary and may not be available for release. **6.** This product is not designed for use in critical life support systems, equipment used in hazardous environments, nuclear control systems or other such applications which necessitate specific safety and regulatory standards other than the ones listed in this datasheet. **7.** Warranty is in accordance with Aimtec's standard Terms of Sale available at www.aimtec.com.