



FEATURES:

- Input: 85-305VAC, 47-440Hz or 70-430VDC
- Operating temperature -40°C to +85°C
- Low power consumption $\leq 0.25W$
- Continuous short circuit protection
- I/O Isolation 3000VAC
- Ultra slim open frame SIP
- Over current protection
- Class II power supply

Models
Single output



Model	Input Voltage (VAC/Hz)	Input Voltage (VDC)	Full power temperature range (°C)	Output Voltage (V)	Output Current max (mA)	Maximum capacitive load (μF)	Efficiency (%)
AMEOF3-3.3SJZ	85-305/47-63	70-430	-20 to +70	3.3	600	820	65
AMEOF3-5SJZ	85-305/47-63	70-430	-20 to +70	5	600	680	70
AMEOF3-9SJZ	85-305/47-63	70-430	-20 to +70	9	333	470	73
AMEOF3-12SJZ	85-305/47-63	70-430	-20 to +70	12	250	470	74
AMEOF3-15SJZ	85-305/47-63	70-430	-20 to +70	15	200	330	75
AMEOF3-24SJZ	85-305/47-63	70-430	-20 to +70	24	125	100	77
AMEOF3-3.3SLJZ	85-305/47-63	70-430	-20 to +70	3.3	600	820	65
AMEOF3-5SLJZ	85-305/47-63	70-430	-20 to +70	5	600	680	70
AMEOF3-9SLJZ	85-305/47-63	70-430	-20 to +70	9	333	470	73
AMEOF3-12SLJZ	85-305/47-63	70-430	-20 to +70	12	250	470	74
AMEOF3-15SLJZ	85-305/47-63	70-430	-20 to +70	15	200	330	75
AMEOF3-24SLJZ	85-305/47-63	70-430	-20 to +70	24	125	100	77

NOTE: All specifications in this datasheet are measured at an ambient temperature of 25°C, humidity<75%, nominal input voltage and at rated output load unless otherwise specified.

Input Specifications

Parameters	Conditions	Typical	Maximum	Units
Current	115VAC		120	mA
	277VAC		60	mA
Inrush current <2ms	115VAC	13		A
	277VAC	23		A
External fuse	Recommended slow blow type	1		A
Input dissipation	No Load, 230VAC	0.15	0.25	W
Input filter	Recommended external π (Pi) filter			

Output Specifications

Parameters	Conditions	Typical	Maximum	Units
Voltage accuracy	Full load, 3.3V output		± 6	%
	Full load, others		± 5	%
Line regulation	Full load, 3.3V output	± 2.5		%
	Full load, others	± 1.5		%
Load regulation	10% - 100% load, 24V	± 6		%
	10% - 100% load, others	± 3		%
Ripple & Noise	20MHz Bandwidth	80	150	mV p-p
Minimum load		10		% of Max

Isolation Specifications

Parameters	Conditions	Typical	Rated	Units
Tested I/O voltage	60 sec		3000	VAC

General Specifications

Parameters	Conditions	Typical	Maximum	Units
Switching frequency			65	KHz
Over current protection	Auto-recovery	≥ 110	500	% of I out
Short circuit protection	Continuous			

Short circuit restart	Auto-recovery		
Operating temperature	See derating curve	-40 to +85	°C
Power derating	-40°C to -20°C (85-110VAC)	2	% / °C
	70°C to 85°C	2.67	% / °C
	85 to 110VAC	0.8	% / VAC
	277 to 305VAC	1.1	% / VAC
Storage temperature		-40 to +105	°C
Temperature coefficient		±0.15	% / °C
Cooling	Free air convection		
Humidity		85	% RH
Weight		6	g
Dimensions (L x W x H)	1.38 x 0.71 x 0.43 inches 35 x 18 x 11 mm		
MTBF	>300,000 hours (MIL-HDBK -217F, Ground Benign, t=+25°C)		

Safety Specifications

Parameters

Agency approvals	UL 60950-1	
Standards	Design to meet EN60335 (With the EN60335 recommended circuit)	
	EMC - Conducted and radiated emission	CISPR32 / EN55032 Class A, (With typical application circuit, EMI Class A circuit) CISPR32 / EN55032 Class B, (With EMI Class B circuit)
	Electrostatic Discharge Immunity	IEC 61000-4-2 Contact ±4KV, Criteria B
	RF, Electromagnetic Field Immunity	IEC 61000-4-3 10V/m, Criteria A
	Electrical Fast Transient/Burst Immunity	IEC 61000-4-4 ±2KV, Criteria B (With typical application circuit, EMS Class III circuit) IEC 61000-4-4 ±4KV, Criteria B (With EMS Class IV circuit)
	Surge Immunity	IEC 61000-4-5 L-L ±1KV, Criteria B (with typical application circuit, EMS Class III and EMI Class A circuit)
		IEC 61000-4-5 L-L ±2KV, Criteria B (with EMS Class IV and EMI Class A circuit)
		IEC 61000-4-5 L-L ±1KV, L-G ±2KV, Criteria B (with EMS Class III and EMI Class B circuit) IEC 61000-4-5 L-L ±2KV, L-G ±4KV, Criteria B (with EMS Class IV and EMI Class B circuit)
	RF, Conducted Disturbance Immunity	IEC 61000-4-6 10Vr.m.s, Criteria A
	Voltage dips, Short Interruptions Immunity	IEC 61000-4-11 0%, 70%, Criteria B

Dimensions

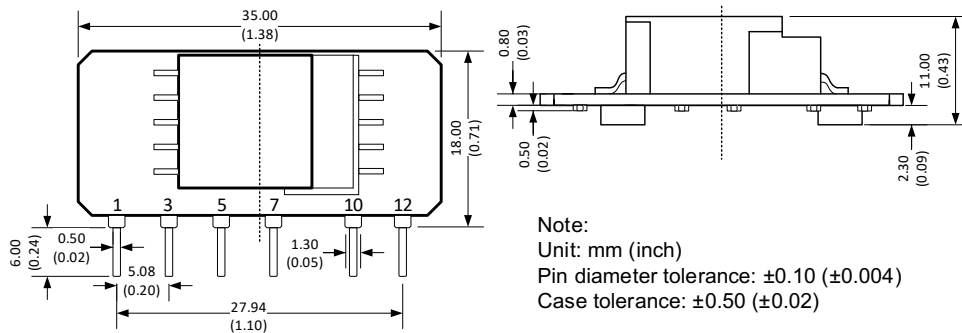

Pin	Single
1	AC N
3	AC L
5	+V sc
7	-V sc
10	-V Output
12	+V Output

L Model Dimensions

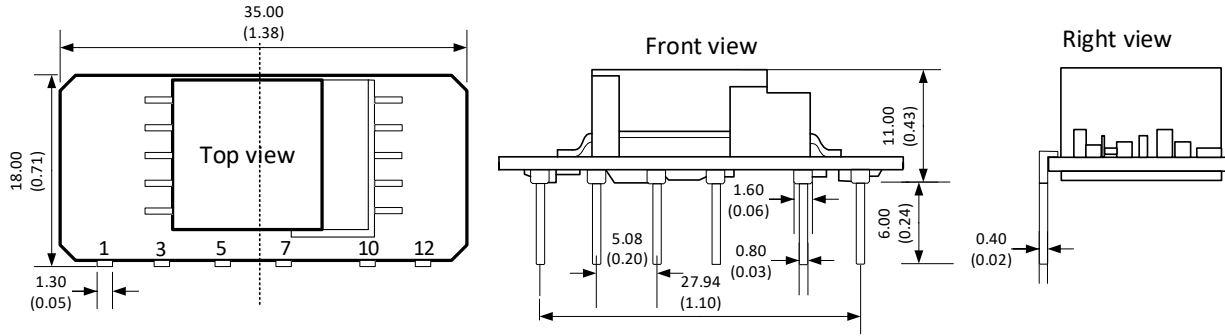

Note:
Unit: mm (inch)
Pin diameter tolerance: ± 0.10 (± 0.004)
Case tolerance: ± 0.50 (± 0.02)

- Note:
1. Capacitor between pin5 and pin7 is necessary.
 2. External circuit on the output side is necessary. Please refer to the recommended circuit.
 3. It is needed to have distance ≥ 6.4 mm for safety between external components in primary circuit and secondary circuit.
 4. The layout of the device is for reference only, please refer to the actual product.

Derating

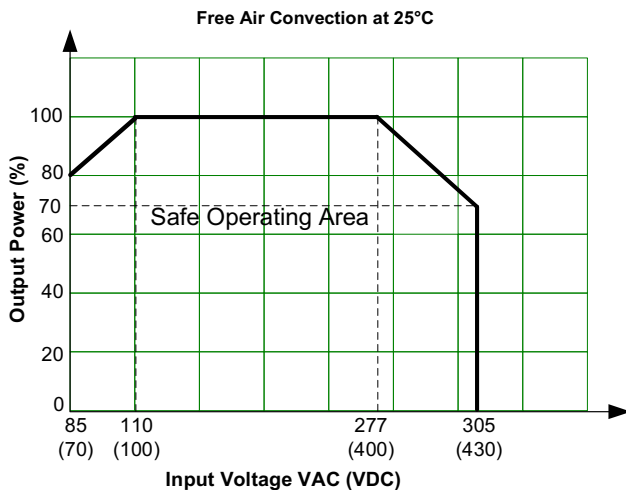
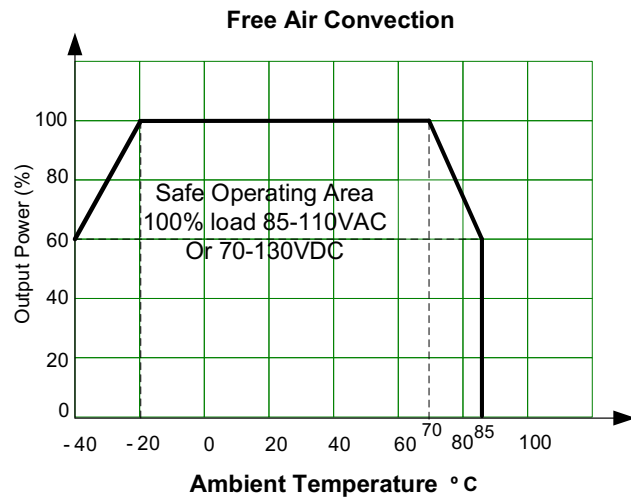
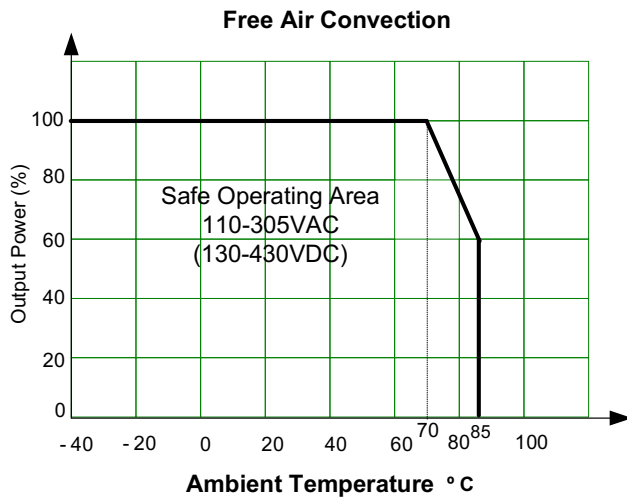

Recommended EMC external circuit

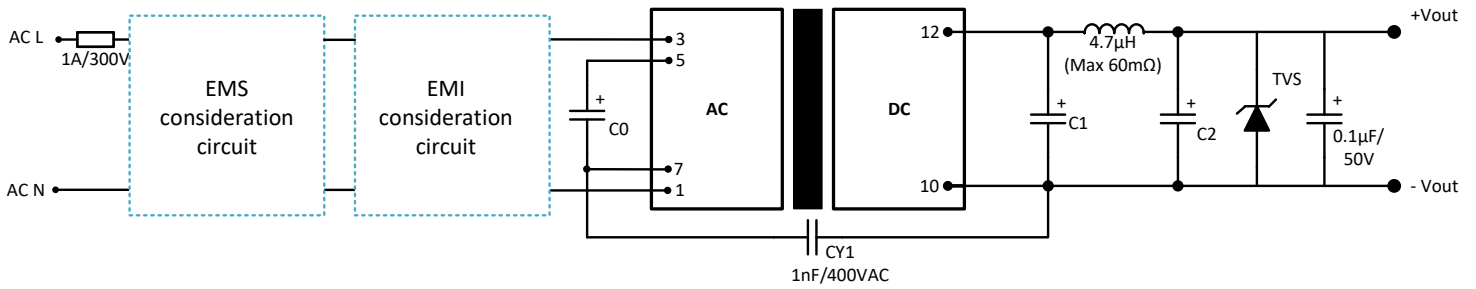

A suppressor diode (TVS) with 1.2 times of the output voltage rating is recommended.

Model	C0	C1	C2
3.3 VDC output		270µF/16V (Solid capacitor)	120µF/25V
5 VDC output	10µF/450V	270µF/16V (Solid capacitor)	68µF/35V
9 VDC output	(-20°C to +85°C)	270µF/16V (Solid capacitor)	68µF/35V
12 VDC output	22µF/450V	270µF/16V (Solid capacitor)	68µF/35V
15 VDC output	(-40°C to +85°C)	470µF/35V	47µF/35V
24 VDC output		220µF/35V	47µF/35V

EMI & EMS Recommended Circuit

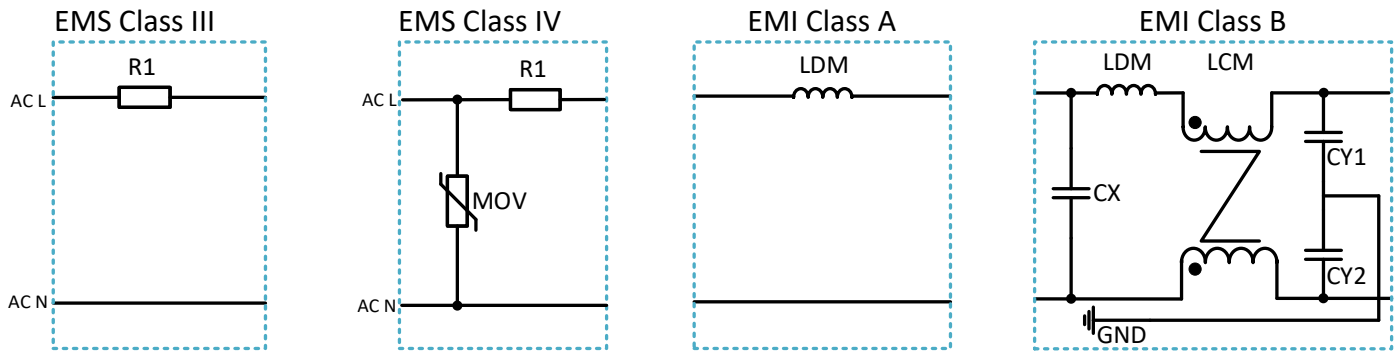

Component	EMS		EMI	
	Class III	Class IV	CLASS A	CLASS B
MOV	-	S14K350	-	-
R1	12Ω/3W	12Ω/3W	-	-
CX	-	-	-	0.1µF/310VAC
CY1	-	-	-	0.56nF/400VAC
CY2	-	-	-	0.56nF/400VAC
LCM	-	-	-	3.5mH
LDM	-	-	4.7mH	0.33mH
FUSE	1A/300V	2A/300V	1A/300V	1A/300V

Typical application circuit

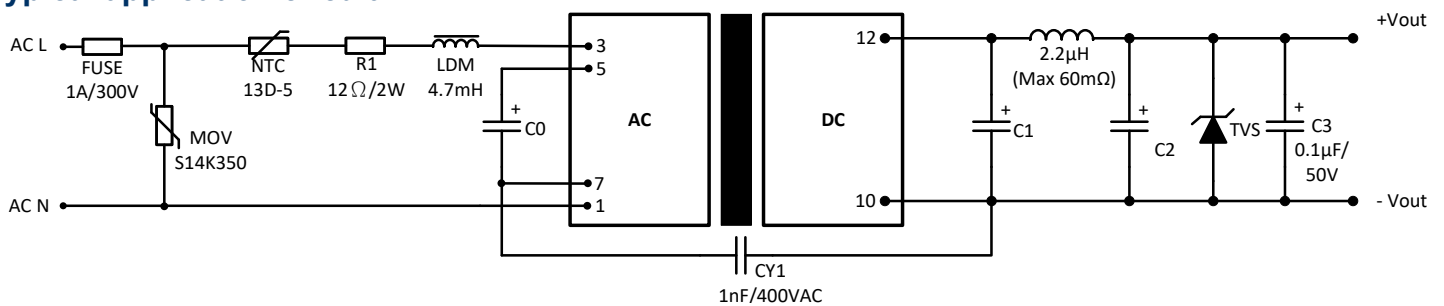

Recommended EMC circuit for EN60335

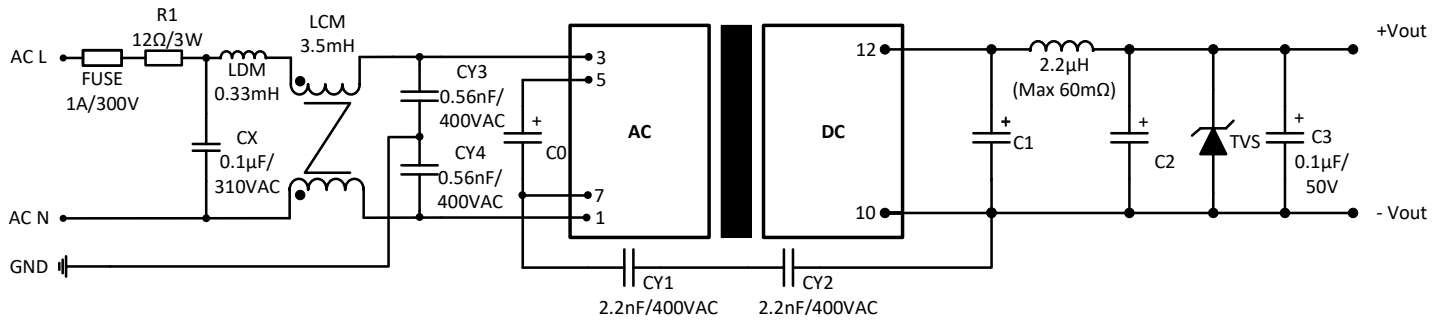

Recommended EMC circuit for EMS Class IV, EMI Class B

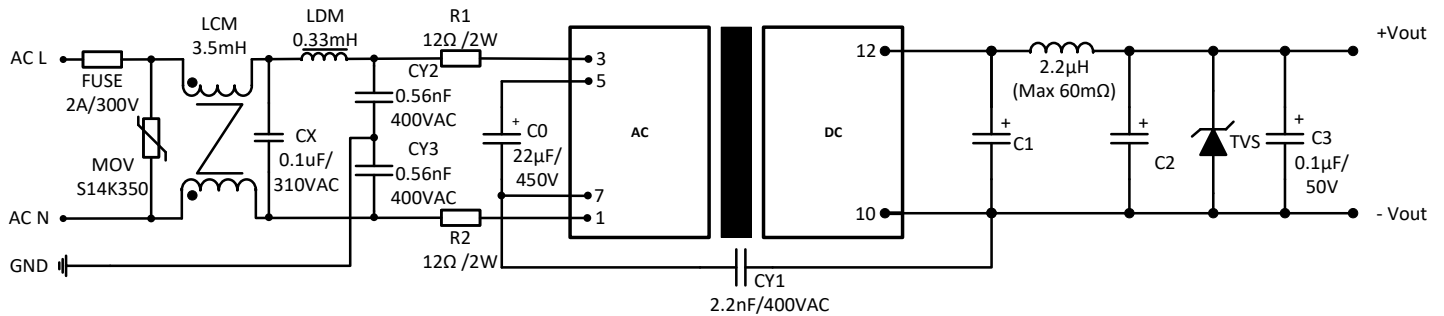
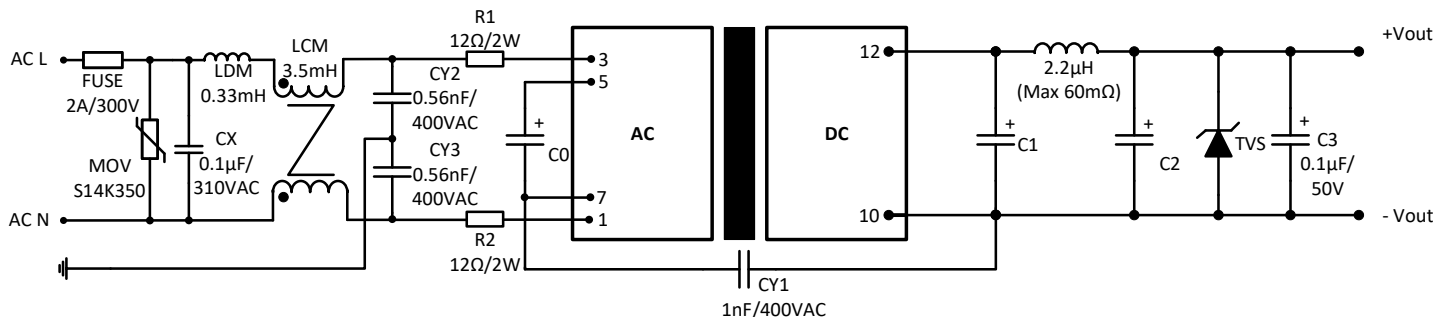

NOTE: 1. Datasheets are updated as needed and as such, specifications are subject to change without notice. Once printed or downloaded, datasheets are no longer controlled by Aimtec; refer to www.aimtec.com for the most current product specifications. 2. Product labels shown, including safety agency certifications on labels, may vary based on the date manufactured. 3. Mechanical drawings and specifications are for reference only. 4. All specifications are measured at an ambient temperature of 25°C, humidity < 75%, nominal input voltage and at rated output load unless otherwise specified. 5. Aimtec may not have conducted destructive testing or chemical analysis on all internal components and chemicals at the time of publishing this document. CAS numbers and other limited information are considered proprietary and may not be available for release. 6. This product is not designed for use in critical life support systems, equipment used in hazardous environments, nuclear control systems or other such applications which necessitate specific safety and regulatory standards other than the ones listed in this datasheet. 7. Warranty is in accordance with Aimtec's standard Terms of Sale available at www.aimtec.com.