

Jul.1.2020 Copyright 2020 HIROSE ELECTRIC CO., LTD. All Rights Reserved.  
In case of consideration for using Automotive equipment / device which demand high reliability, kindly contact our sales window correspondents.

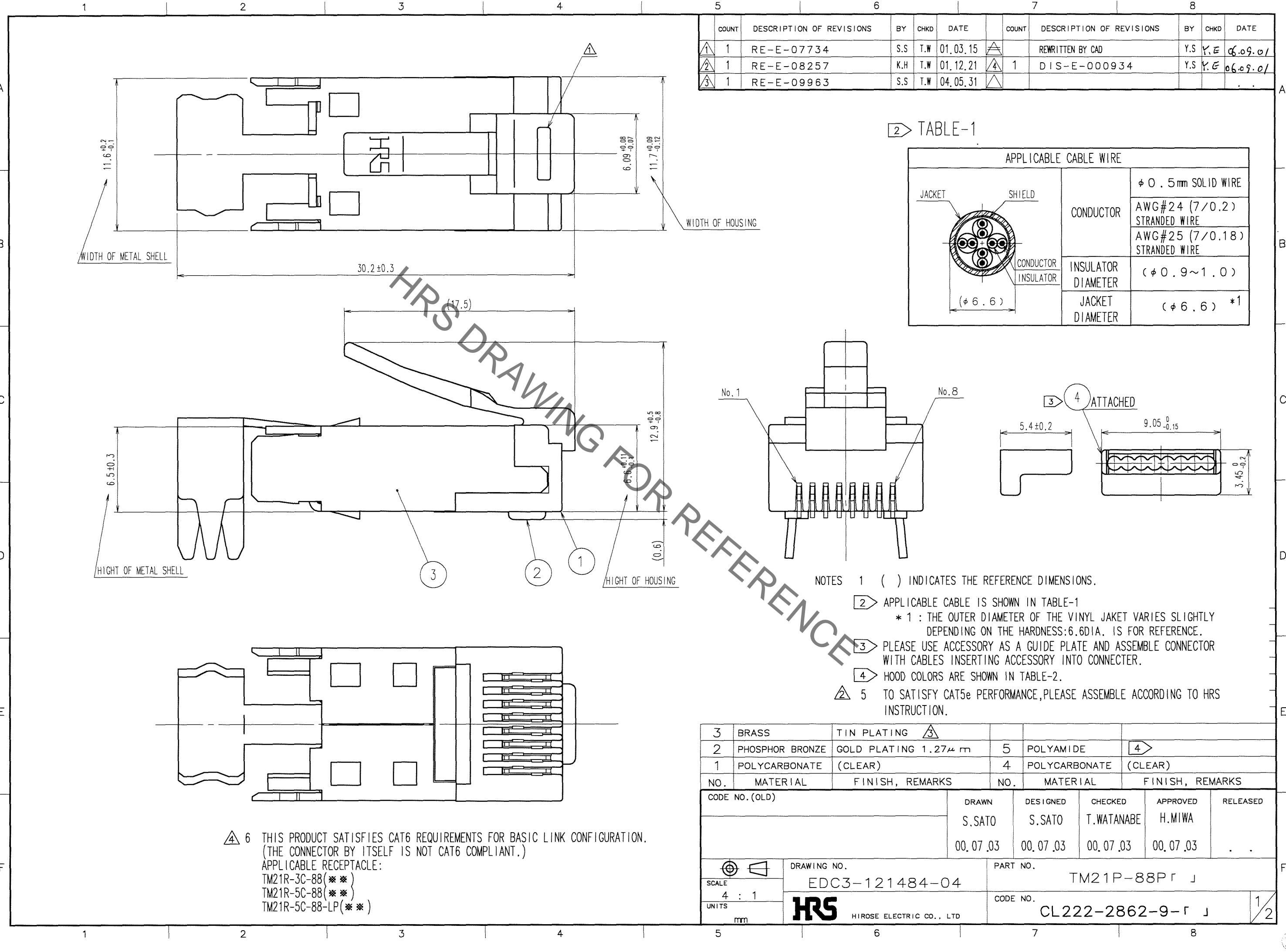

COUNT	DESCRIPTION OF REVISIONS	BY	CHKD	DATE	COUNT	DESCRIPTION OF REVISIONS	BY	CHKD	DATE
1	RE-E-07734	S.S	T.W	01.03.15	1	REWRITTEN BY CAD	Y.S	Y.E	06.09.01
1	RE-E-08257	K.H	T.W	01.12.21	1	DIS-E-000934	Y.S	Y.E	06.09.01
1	RE-E-09963	S.S	T.W	04.05.31					

TABLE-1

APPLICABLE CABLE WIRE	
CONDUCTOR	φ 0.5mm SOLID WIRE
	AWG#24 (7/0.2) STRANDED WIRE
INSULATOR DIAMETER	AWG#25 (7/0.18) STRANDED WIRE
	(φ 0.9~1.0)
JACKET DIAMETER	(φ 6.6) *1

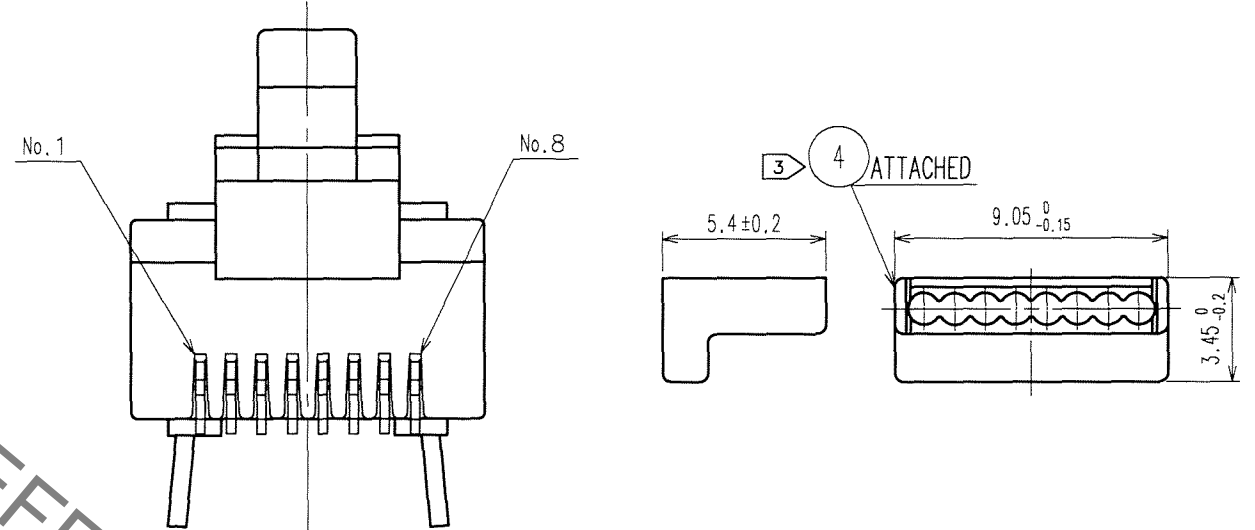
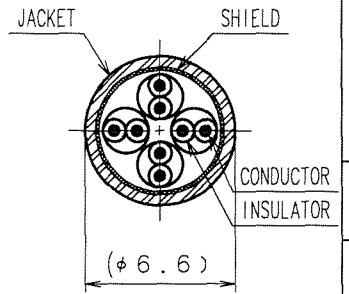

- NOTES
- 1 ( ) INDICATES THE REFERENCE DIMENSIONS.
  - 2 APPLICABLE CABLE IS SHOWN IN TABLE-1
  - \* 1 : THE OUTER DIAMETER OF THE VINYL JAKET VARIES SLIGHTLY DEPENDING ON THE HARDNESS:6.6DIA. IS FOR REFERENCE.
  - 3 PLEASE USE ACCESSORY AS A GUIDE PLATE AND ASSEMBLE CONNECTOR WITH CABLES INSERTING ACCESSORY INTO CONNECTOR.
  - 4 HOOD COLORS ARE SHOWN IN TABLE-2.
  - 5 TO SATISFY CAT5e PERFORMANCE, PLEASE ASSEMBLE ACCORDING TO HRS INSTRUCTION.

6 THIS PRODUCT SATISFIES CAT6 REQUIREMENTS FOR BASIC LINK CONFIGURATION. (THE CONNECTOR BY ITSELF IS NOT CAT6 COMPLIANT.)  
 APPLICABLE RECEPTACLE:  
 TM21R-3C-88(\*\*)  
 TM21R-5C-88(\*\*)  
 TM21R-5C-88-LP(\*\*)

NO.	MATERIAL	FINISH, REMARKS	NO.	MATERIAL	FINISH, REMARKS
3	BRASS	TIN PLATING	5	POLYAMIDE	
2	PHOSPHOR BRONZE	GOLD PLATING 1.27μm	4	POLYCARBONATE	(CLEAR)
1	POLYCARBONATE	(CLEAR)			

CODE NO. (OLD)	DRAWN	DESIGNED	CHECKED	APPROVED	RELEASED
	S.SATO	S.SATO	T.WATANABE	H.MIWA	
	00.07.03	00.07.03	00.07.03	00.07.03	

  

SCALE	DRAWING NO.	PART NO.
4 : 1	EDC3-121484-04	TM21P-88P「J」
UNITS	mm	CODE NO.
	HRS HIROSE ELECTRIC CO., LTD	CL222-2862-9-「J」

TO
Q

Jul.1.2020 Copyright 2020 HIROSE ELECTRIC CO., LTD. All Rights Reserved.  
 In case of consideration for using Automotive equipment / device which demand high reliability, kindly contact our sales window correspondents.

COUNT	DESCRIPTION OF REVISIONS	BY	CHKD	DATE	COUNT	DESCRIPTION OF REVISIONS	BY	CHKD	DATE
△					△				
△					△				
△					△				

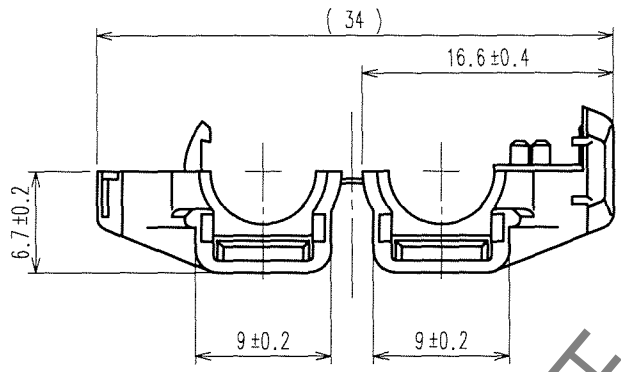

4 TABLE-2

PART NO.	HRS NO.	COLOR
TM21P-88P	CL222-2862-9	LIGHT BEIGE
TM21P-88P(02)	CL222-2862-9(02)	MEDIUM GRAY
TM21P-88P(03)	CL222-2862-9(03)	BLACK
TM21P-88P(04)	CL222-2862-9(04)	NATURAL LIGHT GRAY
TM21P-88P(05)	CL222-2862-9(05)	RED
TM21P-88P(06)	CL222-2862-9(06)	GREEN
TM21P-88P(07)	CL222-2862-9(07)	BLUE
TM21P-88P(08)	CL222-2862-9(08)	YELLOW
TM21P-88P(09)	CL222-2862-9(09)	ORANGE

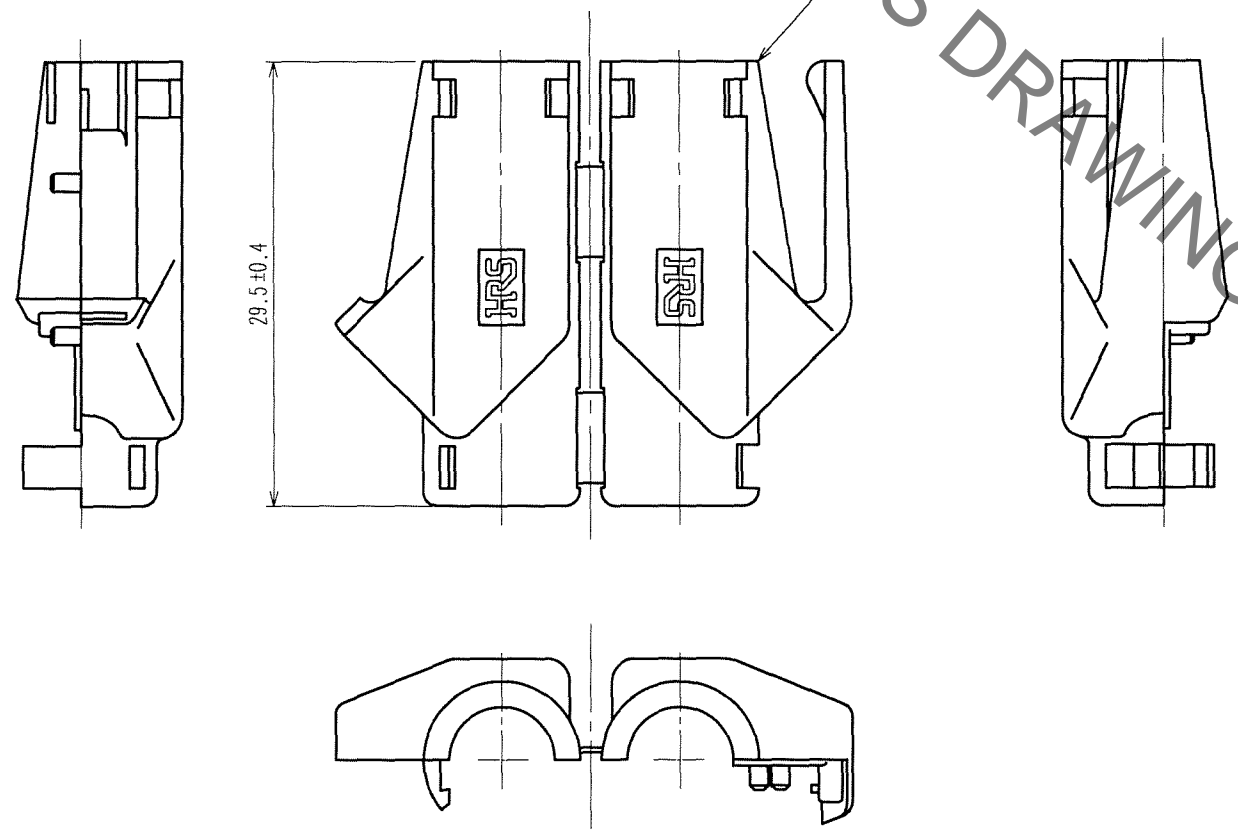

HOOD ATTACHMENT PROCEDURE (FREE)

1. FIT THE OPENED HOOD ON THE CABLE AND CLOSE. HOOD DIRECTION IS SHOWN AS AN EXAMPLE.

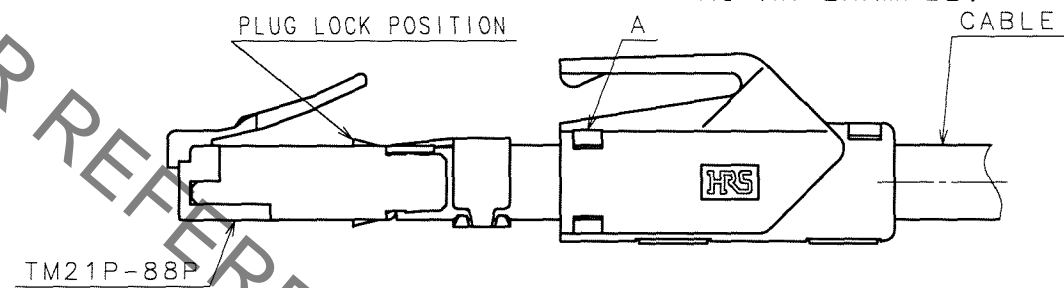

2. SLIDE THE CLOSED HOOD TO THE PLUG LOCK POSITION UNTIL BEING LOCKED AT A.

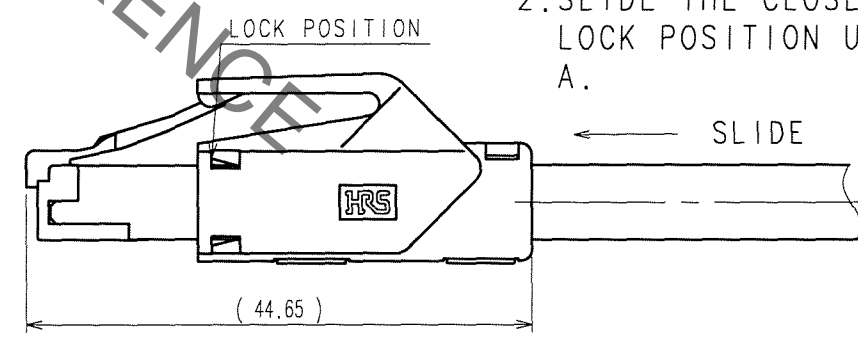

TO
Q2

NO.	MATERIAL	FINISH, REMARKS	NO.	MATERIAL	FINISH, REMARKS		
CODE NO. (OLD)			DRAWN	DESIGNED	CHECKED	APPROVED	RELEASED
			S.SATO	S.SATO	T.WATANABE	H.MIWA	
			00.07.03	00.07.03	00.07.03	00.07.03	
DRAWING NO. EDC3-121484-04			PART NO. TM21P-88P 「 J 」				
SCALE 2 : 1			CODE NO. CL222-2862-9- 「 J 」			2/2	
UNITS mm			HIROSE ELECTRIC CO., LTD				