

OSICONCEPT™ Limit Switches

XCKP, D, and T Compact Modular Description

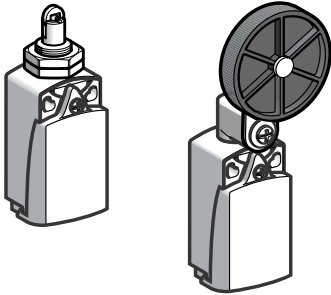

XCKP

The XCK compact limit switches are now available in both plastic and metal bodies. A plastic wide body, the XCKT, is also offered. These limit switches incorporate a modular design that allows all the metal heads to fit any of the compact switch bodies, as well as the XCMD miniature limit switch bodies.

XCKP and XCKT modular compact switches replace our previous plastic compact switches. They are a direct replacement for these non-modular switches.

XCKD is the new all metal compact switch. It is modular and can be used in outdoor applications requiring a more rugged switch. The XCKD is dimensionally similar to the previous plastic switches and can replace them without re-drilling in most cases.

The manual reset versions of the above are the metal XCDDR, and the plastic XCPR, and XCTR.

See features and benefits on page 417 for additional details.

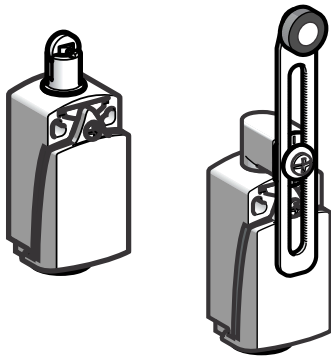

XCKD

General Specifications		
Conforming To Standards	Products	IEC 60 947-5-1, EN 60 947-5-1, UL 508, CSA C22-2 no. 14
	Machine assemblies	IEC 60 204-1, EN 60 204-1
Product Certifications		UL, CSA, CE
Protective Treatment	Standard version	"TC"
Ambient Air Temperature	Operation	-13 to + 158°F (- 25 to + 70°C)
	Storage	-40 to 158°F (-40 to + 70°C)
Vibration Resistance	Conforming to IEC 60 068-2-6	25 gn (10–500 Hz)
Shock Resistance	Conforming to IEC 60 068-2-27	50 gn (11 msec.), ZCE08: 15 gn (11 ms) and ZCE24: 30 gn (18 ms)
Electric Shock Protection		Class II conforming to IEC 61140 and NF C 20-030 for XCK P and XCK T Class I conforming to IEC 61140 and NF C 20-030 for XCK D
Degree of Protection		IP66 and IP67 conforming to IEC 60 529; IK.04 conforming to EN 50 102 for XCK P and XCK T, IK.0G conforming to EN 50 102 for XCK D
Repeat Accuracy		0.1 mm on tripping points
Cable Entry	Depending on model	Tapped entry for cable gland 11 or 13, or ISO M16x1.5 tapped, ISO M20x1.5 tapped or 1/2" NPT tapped or PF 1/2 tapped
Materials		XCK D: zinc alloy body and head; XCK P and XCK T: plastic body and zinc alloy head

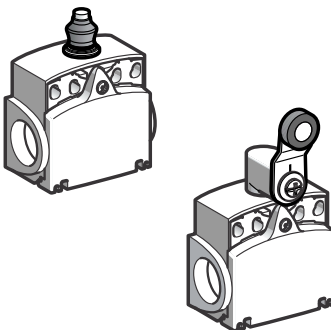

XCKT

OSICONCEPT™ Limit Switches XCKP and XCKD Compact Modular Features and Benefits Comparison

This table compares the new plastic compact body XCKP to the previous plastic design and introduces the XCKD. All heads on plastic or metal bodies are metal. The metal compact XCKD was designed for more rugged applications including outdoor use. The XCKD features are the same as the XCKP and the XCKD uses the same new metal heads as the new plastic XCKP.

New XCKP Plastic and XCKD Metal		Previous Plastic XCKP
Features	Benefits	Features
Modular	Easy to change components	Non-modular
Metal head	Rugged, robust	Plastic
No screw head attachment	Easy to change heads	4 screws required
Head release fork blocked by cover	Helps prevent tampering	N/A
Heads rotate and adjust in 15 degree increments (levers adjust in 15 degree increments)	Precise positioning of head	not recommended
Many heads available	More variety for difficult applications	Basic heads available
Lever travel increased to 90 degrees	Reduces chance of damage to switch mechanism	70 degree travel
Enclosure rating IP 66 and 67, Type 4X	Greater protection from leakage	IP 65
Metal plate over screw holes (not required on metal body)	No plastic deformation	Plastic only
Angular sloped cover	Better access to the contact block, better sealing pressure around the gasket	Flat cover
Contact block design	Improves ease of wiring	Flat design
Up to 3 contacts will be available	Allows easy circuit redundancy	2 contacts maximum
6 separate component thread adaptors	Versatility, late differentiation	Molded threads in body
Modular components	Reduce distributor inventory (the same metal heads are used on metal and plastic compact and miniature body style limit switches)	Non-modular
Same mounting as our existing and most competitive compact switches	No re-drilling required for most applications	
Assembly of components in the US	Late differentiation, quicker delivery on non stock and specials	Made in Spain

OSICONCEPT™ Limit Switches XCKP, D, and T Compact Modular Specifications



Contact Characteristics		
Rated Operational Characteristics	XE2• P	AC-1; A300 (Ue = 240 V, Ie = 3 A); Ithe = 10 A DC-13; Q300 (Ue = 250 V, Ie = 0.27 A), conforming to IEC 60-947-5-1 Appendix A, EN 60 947-5-1
	XE3• P	AC-15; B300 (Ue = 240 V, Ie = 1.5 A); Ithe = 6 A DC-13; R300 (Ue = 250 V, Ie = 0.1 A) conforming to IEC 60 947-5-1 Appendix A, EN 60 947-5-1
Rated Insulation Voltage	XE2• P	Ui = 500 V degree of pollution 3 conforming to IEC 60 947-1, Ui = 300 V conforming to UL 508, CSA C22-2 No. 14
	XE3• P	Ui = 400 V degree of pollution 3 conforming to IEC 60 947-1, Ui = 300 V conforming to UL 508, CSA C22-2 No. 14
Rated Impulse Withstand Voltage	XE2• P	U imp = 6 kV conforming to IEC 60 947-1, IEC 60 664
	XE3• P	U imp = 4 kV conforming to IEC 60 947-1, IEC 60 664
Positive Operation (depending on model)	Contact with positive opening operation conforming to IEC 60 947-5-1 Appendix K, EN 60 947-5-1	
Resistance Across Terminals	≤ 25 mΩ conforming to IEC 60 255-7 Category 3	
Short-circuit Protection	XE2• P	10 A cartridge fuse gG (gl)
	XE3• P	6 A cartridge fuse gG (gl)
Connection (on screw and cable clamp terminals)	XE2S P•151 and XE2S P2141	Clamping capacity: minimum 0.04 x 0.01 ² (1 x 0.34 mm ²), maximum 0.08 x 0.06 ² (2 x 1.5 mm ²)
	XE2N P21•1 and XE2N P31•1	Clamping capacity: minimum 0.04 x 0.02 ² (1 x 0.5 mm ²), maximum 0.08 x 0.01 ² (2 x 2.5 mm ²)
	XE3N P and XE3S P	Clamping capacity: minimum 0.04 x 0.01 ² (1 x 0.34 mm ²), maximum 0.04 x 0.04 ² (1 x 1 mm ²) or 0.08 x 0.03 ² (2 x 0.75 mm ²)
Minimum Actuation Speed	XE2S P•151, XE2S P2141 and XE3S P: 0.01 m/minute XE2N P21•1, XE2N P31•1 and XE3N P: 6 m/minute	
Electrical Durability	Conforming to IEC 60 947-5-1 Appendix C Use categories AC-15 and DC-13 Max. frequency: 3600 operating cycles/hour Load factor: 0.5	

Alternating Current 50/60 Hz
Inductive Circuit

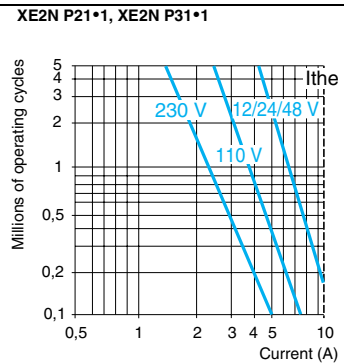
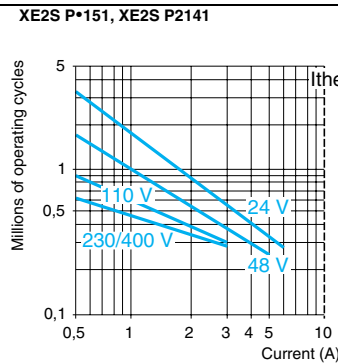

Direct Current

Power switching for 5 million operating cycles			
Voltage V	24	48	120
W	10	7	4

Power switching for 5 million operating cycles			
Voltage V	24	48	120
W	13	9	7

For XE2S P•151 in AC or DC, the N.C. and N.O. contacts are supplied with the indicated values to the same polarity simultaneously.

Alternating Current 50/60 Hz
Inductive Circuit

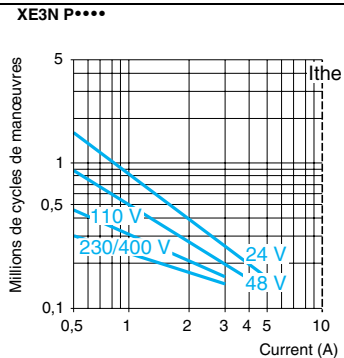
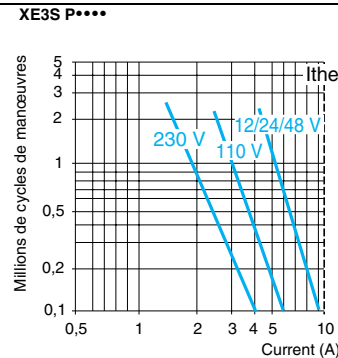

Direct Current

Power switching for 5 million operating cycles.			
Voltage V	24	48	120
W	4	3	2

Power switching for 5 million operating cycles			
Voltage V	24	48	120
W	3	2	1



For Interpretation of the Catalog Number Only

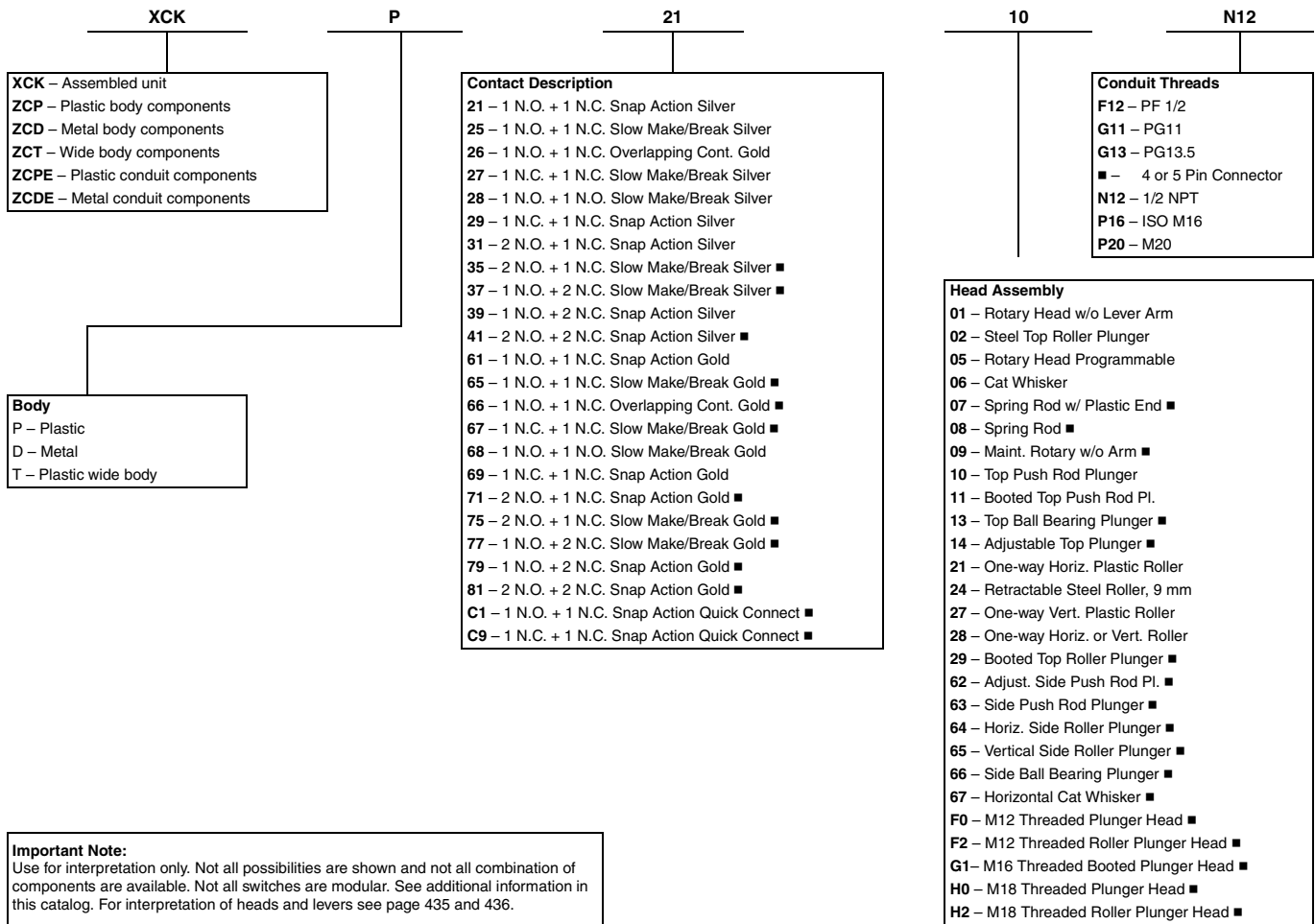

Important Note:
Use for interpretation only. Not all possibilities are shown and not all combination of components are available. Not all switches are modular. See additional information in this catalog. For interpretation of heads and levers see page 435 and 436.

■ Call your local field sales office for availability.

OSICONCEPT™ Limit Switches

XCKP Compact Modular Selection



Type of Operating Head Linear movement, body-mounted

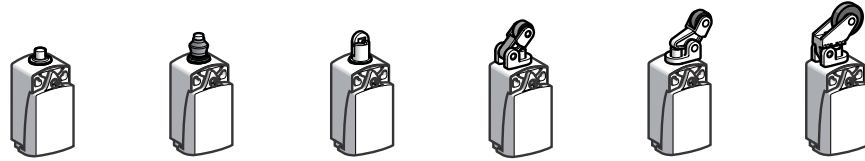

Type of Operator	Metal top plunger	Metal top plunger with elastomer boot	Steel roller plunger	Thermoplastic roller lever, one-way horizontal action	Thermoplastic roller lever, one-way vertical action	Thermoplastic roller lever, one-way vertical or horizontal action
------------------	-------------------	---------------------------------------	----------------------	---	---	---

Catalog Numbers (2)

<p>2-pole N.C. + N.O. snap action contact (XE2S P2151)</p>	XCKP 2110N12 	XCKP 2111N12 	XCKP 2102N12 	XCKP 2121N12 	XCKP 2127N12 	XCKP 2128N12
<p>2-pole N.C. + N.O. slow break-before-make contact (XE2N P2151)</p>	XCKP 2510N12 	XCKP 2511N12 	XCKP 2502N12 	XCKP 2521N12 	XCKP 2527P16 	XCKP 2528N12
<p>2-pole N.C. + N.C. snap action contact (XE2S P2141)</p>	ZCP 29 + ZCPE N12 + ZCE 10 	ZCP 29 + ZCPE N12 + ZCE 11 	ZCP 29 + ZCPE N12 + ZCE 02 	ZCP 29 + ZCPE N12 + ZCE 21 	ZCP 29 + ZCPE N12 + ZCE 27 	ZCP 29 + ZCPE N12 + ZCE 28
<p>2-pole N.C. + N.C. slow break-before-make contact (XE2N P2141)</p>	ZCP 27 + ZCPE N12 + ZCE 10 	ZCP 27 + ZCPE N12 + ZCE 11 	ZCP 27 + ZCPE N12 + ZCE 02 	ZCP 27 + ZCPE N12 + ZCE 21 	ZCP 27 + ZCPE N12 + ZCE 27 	ZCP 27 + ZCPE N12 + ZCE 28
<p>3-pole N.C. + N.C. + N.O. snap action contact (XE3S P2141)</p>	ZCP 39 + ZCPE N12 + ZCE 10 	ZCP 39 + ZCPE N12 + ZCE 11 	ZCP 39 + ZCPE N12 + ZCE 02 	ZCP 39 + ZCPE N12 + ZCE 21 	ZCP 39 + ZCPE N12 + ZCE 27 	ZCP 39 + ZCPE N12 + ZCE 28
<p>3-pole N.C. + N.C. + N.O. slow break-before-make contact (XE3N P2141)</p>	ZCP 37 + ZCPE N12 + ZCE 10 	ZCP 37 + ZCPE N12 + ZCE 11 	ZCP 37 + ZCPE N12 + ZCE 02 	ZCP 37 + ZCPE N12 + ZCE 21 	ZCP 37 + ZCPE N12 + ZCE 27 	ZCP 37 + ZCPE N12 + ZCE 28
Weight lb (kg)	0.19 (0.090)	0.19 (0.090)	0.2 (0.095)	0.23 (0.105)	0.22 (0.100)	0.23 (0.105)

Contact Operation contact closed contact open (A)/(B) = cam displacement (P) = direct opening point ⊕ N.C. contact with direct opening contact

Characteristics

Switch Actuation On end By 30° cam

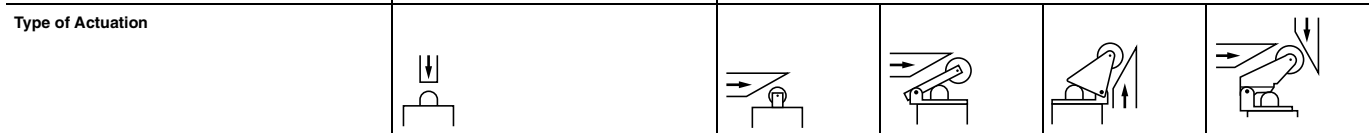

Maximum Actuation Speed 0.5 m/sec. 1 m/sec.

Minimum Force of Torque for tripping 133 lb-in (15 N•m) 106 lb-in (12 N•m) 53 lb-in (6 N•m)
for direct opening 398 lb-in (45 N•m) 318 lb-in (36 N•m) 159 lb-in (18 N•m)

Type of Output Connection (1) 1 tapped entry, 1/2" NPT

(1) For a cable entry PG11, replace N12 with G11. Example: XCKD 2110N12 becomes XCKD 2110G11 or ZCDE N12 becomes ZCDE G11.
 (2) For devices with gold or ring-tongue contacts, contact your regional office.

Limit Switches

Type of Operating Head	Linear movement, head-mounted		Rotary movement, body-mounted				Multi-directional

Type of Operator	M18 with metal top plunger	M18 with steel roller plunger	Thermoplastic roller lever	Adjustable length lever arm with thermoplastic roller	Thermoplastic roller lever, Ø 50 mm	Adjustable length lever arm with thermoplastic roller, Ø 50 mm	Cat whisker (3)
------------------	----------------------------	-------------------------------	----------------------------	---	-------------------------------------	--	-----------------

Catalog Numbers (2)	XCKP 21H0N12	XCKP 21H2N12	XCKP 2118N12	XCKP 2145N12	XCKP 2139N12	XCKP 2149N12	XCKP 2106N12
 2-pole N.C. + N.O. snap action contact (XE2S P2151)	 1.8 4.5(P) 0.9 5mm	 3.1(A) 7.8(P) 1.5 mm	 25° 70°(P) 12° 90°	 25° 70°(P) 12° 90°	 25° 70°(P) 12° 90°	 25° 70°(P) 12° 90°	 20° 15°
 2-pole N.C. + N.O. slow break-before-make contact (XE2N P2151)	 1.8 3.2(P) 0 3 5mm	 3.1(A) 5.6(P) 0 5.2 mm	 25° 70°(P) 13-14 0 42° 90°	 25° 70°(P) 13-14 0 42° 90°	 25° 70°(P) 13-14 0 42° 90°	 25° 70°(P) 13-14 0 42° 90°	 20° 0 45°
 2-pole N.C. + N.C. snap action contact (XE2S P2141)	 1.8 4.5(P) 0.9 5mm	 3.1(A) 7.8(P) 1.5 mm	 25° 70°(P) 12° 90°	 25° 70°(P) 12° 90°	 25° 70°(P) 12° 90°	 25° 70°(P) 12° 90°	 20° 15°
 2-pole N.C. + N.C. slow break-before-make contact (XE2N P2141)	 1.8 3.2(P) 0 3 5mm	 3.1 5.6(P) 0 5.2 mm	 25° 70°(P) 11-12 0 42° 90°	 25° 70°(P) 11-12 0 42° 90°	 25° 70°(P) 11-12 0 42° 90°	 25° 70°(P) 11-12 0 42° 90°	 20° 0
 3-pole N.C. + N.C. + N.O. snap action contact (XE3S P2141)	 1.8 4.5(P) 0.9 5mm	 3.1(A) 7.8(P) 1.5 mm	 25° 70°(P) 12° 90°	 25° 70°(P) 12° 90°	 25° 70°(P) 12° 90°	 25° 70°(P) 12° 90°	 20° 15°
 3-pole N.C. + N.C. + N.O. slow break-before-make contact (XE3N P2141)	 1.8 3.2(P) 0 3 5mm	 3.1(A) 5.6(P) 0 5.2 mm	 25° 70°(P) 21-22 0 42° 90°	 25° 70°(P) 21-22 0 42° 90°	 25° 70°(P) 21-22 0 42° 90°	 25° 70°(P) 21-22 0 42° 90°	 20° 0 45°
Weight lb (kg)	0.28 (0.130)	0.28 (0.130)	0.29 (0.135)	0.32 (0.145)	0.32 (0.145)	0.34 (0.155)	0.18 (0.085)
Contact Operation			(A) = cam displacement (P) = direct opening point	⊖ N.C. contact with direct opening operation			

Characteristics	On end		By 30° cam		By any type
Switch Actuation					
Type of Actuation					
Maximum Actuation Speed	0.5 m/sec.		1.5 m/sec.		1 m/sec., all directions
Minimum Force of Torque	for tripping	133 lb-in (15 N•m)	88.5 lb-in (10 N•m)	14.16 oz-in (0.1 N•m)	18.40 oz-in (0.13 N•m)
	for direct opening	398 lb-in (45 N•m)	318 lb-in (36 N•m)	35.40 oz-in (0.25 N•m)	-
Type of Output Connection (1)	One tapped entry, 1/2" NPT				

(1) For a cable entry PG11, replace N12 with G11. Example: XCKD 2110N12 becomes XCKD 2110G11 or ZCDE N12 becomes ZCDE G11.
 (2) For devices with gold or ring-tongue contacts, contact your regional office.
 (3) Value taken with mobile actuation at 3.9" (100 mm) from mounting attachment.

Limit Switches

OSICONCEPT™ Limit Switches

XCKP Compact Modular

Dimensions



ZCP 2* + ZCPE N12

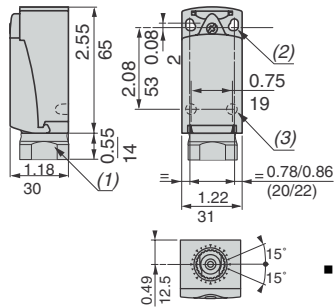

- (1) Threaded hole for M0.78 x 0.06" (20 x 1.5) for ISO cable gland or tapped PG13 or tapped 1/2 NPT
- (2) 2 oblong holes, $\varnothing 0.17 \times 0.25"$ (4.3 x 6.3 mm), 0.86 (22 mm) center-to-center or 2 holes, $\varnothing 0.17, 0.79"$ (4.3, 20 mm) center-to-center.
- (3) 2 locating holes for frame, $\varnothing 0.118"$ (3), depth: 0.16" (4 mm)

ZCE 10

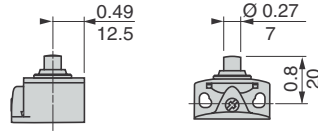

ZCE 11

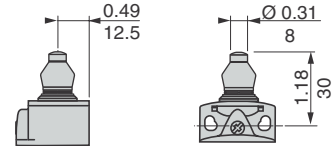

ZCE 02

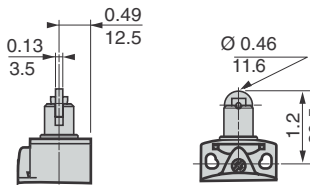

ZCE 21

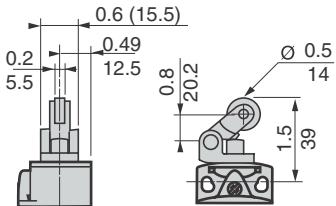

ZCE 27

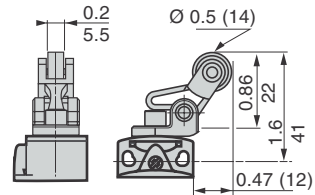

ZCE 28

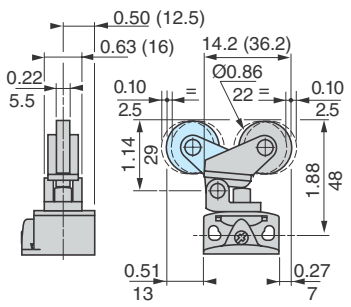

ZCE H0

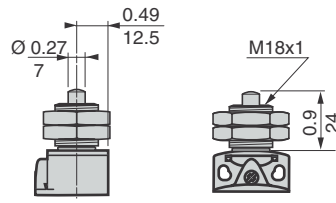

ZCE H2

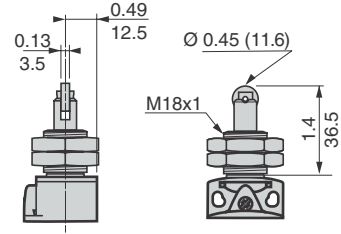

Dual Dimensions $\frac{\text{inches}}{\text{mm}}$

- (1) Hole tapped for ISO M0.63 x 0.06" (16 x 1.5) or PG11 cable gland or 1/2" NPT
- (2) 2 oblong holes, $\varnothing 0.17 \times 0.25"$ (4.3 x 6.3 mm), 0.86" (22 mm) center to center, or 2 holes, $\varnothing 0.17, 0.79"$ (4.3, 20 mm) center to center

■ Heads can be rotated in 15° increments thru 360°

Limit Switches

ZCE 01 + ZCY 18

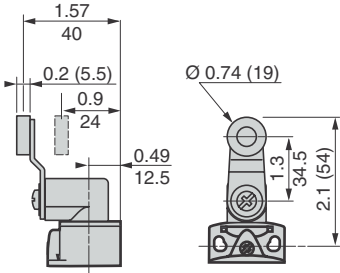

ZCE 01 + ZCY 45

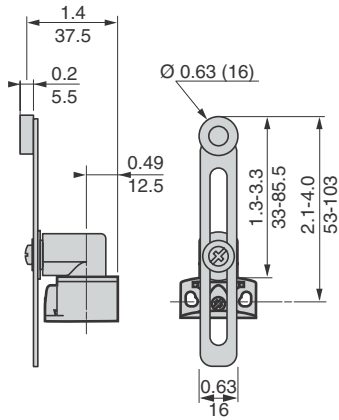

ZCE 01 + ZCY 39

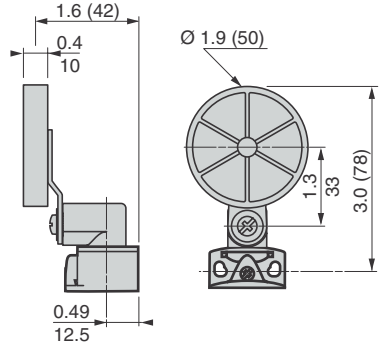

ZCE 01 + ZCY 49

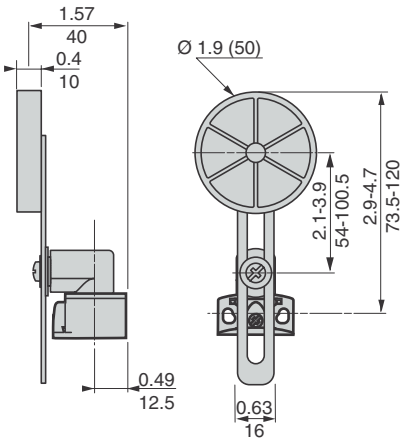

ZCE 06

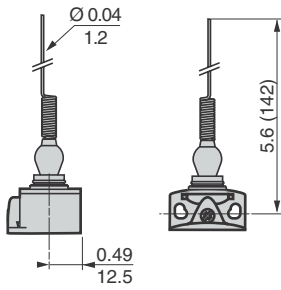

Dual Dimensions $\frac{\text{inches}}{\text{mm}}$

OSICONCEPT™ Limit Switches

XCKP Compact Modular with Connector Selection



Type of Operating Head	Linear movement, body-mounted
------------------------	-------------------------------

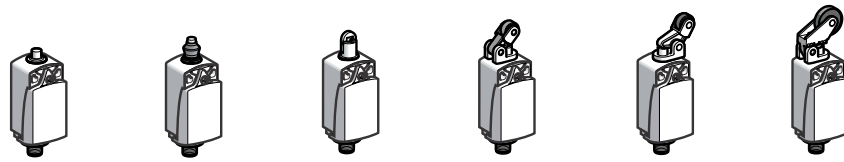

Type of Operator	Metal top plunger	Metal top plunger with elastomer boot	Steel roller plunger	Thermoplastic roller plunger, one-way horizontal action	Thermoplastic roller plunger, one-way vertical action	Thermoplastic roller plunger, one-way vertical or horizontal action
------------------	-------------------	---------------------------------------	----------------------	---	---	---

Catalog Numbers	XCK P2110M12	XCK P2111M12	XCK P2102M12	XCK P2121M12	XCK P2127M12	XCK P2128M12
2-pole N.C. + N.O. snap action contact (XE2S P2151)	1.8 4.5(P) 0.9 5mm	1.8 4.5(P) 0.9 5mm	3.1(A) 7.8(P) 1.5 mm	6.5(A) 15.7(P) 3 mm	6.5(B) 15.7(P) 3 mm	9.8(A) 22.5(P) 4.9 mm
2-pole N.C. + N.C. snap action contact (XE2S P2141)	1.8 4.5(P) 0.9 5mm	1.8 4.5(P) 0.9 5mm	3.1(A) 7.8(P) 1.5 mm	6.5(A) 15.7(P) 3 mm	6.5(B) 15.7(P) 3 mm	9.8(A) 22.5(P) 4.9 mm
Weight lb (kg)	0.22 (0.100)	0.22 (0.100)	0.22 (0.100)	0.24 (0.110)	0.24 (0.110)	0.24 (0.110)
Contact Operation			(A)(B) = cam displacement (P) = direct opening point			

Characteristics	On end	By 30° cam
Switch Actuation		
Type of Actuation		
Maximum Actuation Speed	0.5 m/sec.	1 m/sec.
Minimum Force of Torque	for tripping: 15 oz-in (0.10 N•m) for direct opening: 45 oz-in (0.31 N•m)	12 oz-in (0.08 N•m) 6 oz-in (0.04 N•m)
Type of Output Connection	By M12 connector, Ui = 250 V, Ie = 3 A max. Ith = 3 A (see page 403 for female connection adapters)	

Connections
By M12 connector
4: XE2SP 2151 1-2: N.C. 3-4: N.O.
XE2SP 2141 1-2: N.C. 3-4: N.C.

Dimensions	ZCE 10	ZCE 11	ZCE 02	ZCE 21	ZCE 27	ZCE 28	ZCE H0
ZCP 2•M12							
(1) 2 oblong holes, Ø 0.17 x 0.25" (4.3 x 6.3 mm), 0.86" (22 mm) center to center, or 2 holes, Ø 0.17", 0.79" (4.3, 20 mm) center to center							
Heads can be rotated in 15° increments thru 360°							
Dual Dimensions	inches / mm						

Limit Switches

Type of Operating Head	Linear movement, head-mounted		Rotary movement, body-mounted			Multi-directional	
Type of Operator	M18 with metal top plunger	M18 with steel roller plunger	Thermoplastic roller lever	Adjustable length lever arm with thermoplastic roller	Thermoplastic roller lever, Ø 50 mm	Adjustable length lever arm with thermoplastic roller, Ø 50 mm	Cat whisker (1)

Catalog Numbers							
2-pole N.C. + N.O. snap action contact (XE2S P2151) 	XCK P21H0M12 ⊖	XCK P21H2M12 ⊖	XCK P2118M126 ⊖	XCK P2145M12 ⊖	XCK P2139M12 ⊖	XCK P2149M12 ⊖	XCK P2106M126
2-pole N.C. + N.C. snap action contact (XE2S P2141) 	ZCP 29M12 + ZCE H0 ⊕	ZCP 29M12 + ZCE H2 ⊖	ZCP 29M12 + ZCE 01 + ZCY 18 ⊕	ZCP 29M12 + ZCE 01 + ZCY 45 ⊖	ZCP 29M12 + ZCE 01 + ZCY 39 ⊕	ZCP 29M12 + ZCE 01 + ZCY 49 ⊕	ZCP 29M12 + ZCE 06
Weight lb (kg)	0.31 (0.140)	0.31 (0.140)	0.31 (0.140)	0.33 (0.150)	0.34 (0.155)	0.35 (0.160)	0.19 (0.090)
Contact Operation			(A) = cam displacement (P) = direct opening point	⊖ N.C. contact with direct opening operation			
(1) Value taken with mobile actuation at 100 mm from mounting attachment.							

Characteristics					
Switch Actuation	On end		By 30° end		By any type
Type of Actuation					
Maximum Actuation Speed	0.5 m/sec.		1.5 m/sec.		1 m/sec., all directions
Minimum Force of Torque	for tripping 133 lb-in (15 N•m)	88.5 lb-in (10 N•m)	14.16" oz-in (0.1 N•m)		18.40" oz-in (0.13 N•m)
	for direct opening 398 lb-in (45 N•m)	318 lb-in (36 N•m)	35.40" ox-in (0.25 N•m)		-
Type of Output Connection	M12 connector, maximum 4 A / 24 V (see page 403 for female connection adapters)				

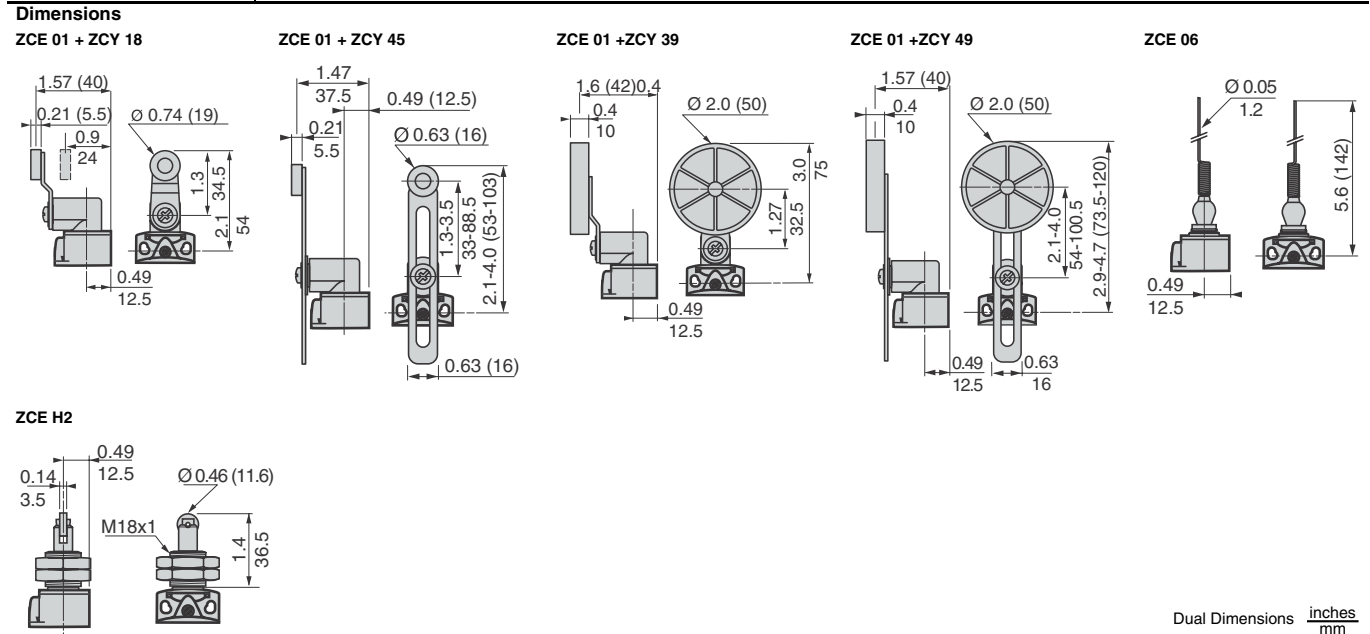

Limit Switches