



MULTI MICRO HORNET

ORG1518-MK06

GPS / GNSS MODULE WITH INTEGRATED / EXTERNAL
ANTENNA SUPPORT.

Datasheet

OriginGPS.com



INDEX

1.	SCOPE	5
2.	DISCLAIMER	5
3.	SAFETY INFORMATION	5
4.	ESD SENSITIVITY	5
5.	CONTACT INFORMATION.....	5
6.	RELATED DOCUMENTATION	5
7.	REVISION HISTORY	6
8.	GLOSSARY	7
9.	ABOUT HORNET FAMILY	9
10.	ABOUT MULTI HORNET MODULE	9
11.	ABOUT ORIGINGPS	9
12.	DESCRIPTION	10
12.1.	FEATURES.....	10
12.2	Architecture.....	10
12.3	ORG1518-MK06 FEATURES DESCRIPTION.....	12
12.3.1	CONSTELLATION CONFIGURATION	12
12.3.2	1 PPS.....	12
12.3.3	Static Navigation	12
12.3.4	Assisted GPS (AGPS).....	12
12.3.4.1	Locally-generated AGPS (Embedded Assisted system - EASY)	13
12.3.4.2	Server-Generated AGPS (Extended Prediction Orbit- EPO)	13
12.3.4.3	HotStill - EASY (Extended Prediction Orbit-).....	13
12.3.5	Quasi-Zenith Satellite System (QZSS)	14
12.3.6	Satellite-Based Augmentation System (SBAS).....	14
12.3.7	Diferential GPS (DGPS)	14
12.3.8	Jamming Rejection – Active InterferenceCancellation(AIC).....	14
12.3.9	Power Management Modes.....	14
12.3.9.1	Full Power Continuous Modes.....	15
12.3.9.2	Standby Mode.....	15
12.3.9.3	Periodic Mode.....	15
12.3.9.4	AlwaysLocate Mode.....	16
12.3.9.5	Backup Mode.....	16
12.3.9.6	Configuration Settings.....	17
12.4	PADS ASSIGNMENT – ORG1518-MK06	20
13.	MECHANICAL SPECIFICATIONS	21
14.	ELECTRICAL SPECIFICATIONS	19
14.1.	ABSOLUTE MAXIMUM RATINGS	19
14.2.	RECOMMENDED OPERATING CONDITIONS.....	23
15.	PERFORMANCE	24
15.1.	ACQUISITION TIME	24
15.1.1.	HOT START	24
15.1.2.	SIGNAL REACQUISITION.....	24
15.1.3.	AIDED START	24
15.1.4.	WARM START.....	24
15.1.5.	COLD START	24
15.2.	SENSITIVITY	25
15.2.1.	TRACKING	25
15.2.2.	REACQUISITION	25
15.2.3.	NAVIGATION	25
15.2.4.	HOT START	25
15.2.5.	AIDED START.....	25
15.2.6.	COLD START	25
15.3.	RECEIVED SIGNAL STRENGTH	26
15.4.	POWER CONSUMPTION.....	26
15.5.	POSITION ACCURACY	26



15.6.	DYNAMIC CONSTRAINS.....	27
16.	INTERFACE	27
16.1.	POWER SUPPLY.....	27
16.1.1.	Nominal VCC = 3.3V	27
16.1.2.	GROUND	27
16.2.	CONTROL INTERFACE.....	27
16.2.1	UART- HOST INTERFACE	27
16.2.1.1	TX	27
16.2.1.2	RX.....	27
16.2.2	I2C- HOST INTERFACE	28
16.3.	HARDWARE INTERFACE	28
16.3.1	FORCE-ON	28
16.3.2	RESET	28
16.3.3	1 PPS	28
16.3.4	WAKEUP.....	28
17.	TYPICAL APPLICATION CIRCUIT.....	29
18.	RECOMMENDED PCB LAYOUT	29
19.	DESIGN CONSIDERATIONS	26
20.	COMMANDS DESCRIPTION	27
21.	FIRMWARE UPDATES.....	27
22.	HANDLING INFORMATION.....	28
22.1.	MOISTURE SENSITIVITY.....	28
22.2.	ASSEMBLY	28
22.3.	SOLDERING	28
22.4.	CLEANING	29
22.5.	REWORK.....	29
22.6.	ESD SENSITIVITY.....	29
22.7.	SAFETY INFORMATION	29
22.8.	DISPOSAL INFORMATION	29
23.	COMPLIANCE	33
24.	PACKAGING AND DELIVERY	30
24.1.	APPEARANCE	34
24.2.	CARRIER TAPE	35
24.3.	REEL	36
25.	ORDERING INFORMATION.....	37
APPENDIX 1 – MULTI MICRO HORNET ORG1518-MK06.....		38

TABLE INDEX

TABLE 1 – RELATED DOCUMENTATION	5
TABLE 2 – REVISION HISTORY	6
TABLE 3 – PIN-OUT ORG1518-MK06.....	20
TABLE 4 – MECHANICAL SUMMARY	19
TABLE 5 – ABSOLUTE MAXIMUM RATINGS	19
TABLE 6 – RECOMMENDED OPERATING CONDITIONS	23
TABLE 7 – ACQUISITION TIME.....	24
TABLE 8 – SENSITIVITY	25
TABLE 9 – RECEIVED SIGNAL STRENGTH.....	26
TABLE 10 – POWER CONSUMPTION	26
TABLE 11 – POSITION ACCURACY	26
TABLE 12 – DYNAMIC CONSTRAINS.....	27
TABLE 13 – NMEA INPUT COMMANDS.....	27
TABLE 14 – SOLDERING PROFILE PARAMETERS.....	29
TABLE 15 – REEL QUANTITY	34
TABLE 16 – CARRIER TAPE DIMENSIONS	35
TABLE 17 – REEL DIMENSIONS.....	36
TABLE 18 – ORDERABLE DEVICES.....	37



FIGURE INDEX

FIGURE 1 – ORG1518-MK06 ARCHITECTURE	11
FIGURE 2 – MT3333 SYSTEM BLOCK DIAGRAM.....	11
FIGURE 3 – EASY TIMING	13
FIGURE 4 – PERIODIC POWER SAVING MODE	15
FIGURE 5 – ALWAYSLOCATE MODE	16
FIGURE 7 – MECHANICAL DRAWING	19
FIGURE 8 – 1PPS AND UTC TIMING.....	25
FIGURE 9 – REFERENCE SCHEMATIC DIAGRAM	26
FIGURE 10 – RECOMMENDED SOLDERING PROFILE.....	28
FIGURE 11 – MODULE POSITION	34
FIGURE 12 – CARRIER TAPE.....	35
FIGURE 13 – REEL.....	36
FIGURE 14 - ORDERING OPTIONS.....	32
FIGURE 15 – BATTERY BACKUP IMPLEMENTATION.....	33



1. SCOPE

This document describes the features and specifications of Multi Micro Hornet ORG1518-MK06 GNSS receiver module with integrated and external antenna.

2. DISCLAIMER

All trademarks are properties of their respective owners.

Performance characteristics listed in this document do not constitute a warranty or guarantee of product performance. OriginGPS assumes no liability or responsibility for any claims or damages arising out of the use of this document, or from the use of integrated circuits based on this document.

OriginGPS assumes no liability or responsibility for unintentional inaccuracies or omissions in this document.

OriginGPS reserves the right to make changes in its products, specifications and other information at any time without notice.

OriginGPS reserves the right to conduct, from time to time, and at its sole discretion, firmware upgrades.

As long as those FW improvements have no material change on end customers, PCN may not be issued.

OriginGPS navigation products are not recommended to use in life saving or life sustaining applications.

3. SAFETY INFORMATION

Improper handling and use can cause permanent damage to the product.

4. ESD SENSITIVITY

This product is ESD sensitive device and must be handled with care.



5. CONTACT INFORMATION

Support - support@origingps.com or [Online Form](#)

Marketing and sales - marketing@origingps.com , sales@origingps.com

Web – www.origingps.com

6. RELATED DOCUMENTATION

No	DOCUMENT NAME
1	Multi Micro Hornet – ORG1518-MK06 Evaluation Kit Datasheet
2	MTK NMEA Packet 3.5
3	MTK FAQ
4	Feature List and Command Usage- ORG4033, ORG1510MK-05 and ORG1518-MK06

TABLE 1 – RELATED DOCUMENTATION



7. REVISION HISTORY

REVISION	DATE	CHANGE DESCRIPTION	Author
1.0	3/ February	First version	Gil M.
1.1	6-Feb-19	Update block diagram +minor changes	Gil M.
1.2	May 30, 2019	Update Hotstill	Gil M.
1.3	17 June 2019	Update Standby	Gil M.
1.4	30 July, 2019	Updated TR2	Igor M.
1.5	September 5, 2019	Update PCB Layout link	Ron T.
1.6	September 19, 2020	Updated Static Navigation Updated I2C Pads	Ron T.

TABLE 2 – REVISION HISTORY

8. GLOSSARY

A-GPS Assisted **GPS**
AC Alternating **C**urrent
ADC Analog to **D**igital **C**onverter
AGC Automatic **G**ain **C**ontrol
BPF Band **P**ass **F**ilter
C/N₀ Carrier to **N**oise density ratio [dB-Hz]
CDM Charged **D**evice **M**odel
CE European Community conformity mark
CEP Circular **E**rror **P**robability
CMOS Complementary **M**etal-**O**xide **S**emiconductor
CPU Central **P**rocessing **U**nit
CTS Clear-**T**o-**S**end
CW Continuous **W**ave
DC Direct **C**urrent
DOP Dilution **O**f **P**recision
DR Dead **R**eckoning
DSP Digital **S**ignal **P**rocessor
ECEF Earth Centred Earth Fixed
ECHA European **C**hemical **A**gency
EGNOS European **G**eostationary **N**avigation **O**verlay **S**ervice
EIA Electronic Industries **A**lliance
EMC Electro-**M**agnetic **C**ompatibility
EMI Electro-**M**agnetic **I**nterference
ENIG Electroless **N**ickel **I**mmersion **G**old
ESD Electro-**S**tatic **D**ischarge
ESR Equivalent **S**eries **R**esistance
EU European **U**ion
EVB Evaluation **B**oard
EVK Evaluation **K**it
FCC Federal **C**ommunications **C**ommission
FSM Finite **S**tate **M**achine
GAGAN **G**PS **A**ided **G**eo-**A**ugmented **N**avigation
GNSS Global **N**avigation **S**atellite **S**ystem
GPIO General **P**urpose **I**nterface or **O**utput
GPS Global **P**ositioning **S**ystem
HBM Human **B**ody **M**odel
HDOP Horizontal **D**ilution **O**f **P**recision
I²C Inter-**I**ntegrated **C**ircuit
I/O **I**nterface or **O**utput
IC **I**ntegrated **C**ircuit
ICD **I**nterface **C**ontrol **D**ocument
IF **I**ntermediate **F**requency
ISO **I**nternational **O**rganization for **S**tandardization
JEDEC **J**oint **E**lectron **D**evice **E**ngineering **C**ouncil
KA **K**eep **A**live
KF **K**alman **F**ilter
LDO **L**ow **D**ropout regulator
LGA **L**and **G**rid **A**rray
LNA **L**ow **N**oise **A**mplifier
LP **L**ow **P**ower



LS Least Squares
LSB Least Significant Bit
MID Message Identifier
MM Machine Model
MSAS Multi-functional Satellite Augmentation System
MSB Most Significant Bit
MSL Moisture Sensitivity Level
NFZ™ Noise-Free Zones System
NMEA National Marine Electronics Association
NVM Non-Volatile Memory
PCB Printed Circuit Board
PLL Phase Lock Loop
PMU Power Management Unit
POR Power-On Reset
PPS Pulse Per Second
PRN Pseudo-Random Noise
PSRR Power Supply Rejection Ratio
PTF™ Push-To-Fix
QZSS Quasi-Zenith Satellite System
RAM Random Access Memory
REACH Registration, Evaluation, Authorisation and Restriction of Chemical substances
RF Radio Frequency
RHCP Right-Hand Circular Polarized
RMS Root Mean Square
RoHS Restriction of Hazardous Substances directive
ROM Read-Only Memory
RTC Real-Time Clock
RTS Ready-To-Send
SAW Surface Acoustic Wave
SBAS Satellite-Based Augmentation Systems
SID Sub-Identifier
SIP System In Package
SMD Surface Mounted Device
SMPS Switched Mode Power Supply
SMT Surface-Mount Technology
SOC System On Chip
SPI Serial Peripheral Interface
SV Satellite Vehicle
TCXO Temperature-Compensated Crystal Oscillator
TTF Time To First Fix
TTL Transistor-Transistor Logic
UART Universal Asynchronous Receiver/Transmitter
VCCI Voluntary Control Council for Interference by information technology equipment
VEP Vertical Error Probability
VGA Variable-Gain Amplifier
WAAS Wide Area Augmentation System

9. ABOUT HORNET FAMILY

OriginGPS GNSS receiver modules have been designed to address markets where size, weight, stand-alone operation, highest level of integration, power consumption and design flexibility - all are very important.

OriginGPS' Hornet family breaks size barrier, offering the industry's smallest fully-integrated, highly-sensitive GPS and GNSS modules with integrated antennas or on-board RF connectors.

Hornet family features OriginGPS' proprietary NFZ™ technology for high sensitivity and noise immunity even under marginal signal condition, commonly found in urban canyons, under dense foliage or when the receiver's position in space rapidly changes.

Hornet family enables the shortest TTM (Time-To-Market) with minimal design risks.

Just connect power supply on a single layer PCB.

10. ABOUT MULTI HORNET MODULE

Multi Hornet is a complete SiP featuring miniature LGA SMT footprint designed to commit unique integration features for high volume cost sensitive applications and dual antenna: integrated and external.

Designed to support compact and traditional applications such as smart watches, wearable devices, asset trackers, Multi Micro Hornet ORG1518-MK06 module is a miniature multi-channel GPS and GLONASS/BEIDOU, Galileo, SBAS, QZSS overlay systems receiver that continuously tracks all satellites in view, providing real-time positioning data in industry's standard NMEA format.

Multi Hornet ORG1518-MK06 module offers superior sensitivity and outstanding performance, achieving rapid TTFF in less than one second, accuracy of approximately two meters, and tracking sensitivity of -165dBm.

Sized only 18mm x 18mm Multi Hornet ORG1518-MK06 module is industry's small sized, record breaking solution.

Micro Hornet ORG1518-MK06 module is introducing industry's lowest energy per fix ratio, unparalleled accuracy and extremely fast fixes even under challenging signal conditions, such as in built-up urban areas, dense foliage or even indoor.

Integrated GPS SoC incorporating high-performance microprocessor and sophisticated firmware keeps positioning payload off the host, allowing integration in embedded solutions with low computing resources.

Innovative architecture can detect changes in context, temperature, and satellite signals to achieve a state of near continuous availability by maintaining and opportunistically updating its internal fine time, frequency, and satellite ephemeris data while consuming mere microwatts of battery power.

11. ABOUT ORIGINGPS

OriginGPS is a world leading designer, manufacturer and supplier of miniature positioning modules, antenna modules and antenna solutions.

System (NFZ™) proprietary technology for faster position fix and navigation stability even under challenging satellite signal conditions.

Founded in 2006, OriginGPS is specializing in development of unique technologies that miniaturize RF modules, thereby addressing the market need for smaller wireless solutions.

12. DESCRIPTION

12.1. FEATURES

- + Autonomous operation
- + RF switch controlled by logic level provides choice of integrated antenna or external passive antenna.
- + OriginGPS Noise Free Zone System (NFZ™) technology
- + Fully integrating: Antenna element, Dual-stage LNA, SAW filter, TCXO, RTC crystal, GNSS SoC, LDO regulator, RF shield, RF switch.
- + Concurrent tracking of multiple constellations
- + Control signal switches between integrated and external antenna.
- + Uses GPS, GLONASS GALILEO and BEIDOU, QZSS constellations.
- + GPS L1 1575.42 frequency, C/A code
- + GLONASS L1 FDMA 1598-1606MHz frequency band, SP signal.
- + GALILEO E1 1575.42MHz frequency
- + BEIDOU B1 1561.098MHz frequency band.
- + SBAS (WAAS, EGNOS, MSAS and GAGAN)
- + DGPS capability
- + 99 search channels and 33 simultaneous tracking channels
- + Ultra-high Sensitivity down to -165dBm enabling Indoor Tracking
- + TTFF of < 1s in 50% of trials under Hot Start conditions
- + Low Power Consumption of ≤ 15mW
- + High Accuracy of < 2.5m in 50% of trials
- + AGPS support: Embedded Assist System (EASY) and Extended Prediction Orbit (EPO)
- + Indoor and outdoor Multipath and cross-correlation mitigation
- + Jamming Rejection – 12 multi-tone Active Interference Cancellation (AIC)
- + 8 Megabit built in flash
- + Power management modes: Full Power Continuous, Standby, Periodic and AlwaysLocate™
- + NMEA commands and data output over UART / I2C or UART /SPI interface
- + High update messages rate of 1,2,5,10Hz
- + 1PPS Output
- + Static Navigation
- + Single voltage supply 3.3V with battery input
- + Ultra-small LGA footprint of 17mm x 17mm
- + Ultra-low weight of 8g
- + Surface Mount Device (SMD)
- + Optimized for automatic assembly and reflow equipment
- + Operating from -40°C to +85°C
- + FCC, CE, VCCI compliant
- + RoHS II/REACH compliant

12.2. ARCHITECTURE

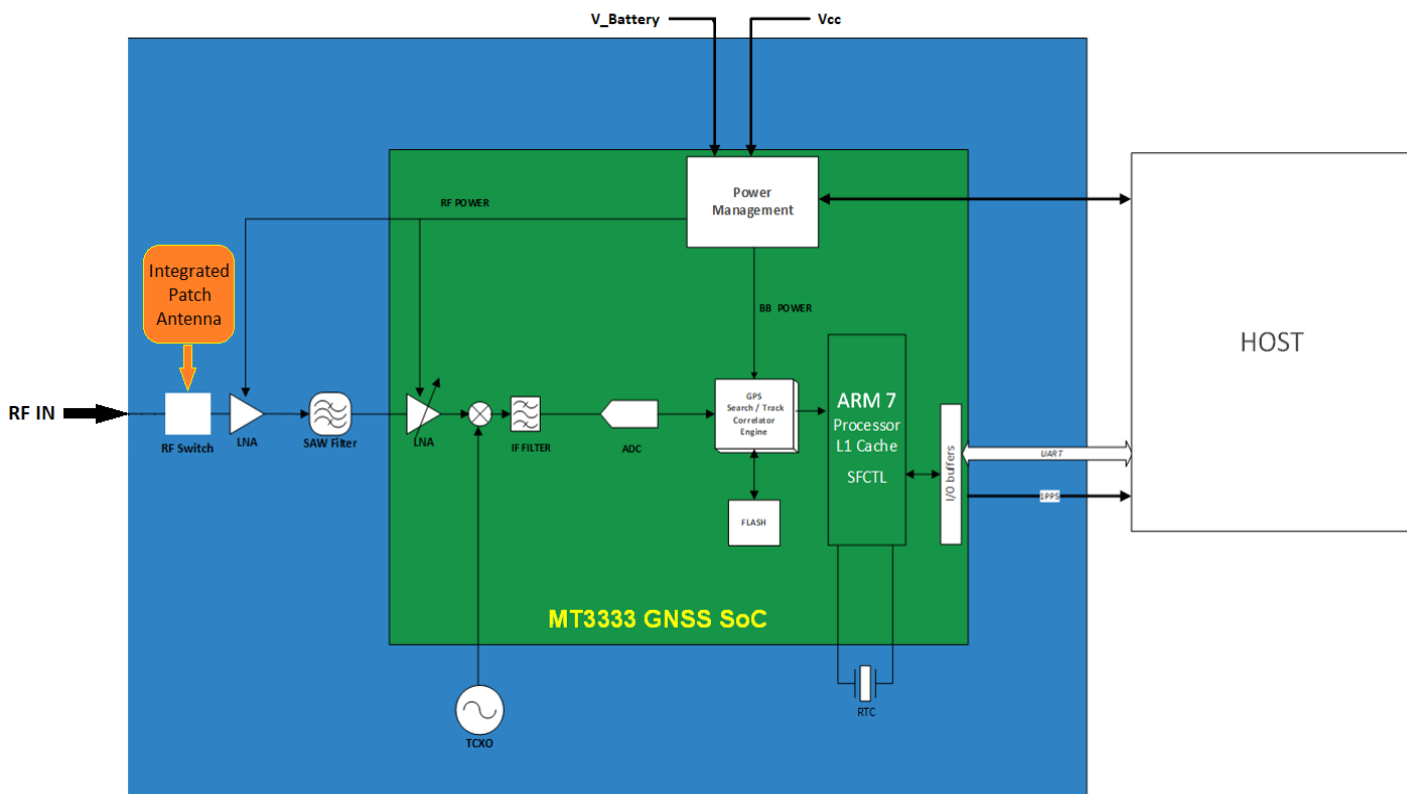

FIGURE 1 – ORG1518-MK06 ARCHITECTURE

- + **Antenna** OriginGPS proprietary Microstrip Patch Antenna collects GNSS signals from the outer space. Antenna is built from hi-Q ceramic element mounted on top of RF shield, providing stable resonance.
- + **RF switch** connects integrated antenna or external antenna to LNA corresponding to status of control signal.
- + **GNSS SAW Filter**
Band-Pass SAW filter attenuates out-of-band signals that may interfere to GNSS reception. GNSS SAW filter is optimized for low insertion loss in GNSS band and low return loss outside it.
- + **GNSS LNA**
Dual-stage cascaded LNAs amplify GNSS signals to meet RF down converter input threshold. Noise Figure optimized design was implemented to provide maximum sensitivity.
- + **TCXO**
Highly stable 26MHz temperature compensated oscillator controls down-conversion process in RF block of the GNSS SoC.
Characteristics of this component are important factors for higher sensitivity, shorter TTFF and better navigation stability.
- + **RTC crystal**
RTC 32.768 kHz quartz crystal with very tight specifications is necessary for maintaining Hot Start and Warm Start capabilities of the module.
- + **RF Shield**
RF enclosure avoids external interference from compromising sensitive circuitry inside the module. RF shield also blocks module's internal high frequency emissions from being radiated.

+ MT3333 GNSS SoC

The MT3333, multi-GNSS System on Chip designed by MediaTek, which is the world's leading digital media solution provider and largest fab-less IC Company in Taiwan.

It is a hybrid positioning processor that combines GPS, GLONASS, GALILEO, BEIDOU, SBAS, QZSS, DGPS and AGPS to provide a high-performance navigation solution.

MT3333 is a full SoC built on a low-power RF CMOS, incorporating GNSS RF, GNSS baseband, integrated navigation solution software, ARM® processor and serial flash.

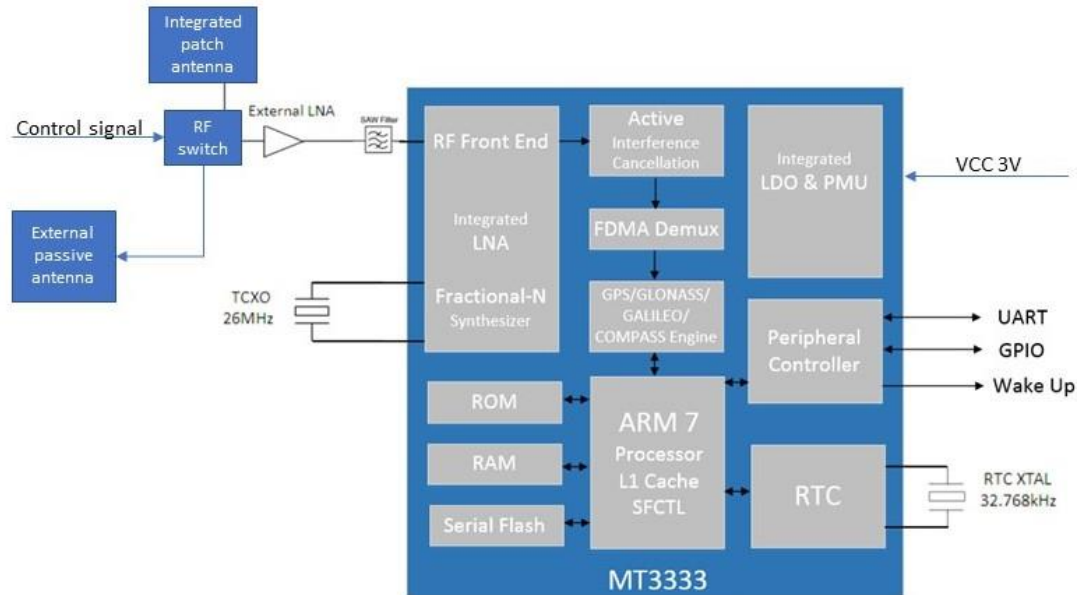

FIGURE 2 – ORG1518-MK06 SYSTEM BLOCK DIAGRAM AND PERIPHERAL

MT3333 SoC includes the following units:

- + GNSS radio subsystem containing single input dual receive paths for concurrent GPS, GLONASS and Galileo or GPS and BEIDOU, mixer with current mode interface between the mixer and multi-modes low pass filter, fractional-N synthesizer, integrated self-calibrating filters, IF VGA with AGC, high-sample rate ADCs with adaptive dynamic range.
- + Measurement subsystem including DSP core for GNSS signals acquisition and tracking, interference scanner and detector, interference removers, multipath and cross-correlation detectors, dedicated DSP code ROM and DSP cache RAM.
- + Measurement subsystem interfaces GNSS radio subsystem.
- + Navigation subsystem comprising ARM7® microprocessor system for position, velocity and time solution, program ROM, data RAM, cache and patch RAM and SPI flash.
- + Peripheral Controller subsystem containing UART Host interface, RTC block, wake up signal option, and GPIO.
- + Peripheral Controller subsystem interfaces navigation subsystem, PLL and PMU subsystems.
- + Navigation subsystem interfaces measurement subsystem.
- + PMU subsystem containing voltage regulators for RF and baseband domains.

12.3. ORG1518-MK06 FEATURES DESCRIPTION:

12.3.1 CONSTELLATION CONFIGURATION

- GPS, GLONASS and GALILEO – default since 28.5.2017.
- GPS and GLONASS- default (prior to 28.5.2017).
- GPS and BEIDOU- available.

For ordering this option contact sales@origingps.com

12.3.2 1PPS

1PPS (Pulse Per Second) signal output available on configuration:

- At 2D Fix only.
- At 3D Fix only.
- After the first Fix
- Always- default configuration.

For ordering other 1PPS options contact sales@origingps.com

The pulse is configurable for required duration, frequency and active high/low via command.

The pulse may vary 30nS (1 σ). The relationship between the PPS signal and UTC is unspecified.

12.3.3 Static Navigation

Static Navigation is an operational mode in which the receiver will freeze the position fix when the speed falls below a threshold (indicating that the receiver is stationary). The course is also frozen, and the speed is reported as 0. The navigation solution is then unfrozen when the speed increases above a threshold. The speed threshold can be set via a command (PMTK 386).

Static Navigation is disabled by default but can be enabled by command. This feature is useful for applications in which very low dynamics are not expected, the classic example being an automotive application.

12.3.4 Assistid GPS (AGPS)

Assisted GPS (or Aided GPS) is a method by which TTFF is reduced using information from a source other than broadcast GPS signals. The necessary ephemeris data is calculated either by the receiver itself (locally-generated ephemeris) or a server (server-generated ephemeris) and stored in the module.

ORG1518-MK06 has EASY, EPO and HotStill technology to allow for Hot Starts even in weak signal conditions and moving start-ups. EPO (Extended Prediction Orbit) is one of MediaTek's innovative proprietary off-line server based AGPS solution. Host could use an application to store and load the EPO files into device. With multi-constellation EPO, the user experience will be enhanced by the improved Time To First Fix (TTFF) and better first fix accuracy.

12.3.4.1 Locally-generated AGPS (Embedded Assist System – EASY)

The EASY™ is embedded assist system for quick positioning, the GPS engine will calculate and predict automatically the single ephemeris (Max. up to 3 days) when power on, and save the predict information into the memory, GPS engine will use these information for positioning if no enough information from satellites, so the function will be helpful for positioning and TTFF improvement under indoor or urban condition.

Up to 3 days extension for single received ephemeris:

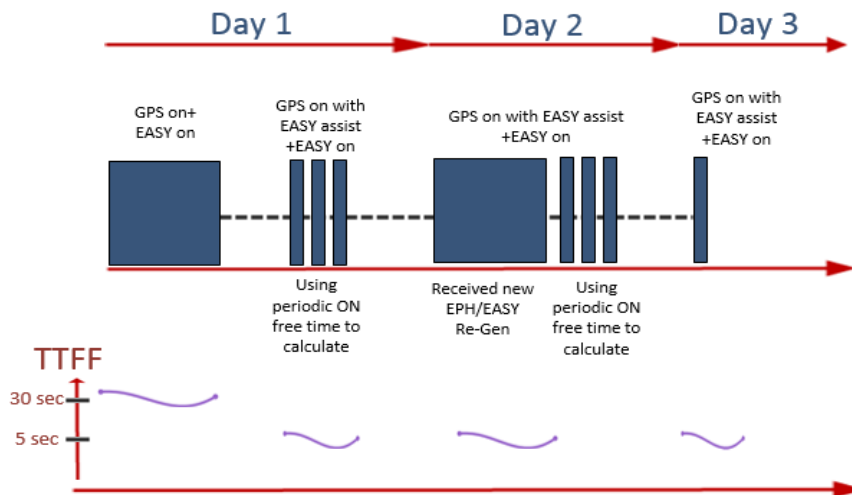

FIGURE 3 – EASY™ TTFF TIMING

12.3.4.2 Server-generated AGPS (Extended Prediction Orbit – EPO)

The AGPS (EPO™) supply the predicated Extended Prediction Orbit data to speed TTFF, users can download the EPO data to their GNSS engine from the FTP server by internet or wireless network, the GNSS engine will use the EPO data to assist position calculation when the navigation information of satellites are not enough or weak signal zone .

Host could use an application to store and load the EPO files into device. With multi-Constellation EPO, the user experience will be enhanced by the improved Time To First Fix (TTFF) and better first fix accuracy. The predicted ephemeris file is obtained from the AGPS server and is injected into the module over serial port 1 (RX1). These predictions do not require local broadcast ephemeris collection, and they are valid for up to 14 days.

12.3.4.3 HotStill – EASY (Extended Prediction Orbit)

HotStill (EASY) is one of MTK's innovative proprietary Off-line client-based A-GPS solution which could greatly accelerate GPS TTFF (Time to First Fix) in urban canyon or weak signal environment from several minutes to only few seconds. It works as a background software running on the host processor to predicate satellite orbit navigation data and generate Broadcast Ephemeris Extension (BEE) from received broadcast ephemeris as well as no network connection requirements. Hotstill feature is designed for use on smartphones and it's not suitable for standalone designs.

12.3.5 Quasi-Zenith Satellite System (QZSS)

The three satellites of the Japanese SBAS are in a highly-inclined elliptical orbit which is geosynchronous (not geostationary) and has analemma-like ground tracks. This orbit allows continuous coverage over Japan using only three satellites. Their primary purpose is to provide augmentation to the GPS system, but the signals may also be used for ranging. NMEA reporting for QZSS may be enabled/disabled by the user.

12.3.6 Satellite-Based Augmentation System (SBAS)

The ORG1518-MK06 receiver is capable of using Satellite-Based Augmentation System (SBAS) satellites as a source of both differential corrections and satellite range measurements. These systems (WAAS, EGNOS, MSAS, and GAGAN) use geostationary satellites to transmit regional differential corrections via a GNSS-compatible signal. The use of SBAS corrections can significantly improve position accuracy and its enabled by default.

12.3.7 Diferencial GPS (DGPS)

DGPS is a Ground-Based Augmentation System (GBAS) for reducing position errors by applying corrections from a set of accurately-surveyed ground stations located over a wide area. These reference stations measure the range to each satellite and compare it to the known-good range. The differences can then be used to compute a set of corrections which are transmitted to a DGPS receiver, either by radio or over the internet. The DGPS receiver can then send them to the serial port 1 (RX1) using the RTCM SC-104 message protocol. The corrections can significantly improve the accuracy of the position reported to the user. The receiver can accept either the RTCM SC-104 messages or SBAS differential data.

12.3.8 Jamming Rejection – Active Interference Cancellation (AIC)

The ORG1518-MK06 detect, track and removes narrow-band interfering signals (jamming signals) without the need for external components or tuning. It tracks and removes up to 12 CW (Continuous Wave) type signals up to -80 dBm (total power signal levels). By default, the jamming detection is enabled but can be disabled by command. This feature is useful both in the design stage and during the production stage for uncovering issues related to unexpected jamming. When enabled, AIC will increase current consumption by about 1 mA. Impact on GNSS performance is minimal at low jamming levels, however at high jamming levels (e.g. -90 to -80 dBm), the RF signal sampling ADC starts to become saturated after which the GNSS signal levels start to diminish.

12.3.9 Power Management Modes

The ORG1518-MK06 support operational modes that allow them to provide positioning information at reduced overall current consumption. Availability of GNSS signals in the operating environment will also be a factor in choice of power management modes. The designer can choose a mode that provides the best trade-off of performance versus power consumption.

The power management modes are described below, and can be enabled via command:

- **Full Power Continuous- for best GNSS performance**
- **Power save mode to optimize power consumption:**
 - **Standby**
 - **Periodic**
 - **AlwaysLocate™**
- **Backup mode**

12.3.9.1 Full Power Continuous Mode

The modules start up in full power continuous mode. This mode uses the acquisition engine at full performance resulting in the shortest possible TTFF and the highest sensitivity. It searches for all possible satellites. The receiver then switches to the tracking engine to lower the power consumption when:

- A valid GPS/GNSS position is obtained
- The ephemeris for each satellite in view is valid

To return to Full Power mode (from a low power mode), send the following command: **PMTK225,0** [Just after the module wakes up from its previous sleep cycle].

12.3.9.2 Standby Mode

In this mode, the receiver stops navigation, the internal processor enters standby state, and the current drain at main supply (VCC) is reduced. Standby mode is entered by sending only one of the following commands: **PMTK161,0 – Standby stop mode = turn off VTXCO, RF and baseband.**

PMTK161,1 - Standby sleep mode = turn off RF and baseband.

The host can then wake up the module from Standby mode to Full Power mode by sending any byte to the serial port.

Please notice it is not possible to wake up the module from Standby Mode via I2C interface.

In case you are using **I2C** interface – please use Backup mode (see page 19 – section 12.3.9.5).

It is possible to exit from backup mode to active mode only via hardware- by applying high signal on Force_On pad.

12.3.9.3 Periodic Mode

This mode allows autonomous power on/off with reduced fix rate to reduce average power consumption. In periodic mode, the main power supply VCC is still powered, but power distribution to internal circuits is controlled by the receiver.

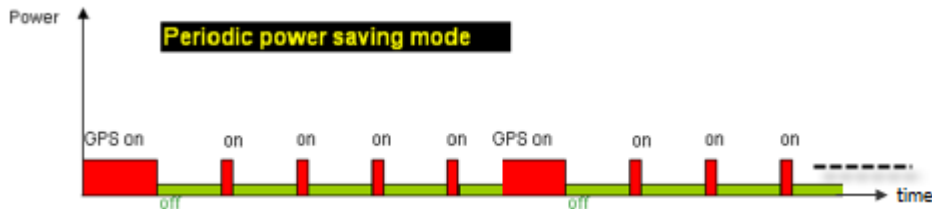

FIGURE 4 – PERIODIC POWER SAVING MODE

Enter periodic mode by sending the following command:

```
PMTK225,<Type>,<Run_time>,<Sleep_time>,<2nd_run_time>,<2nd_sleep_time>*<checksum>
```

Where:

- Type = 1 for Periodic backup mode,
Type = 2 for Periodic standby mode
- Run_time = Full Power period (ms)
- Sleep_time = Standby period (ms)
- 2nd_run_time = Full Power period (ms) for extended acquisition if GNSS acquisition fails during Run_time.
- 2nd_sleep_time = Standby period (ms) for extended sleep if GNSS acquisition fails during Run_time

Example: **PMTK225,2,3000,12000,18000,72000**

for periodic mode with 3 s navigation and 12 s sleep. The acknowledgement response for this command is: **PMTK001,225,3**

Periodic mode is exited back to Full Power Continuous Mode by sending the command: **PMTK225,0** just after the module wakes up from a previous sleep cycle.

12.3.9.4 AlwaysLocate™ Mode

AlwaysLocate™ is an intelligent controller of the Periodic mode; the main power supply VCC is still powered up, but power distribution is internally controlled. Depending on the environment and motion conditions, the module can autonomously and adaptively adjust the parameters of the Periodic mode, e.g. ON/OFF ratio and fix rate to achieve a balance in positioning accuracy and power consumption. The average current can vary based on conditions.

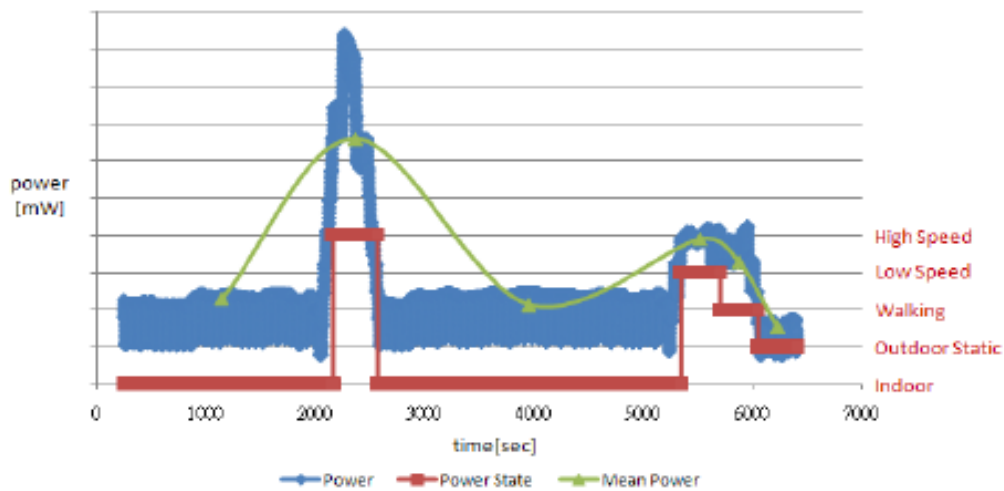

FIGURE 5 – AlwaysLocate™ MODE: POWER VS. TIME

Enter AlwaysLocate™ mode by sending the following NMEA command:

PMTK225,<mode>*<checksum><CR><LF>

Where: mode=9 for AlwaysLocate™

Example:

PMTK225,9

The acknowledgement response for the command is:

PMTK001,225,3

The user can exit low power modes to Full Power by sending NMEA command:

PMTK225,0

Just after the module wakes up from its previous sleep cycle.

12.3.9.5 Backup Mode

Backup Mode means a low quiescent power state where receiver operation is stopped.

V_backup is powered ON but the current consumption is minimal.

After waking up, the receiver uses all internal aiding, including GNSS time, Ephemeris, and Last Position, resulting in the fastest possible TTFF in either hot or warm start modes.

During backup State, the I/O block is powered off. The suggestion is that the host forces its outputs to a low state or to a high-Z state during the Backup State to minimize small leakage currents at receiver's input signals.

The Current consumption is ~12uA in BACKUP mode (VCC & V_BACKUP).

Entering Backup Mode:

First option

Entering to backup mode is done by a NMEA software command –
PMTK225,4 (+checksum).

Important: Before sending the command the FORCE_ON pin must be tied to ground.

While in Backup mode, the module will consume ~12uA from VCC & V_BACKUP.

In case the command is sent while the FORCE_ON is not tied to the ground – the module would get into idle state, but not BACKUP mode, and the current consumption would be significantly higher.

The Current consumption is ~12uA in BACKUP mode while FORCE_ON pin of module is tied to ground with jumper. In real cases FORCE_ON pin is grounded by active device with residue resistance differ from zero so current consumption may be 2-3 times higher i.e. 25uA.

FORCE_ON must be tied to ground if you need to stay in BACKUP mode.

Example:

PMTK225,4 Enter backup mode

NMEA Return feedback:

PMTK001,225,3

Module will stay in BACKUP mode while FORCE ON is tied to ground.

To Exit from BACKUP mode, disconnect FORCE_ON from ground and pull the FORCE_On to high level wait about 1 sec and then release it to logic low again.

Important: It is not possible to wake up the module from backup mode by software command.

Second option

Entering the BACKUP mode is done by disconnecting VCC and keeping the V_backup connected. The module will consume 7uA from V_backup. Ones the VCC is connected again, wait about 1 sec and then release it to logic low again, the module would switch into active state and acquire a hot start.

12.3.10 Configuration settings

Currently, the configuration settings will be erased after turning down the power.

Be aware to this issue on power cycles while shutting down the module.

12.4 PADS ASSIGNMENT – ORG1518-MK06

PAD	NAME	FUNCTION	DIRECTION	Logic level
1	RX	UART Receive (Serial Input)	Input	2.8 V
2	TX	UART Transmit (Serial Output)	Output	2.8V
3	V BACKUP	Input for battery backup	Input power	2.8-4.2V
4	SCK	SPI clock	Input /Output	2.8 V
5	SCS	SPI chip selects	Input /Output	2.8V
6	MISO	Master input slave output	Input /Output	2.8V
7	CTRL	LOW integrated antenna / HIGH for external antenna	Input	2.8V
8	VCC	System Power	Input Power	3.3V
9	MOSI	Master output slave input	Input /Output	2.8V
10	GND	System Ground		
11	GND	System Ground		
12	GND	System Ground		
13	RF	RF input from external antenna	Input	-
14	GND	System Ground		
15	WAKEUP	WAKEUP	Output	2.8 V
16	RESET	System Reset– Active Low	input	2.8V
17	FORCE_ON	Forced full-power mode signal – Active Low	Input	2.8 V
18	CTS	UART Clear To Send/I2C Clock	Input /Output	2.8 V
19	RTS	UART Ready To Send/I2C Data	Input /Output	2.8V
20	EINT	EXTERNAL INTERRUPT	Output	2.8 V
21	1PPS	UTC Time Mark	Output	2.8 V
22	FIX	FIX LED	Output	2.8V

TABLE 3 – ORG1518-MK06 PIN-OUT

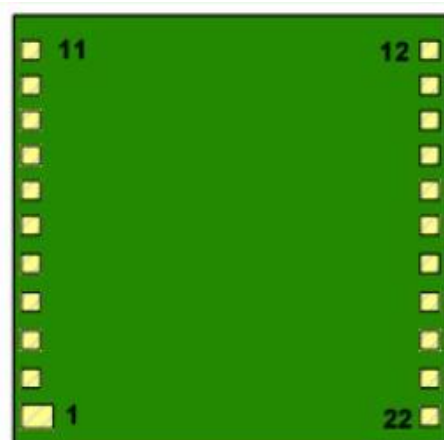

FIGURE 8 – FOOTPRINT

13. MECHANICAL SPECIFICATIONS

- + ORG1518 module has advanced ultra-miniature LGA SMD packaging sized 17mm x 17mm.
- + ORG1518 built on a PCB assembly enclosed with metallic RF shield box and antenna element on top of it.
- + There are 22 castellated LGA SMT pads made Cu base and ENIG plating on bottom side.

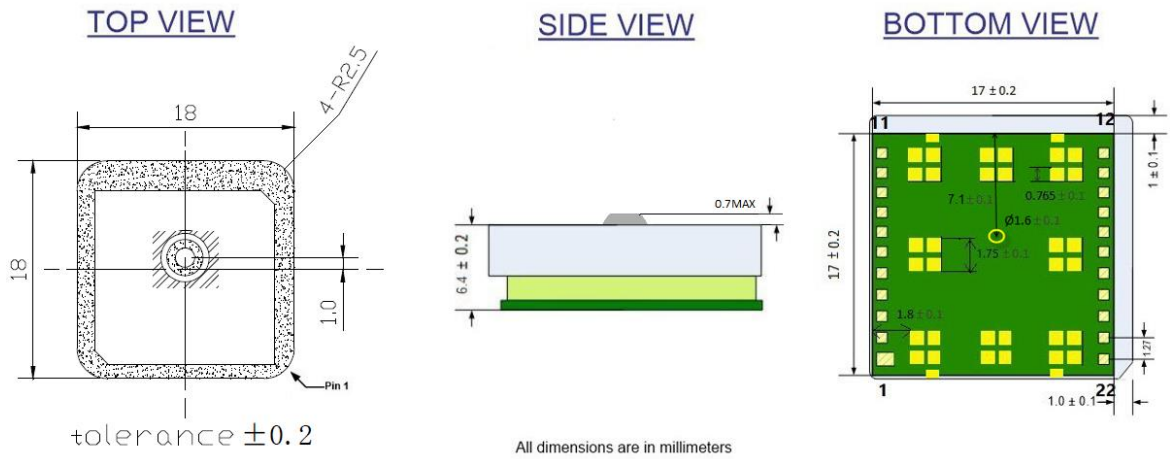

FIGURE 7 – MECHANICAL DRAWING

Dimensions	Length	Width	Height	Weight	
mm	17.00 +0.20/ -0.10	17.00 +0.20/ -0.10	6.70 +0.20/ -0.20	g	8
inch	0.669 +0.008/ -0.004	0.669 +0.008/ -0.004	0.264 ± 0.008	oz	0.28

TABLE 4 – MECHANICAL SUMMARY



14. ELECTRICAL SPECIFICATIONS

14.1. ABSOLUTE MAXIMUM RATINGS

Stresses exceeding Absolute Maximum Ratings may damage the device.

PARAMETER	SYMBOL	MIN	MAX	UNIT
Power Supply Voltage	V_{CC}	-0.30	+4.3	V
Backup Battery Supply Voltage	V_{backup}	-0.30	+4.3	V
Power Supply Current ¹	I_{CC}		120	mA
RF Input power	V_{RF}		0	dBm
I/O Voltage	V_{IO}	-0.30	+3.6	V
I/O Source/Sink Current	I_{IO}		+8	mA
ESD Voltage	$V_{IO/RF, HBM Model}^3$	(-/+) 1000	(-/+) 3000	V
	$V_{IO/RF, MM Model}^4$	(-/+) 100	(-/+) 300	V
Operating Temperature	T_{AMB}	-45	+90	°C
Storage Temperature	T_{ST}	-50	+125	°C
Lead Temperature ⁴	T_{LEAD}	-5	+260	°C

TABLE 5 – ABSOLUTE MAXIMUM RATINGS

Notes:

1. Inrush current of up to 100mA for about 20 μ s duration.
2. Human Body Model (HBM) contact discharge per EIA/JEDEC JESD22-A114D. Step: 500V (+/-).
3. Machine Model (MM) contact discharge per EIA/JEDEC JESD22-A115C. Step: 50V (+/-).
4. Lead temperature at 1mm from case for 10s duration.

14.2. RECOMMENDED OPERATING CONDITIONS

Exposure to stresses above Recommended Operating Conditions may affect device reliability.

PARAMETER	SYMBOL	MODE / PAD	TEST CONDITIONS	MIN	TYP	MAX	UNIT	
Power supply voltage	V _{CC}	V _{CC}		+3.00	+3.3	+3.60	V	
Backup Battery supply voltage	V _{backup}	V _{backup}		+2.80	+3.60	+4.20	V	
Digital IO Pin Low level input voltage	V _{il}			-0.3		+0.7	V	
Digital IO Pin High level input voltage	V _{ih}			+2.1		+3.6	V	
Digital IO Pin Low level output voltage	V _{ol}		I _{ol} =2mA	-0.3		+0.4	V	
Digital IO Pin High level output voltage	V _{oh}		I _{oh} =2mA	+2.4	+2.8	+3.1	V	
Power Supply Current ¹	I _{CC}	Acquisition	GPS		40		mA	
			GPS+GLONASS		45		mA	
		Tracking	GPS		28		mA	
			GPS+GLONASS		35		mA	
		Standby				0.5		mA
		Backup			7	12	25	μA
Input Impedance	Z _{IN}	RF Input	f _{IN} = 1575.5MHz		50		Ω	
Input Return Loss	R _{LIN}			-7			dB	
Input Power Range	P _{IN}		GPS or GLONASS	-165		-110	dBm	
Input Frequency Range	f _{IN}			1560		1607	MHz	
Operating Temperature	T _{AMB}			-40	+25	+85	°C	
Storage Temperature ²	T _{ST}			-50	+25	+125	°C	
Relative Humidity ³	R _H		T _{AMB}	5		95	%	

TABLE 6 – RECOMMENDED OPERATING CONDITIONS

Notes:

1. Typical values under static signal conditions of -130dBm and ambient temperature of +25°C and low gain configuration.
2. Longer TTF is expected while operating below -30°C to -40°C.
3. Relative Humidity is within Operating Temperature range.



15. PERFORMANCE

15.1. ACQUISITION TIME

TTF (Time To First Fix) – is the period of time from module’s power-up till valid position estimation.

15.1.1. HOT START

Hot Start results either from a software reset after a period of continuous navigation or a return from a short idle period that was preceded by a period of continuous navigation.

During Hot Start all critical data (position, velocity, time, and satellite ephemeris) is valid to the specified accuracy and available in RAM.

15.1.2. SIGNAL REACQUISITION

Reacquisition follows temporary blocking of GNSS signals.

Typical reacquisition scenario includes driving through tunnel.

15.1.3. AIDED START

Aided Start is a method of effectively reducing TTF by providing valid satellite ephemeris data.

Aiding can be implemented using Embedded Assist System (EAS) and Extended Prediction Orbit (EPO).

15.1.4. WARM START

Warm Start typically results from user-supplied position and time initialization data or continuous RTC operation with an accurate last known position available in RAM.

In this state position and time data are present and valid, but satellite ephemeris data validity has expired.

15.1.5. COLD START

Cold Start occurs when satellite ephemeris data, position and time data are unknown.

Typical Cold Start scenario includes first power application.

OPERATION ¹	MODE	VALUE	UNIT
Hot Start		< 1	s
Aided Start ³		< 3	s
Warm Start	GPS + GLONASS	< 23	s
	GPS	< 29	s
Cold Start	GPS + GLONASS	< 23	s
	GPS	< 31	s
Signal Reacquisition ²		< 3	s

TABLE 7 – ACQUISITION TIME

Notes:

1. EVK is 24-hrs. Static under signal conditions of -130dBm and ambient temperature of +25°C.
2. Outage duration ≤ 30s.
3. Dependent on aiding data connection speed and latency

15.2. SENSITIVITY

15.2.1. TRACKING

Tracking is an ability of receiver to maintain valid satellite ephemeris data.

During tracking receiver may stop output valid position solutions.

Tracking sensitivity defined as minimum GNSS signal power required for tracking.

15.2.2. REACQUISITION

Reacquisition follows temporary blocking of GNSS signals.

Reacquisition sensitivity defined as minimum GNSS signal power required for reacquisition.

15.2.3. NAVIGATION

During navigation receiver consequently, outputs valid position solutions.

Navigation sensitivity defined as minimum GNSS signal power required for reliable navigation.

15.2.4. HOT START

Hot Start sensitivity defined as minimum GNSS signal power required for valid position solution under Hot Start conditions.

15.2.5. AIDED START

Aided Start sensitivity defined as minimum GNSS signal power required for valid position solution following aiding process.

15.2.6. COLD START

Cold Start sensitivity defined as minimum GNSS signal power required for valid position solution under Cold Start conditions, sometimes referred as ephemeris decode threshold.

OPERATION ¹	MODE	VALUE	UNIT
Tracking	GPS	-165	dBm
	GLONASS	-165	dBm
Navigation	GPS	-163	dBm
	GLONASS	-163	dBm
Reacquisition ²	GPS+GLONASS	-160	dBm
Hot Start	GPS+GLONASS	-163	dBm
Aided Start	GPS+GLONASS	-160	dBm
Cold Start	GPS+GLONASS	-148	dBm

TABLE 8 – SENSITIVITY

** The above values have been tested at update rate of 1 Hz.

15.3. RECEIVED SIGNAL STRENGTH

PARAMETER ⁴	VALUE	UNIT
C/N ₀	45	dB-Hz

TABLE 9 – RECEIVED SIGNAL STRENGTH

Notes:

1. EVK is static, ambient temperature is +25°C.
2. Outage duration ≤ 30s.
3. Aiding using Broadcast Ephemeris (Ephemeris Push™) or Extended Ephemeris (CGEE™ or SGEE™).
4. Average C/N₀ reported for 4 SVs, EVK is 24-hrs. Static, outdoor, ambient temperature is +25°C.

15.4. POWER CONSUMPTION

OPERATION ¹	MODE	VALUE	UNIT
Acquisition	GPS	132	mW
	GPS + GLONASS	148.5	mW
Tracking	GPS	92.4	mW
	GPS + GLONASS	115.5	mW
Standby state		1.65	mW
Backup state		39.6	uW

TABLE 10 – POWER CONSUMPTION

Note:

1. Typical values under static signal conditions of -130dBm and ambient temperature of +25°C. Measured voltage= 3.28V.

15.5. POSITION ACCURACY

Parameter	Constellation	CEP ¹ (m)
Horizontal Position Accuracy	GPS	2.5
Horizontal Position Accuracy	Glonass	2.6
Horizontal Position Accuracy	BeiDou	10.2
Horizontal Position Accuracy	GPS + Glonass	2.5
Horizontal Position Accuracy	GPS + BeiDou	2.5

TABLE 11 – ORG1518-MK06 POSITION ACCURACY

Notes:

1. Module is static under signal conditions of -130dBm, ambient temperature is +25°C.

15.6. DYNAMIC CONSTRAINS

PARAMETER	Metric	Imperial
Velocity	515m/s	1,000knots
Altitude ¹	10,000m	32808ft
Altitude Balloon mode	80,000m	262,467ft
Acceleration	4g	

TABLE 12 – DYNAMIC CONSTRAINS

Note:

1. In Normal / Fitness / Aviation modes the Altitude limitation is 10000 m. In Balloon mode it's 80000 m.

16. INTERFACE

16.1. POWER SUPPLY

It is recommended to keep the power supply on all the time in order to maintain RTC block active and keep satellite data in RAM for fastest possible TTFF. When V_{CC} is removed, settings are reset to factory default and the receiver performs Cold Start on next power up.

16.1.1. Nominal VCC = 3.3V

V_{CC} is 3.3v DC and must be provided from regulated power supply.

During tracking the processing is less intense compared to acquisition, therefore power consumption is lower.

Filtering is important to manage high alternating current flows on the power input connection.

An additional LC filter on ORG1518-MK06 power input may be needed to reduce system noise.

The high rate of ORG1518-MK06 input current change requires low ESR bypass capacitors.

Additional higher ESR output capacitors can provide input stability damping.

The ESR and size of the output capacitors directly define the output ripple voltage with a given inductor size. Large low ESR output capacitors are beneficial for low noise.

16.1.2. GROUND

Ground pad must be connected to host PCB Ground with shortest possible trace or/and by multiple VIAs.

16.2. CONTROL INTERFACE

Multi Hornet ORG1518-MK06 has a three host interfaces: UART, I2C and SPI.

The switching between the interfaces is by firmware update.

16.2.1 UART- HOST INTERFACE

Multi Hornet ORG1518-MK06 has a standard UART port:

16.2.1.1 TX

TX used for GPS data reports. Output logic high voltage level is 2.8V.

The TX serial data line outputs NMEA serial data at a default bit rate of 9600 bps.

When no serial data is being output the TX data line idles high.

16.2.1.2 RX

RX used for receiver control. Input logic high voltage level is 2.8V.

The RX data line accepts NMEA commands at a default bit rate of 9600 bps.

When the receiver is powered down, do not back drive this or any other GPIO line.

The idle state for serial data from the host computer is logic 1.

16.2.2 I2C- HOST INTERFACE

ORG1518-MK06 has a standard I2C interface.

I2C interface is enabled by default starting from F.W version 5.1.1.

I2C host interface features are:

- I2C Slave mode – host initiates clock and data, operating speed 400kbps.
- ORG1518-MK06 support 7 bit I2C address.
- I2C default slave address '0x10'.
- Individual Tx FIFO buffer length of 255 bytes. Master can read one I2C data packet of max. 255 bytes at a time.
- In order to read entire NMEA packet of one second, master need to read several I2C data packets and extract valid NMEA data. After reading one I2C data packet, sleep 2ms before reading the next packet. In case entire packet of 1 second was read, wait for a longer period for the next NMEA packet.

16.3. HARDWARE INTERFACE

16.3.1 FORCE-ON

Entering into BACKUP mode by sending SW command and tied to ground the FORCE_ON pin.

FORCE_ON must be tied to ground in order to stay in BACKUP mode.

Module will stay in BACKUP mode while FORCE ON is tied to ground.

To Exit from BACKUP mode, disconnect FORCE_ON from ground and force full power.

When inactive, it should be floating.

16.3.2 RESET

In addition, to NMEA command for reset- \$PMTK104*37, external reset is available through $\overline{\text{RESET}}$ pad. Active low signal. Signal logic level of 2.8V.

16.3.3 1PPS

Pulse-Per-Second (PPS) output provides a pulse signal for timing purposes.

The pulse is configurable for required duration, frequency and active high/low via command.

The pulse may vary 30 nS (1 σ). The relationship between the PPS signal and UTC is unspecified.

Use Proprietary Mediatek command PMTK255 to enable or disable this functionality:

- **PMTK255,1 => enable PPS**
- **PMTK255,0 => disable PPS**

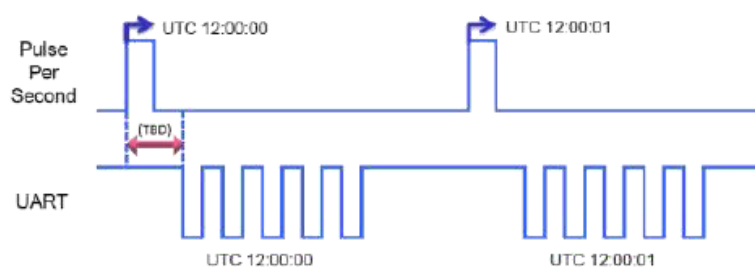

FIGURE 8 – 1PPS AND UTC

1PPS supports 1Hz NMEA output, but at baud rate of 9600 bps, if there are many NMEA sentences output, per second transmission may exceed one second.

16.3.4 WAKEUP

When the ORG1518-MK06 is on (full power) the output will be high at ~2.5V level.

When the ORG1518-MK06 is on Standby or backup mode the output will be low (ground).

On low power modes (Periodic and AlwaysLocate) when the ORG1518-MK06 is off the wakeup level is low (and the wakeup returns to high level when the module returns to full power).

The Wakeup output is designed only for probing to determine if the module is in active mode or in standby/backup states. Depending on the type of the probe there might be a possible influence on the voltage high level.



20. COMMANDS DESCRIPTION

Command ID	Description
PMTK000	Test. This command will be echoed back to the sender (for testing the communications link).
PMTK101	Perform a HOT start
PMTK102	Perform a WARM start
PMTK103	Perform a COLD start
PMTK104	Perform a system reset (erasing any stored almanac data) and then a COLD start
PMTK120	Erase aiding data stored in flash memory
PMTK127	Erase EPO data stored in flash memory
PMTK161,0	Standby - Stop mode
PMTK161,1	Standby - Sleep mode
PMTK251,Baudrate	Set NMEA Baudrate
PMTK313,0	Disable SBAS feature
PMTK313,1	Enable SBAS feature
PMTK353,1,0,0,0,0	Enable GPS only mode
PMTK353,0,1,0,0,0	Enable GLO only mode
PMTK353,0,0,0,0,1	Enable BDS only mode
PMTK353,1,1,0,0,0	Enable GPS and GLO mode
PMTK353,1,0,0,0,1	Enable GPS and BDS mode

TABLE 13– NMEA INPUT COMMANDS

21. FIRMWARE UPDATES

The FW stored in the internal Flash memory may be upgraded via the (UART) serial port TX/RX pads. In order to update the FW, the following steps should be performed to perform reprogramming:

1. Remove all power to the module.
2. Connect serial port to a PC.
3. Apply main power.
4. Run the software utility to re-flash the module. Clearing the entire flash memory is strongly recommended prior to programming.
5. Upon successful completion of re-flashing, remove main power to the module for a minimum of 10 seconds.
6. Apply main power to the module.
7. Verify the module has returned to the normal operating state.

22. HANDLING INFORMATION

22.1. MOISTURE SENSITIVITY

ORG1518-MK06 modules are MSL 3 designated devices according to IPC/JEDEC J-STD-033B standard. Module in sample or bulk package should be baked prior to assembly at 125°C for 48 hours.

22.2. ASSEMBLY

The module supports automatic pick-and-place assembly and reflow soldering processes. Suggested solder paste stencil is 5 mil to ensure sufficient solder volume.

22.3. SOLDERING

Reflow soldering of the module always on component side (Top side) of the host PCB according to standard IPC/JEDEC J-STD-020D for LGA SMD.

Avoid exposure of ORG1518-MK06 to face-down reflow soldering process.

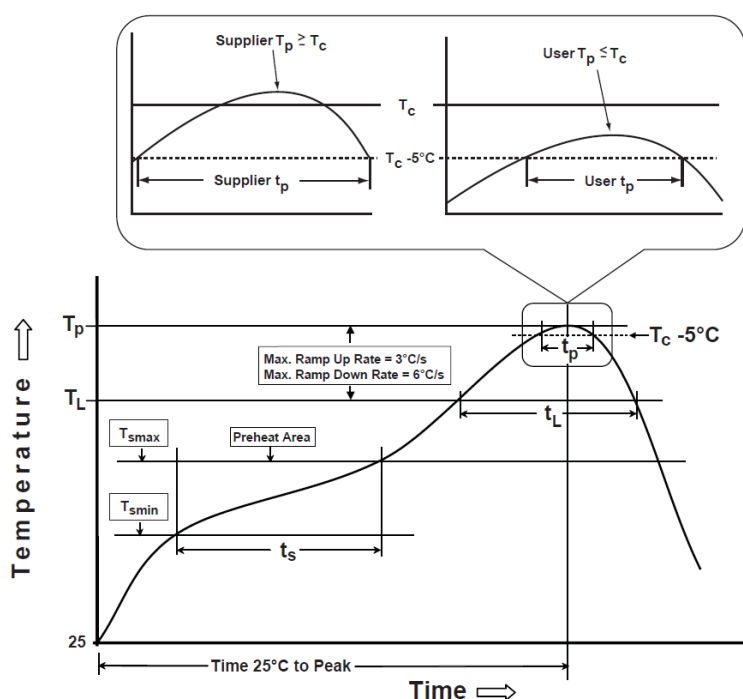

FIGURE 10 – RECOMMENDED SOLDERING PROFILE

Referred temperature is measured on top surface of the package during the entire soldering process. Suggested peak reflow temperature is 250°C for 30 sec. for Pb-Free solder paste.

Actual board assembly reflow profile must be developed individually per furnace characteristics. Reflow furnace settings depend on the number of heating/cooling zones, type of solder paste/flux used, board design, component density and packages used.

SYMBOL	PARAMETER	MIN	TYP	MAX	UNIT
T _C	Classification Temperature		250		°C
T _P	Package Temperature			250	°C
T _L	Liquidous Temperature		217		°C
T _S	Soak/Preheat Temperature	150		200	°C
t _s	Soak/Preheat Time	60		120	s
t _L	Liquidous Time	60		150	s
t _p	Peak Time		30		s

TABLE 14 – SOLDERING PROFILE PARAMETERS

22.4. CLEANING

If flux cleaning is required, module is capable to withstand standard cleaning process in vapor degreaser with the Solvon® n-Propyl Bromide (NPB) solvent and/or washing in DI water.

Avoid cleaning process in ultrasonic degreaser, since specific vibrations may cause performance degradation or destruction of internal circuitry.

22.5. REWORK

If localized heating is required to rework or repair the module, precautionary methods are required to avoid exposure to solder reflow temperatures that can result in permanent damage to the device.

22.6. ESD SENSITIVITY

This product is ESD sensitive device and must be handled with care.



22.7. SAFETY INFORMATION

Improper handling and use can cause permanent damage to the product.

22.8. DISPOSAL INFORMATION

This product must not be treated as household waste.

For more detailed information about recycling electronic components contact your local waste management authority.



23. COMPLIANCE

The following standards are applied on the production of ORG1518 modules:

- + IPC-6011/6012 Class2 for PCB manufacturing
- + IPC-A-600 Class2 for PCB inspection
- + IPC-A-610D Class2 for SMT acceptability

ORG1518-MK06 modules are manufactured in ISO 9001:2008 accredited facilities.

ORG1518-MK06 modules are manufactured in ISO 14001:2004 accredited facilities.

ORG1518-MK06 modules are manufactured in OHSAS 18001:2007 accredited facilities.

ORG1518-MK06 modules are designed, manufactured and handled in compliance with the Directive 2011/65/EU of the European Parliament and of the Council of June 2011 on the Restriction of the use of certain Hazardous Substances in electrical and electronic equipment, referred as RoHS II.

ORG1518-MK06 modules are manufactured and handled in compliance with the applicable substance bans as of Annex XVII of Regulation 1907/2006/EC on Registration, Evaluation, Authorization and Restriction of Chemicals including all amendments and candidate list issued by ECHA, referred as REACH.

ORG1518-MK06 modules comply with the following EMC standards:

- + EU CE EN55022:06+A1(07), Class B
- + US FCC 47CFR Part 15:09, Subpart B, Class B
- + JAPAN VCCI V-3/2006.04



24. PACKAGING AND DELIVERY

24.1. APPEARANCE

ORG1518 modules are delivered in reeled tapes for automatic pick and place assembly process.

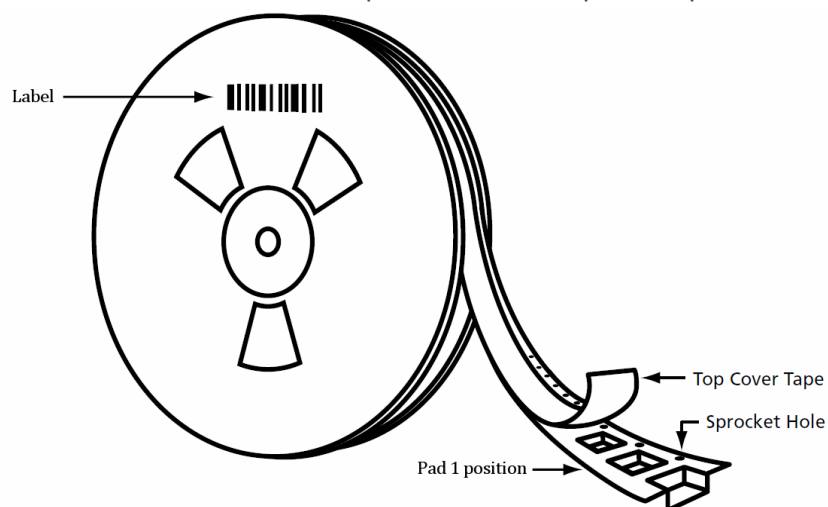

FIGURE 11 – MODULE POSITION

ORG1518 modules are packed in 2 different reel types.

SUFFIX	TR1	TR2
Quantity	150	300

TABLE 15 – REEL QUANTITY

Reels are dry packed with humidity indicator card and desiccant bag according to IPC/JEDEC J-STD-033B standard for MSL 3 devices.

Reels are vacuum sealed inside anti-static moisture barrier bags.

Sealed reels are labeled with MSD sticker providing information about:

- + MSL
- + Shelf life
- + Reflow soldering peak temperature
- + Seal date

Sealed reels are packed inside cartons.

Reels, reel packs and cartons are labeled with sticker providing information about:

- + Description
- + Part number
- + Lot number
- + Customer PO number
- + Quantity
- + Date code

24.2. CARRIER TAPE

Carrier tape material - polystyrene with carbon (PS+C).

Cover tape material – polyester based film with heat activated adhesive coating layer.

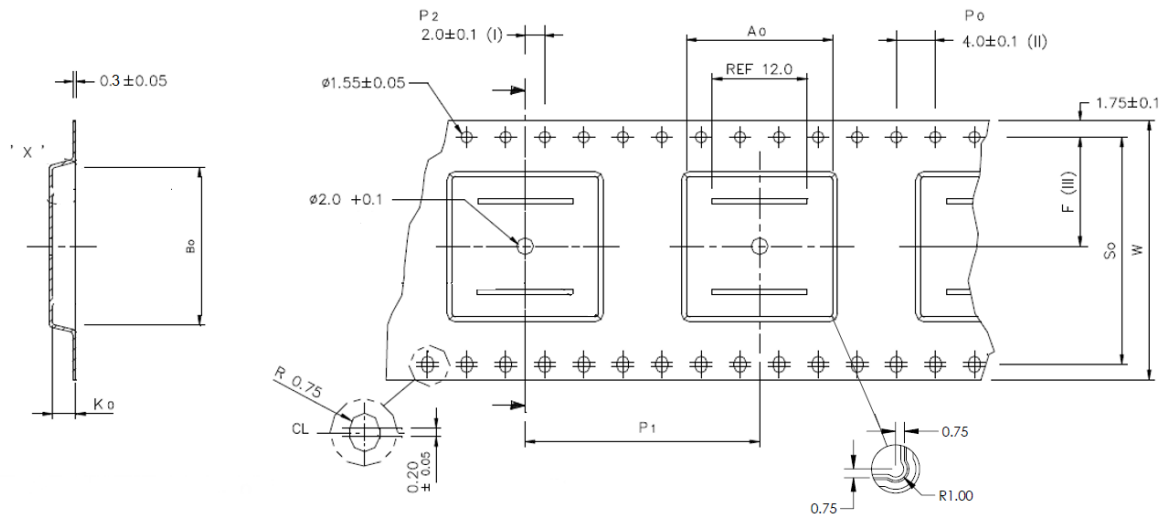

FIGURE 12 – CARRIER TAPE

	mm
A ₀	18.70 ± 0.2
B ₀	18.70 ± 0.2
K ₀	7.20 ± 0.2
F	14.20 ± 0.1
P ₁	24.00 ± 0.2
S ₀	28.40 ± 0.1
W	32.00 ± 0.3

TABLE 16 – CARRIER TAPE DIMENSIONS

24.3. REEL

Reel material - antistatic plastic.

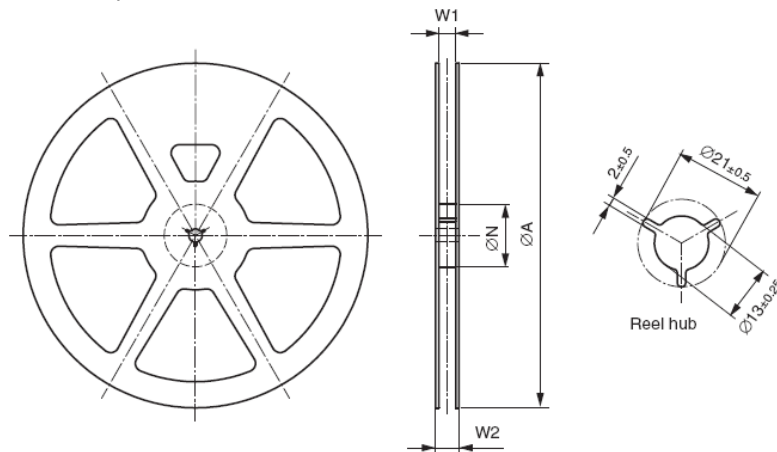

FIGURE 13 – REEL

SUFFIX	TR1	
	mm	inch
ØA	330.0 ± 2.0	13.00 ± 0.08
ØN	102.0 ± 2.0	4.02 ± 0.08
W1	16.7 ± 0.5	0.66 ± 0.02
W2	22.2 ± 0.5	0.87 ± 0.02

TABLE 17 – REEL DIMENSIONS

25. ORDERING INFORMATION

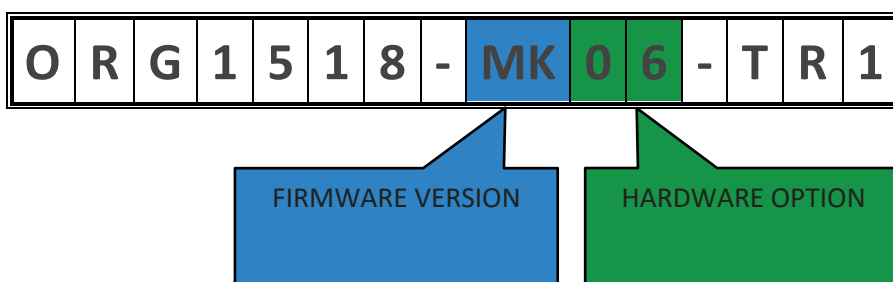

FIGURE 14 – ORDERING OPTIONS

PART NUMBER	FW VERSION	HW OPTION	V _{CC} RANGE	PACKAGING	SPQ
ORG1518-MK06-TR1	MK	06	3.3V	REELED TAPE	150
ORG1518-MK06-TR2	MK	06	3.3V	REELED TAPE	300
ORG1518-MK06-UAR	MK	06	5V USB	EVALUATION KIT	1

TABLE 18 – ORDERABLE DEVICES

The default constellation is GPS, GLONASS and Galileo, since May 28, 2017. Prior to May 28, 2017 the default constellation was GPS + GLONASS.

GPS + BEIDOU constellations are also available. For ordering this option contact sales@origingps.com

APPENDIX 1 – MULTI MICRO HORNET ORG1518-MK06

The ORG1518-MK06 version has an option to connect a coin battery (for example ECR2025 coin battery) to provide power in backup mode. Minimum voltage that the backup battery will support is 2.8V. With a battery connection, after waking up, the receiver uses:

1. All internal aiding, including RTC time, Ephemeris, and Last Position, resulting in the fastest possible TTFF in either hot or warm start modes.
2. Configuration settings stored in flash after turning power off.

To keep alive the RTC time, the following circuit implementation using a 3V coin battery, can be used. In addition, you need to consider using a charger for the battery or separating the VCC and V_BACKUP with using controlled LDO for each of them.

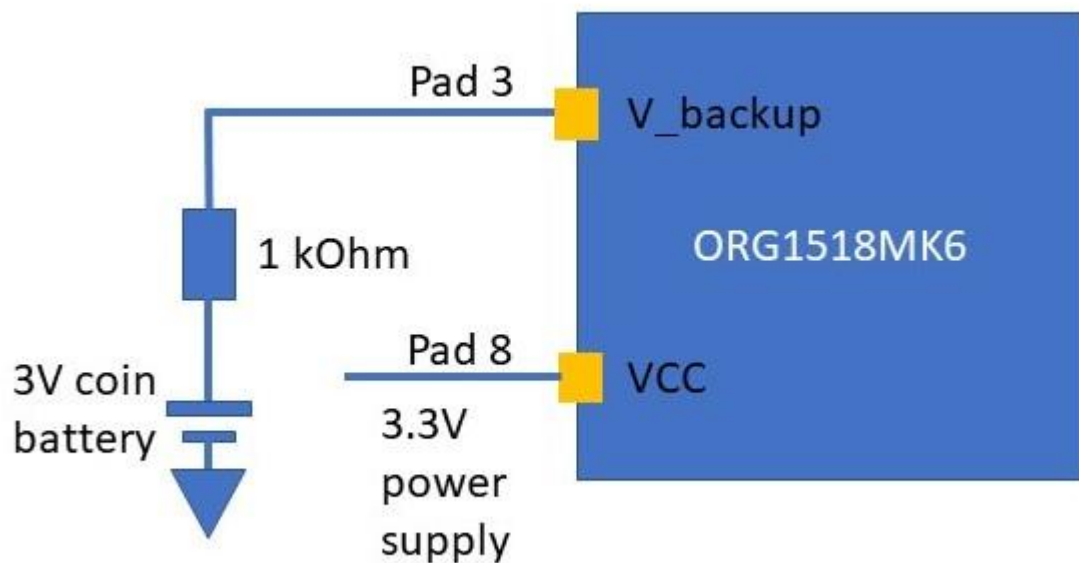

FIGURE 15 – BATTERY BACKUP IMPLEMENTATION

If a battery is not connected to pad 3 in ORG1518-MK06, connection between pads 8 and 3 is a MUST in order to operate the module.