



CLD-1212-INT-EB

12V / 1A Wall mounted type AC/DC adaptor

■ Features:

- Universal AC input / Full range
- Wall mounted type, Isolation class II design
- ErP step II / CEC level VI compliance
- No load power consumption $P < 0.075W$
- Protections: Overload / Short circuit / Over Temperature



ELECTRICAL SPECIFICATION

MODEL	CLD-1212-INT-EB
OUTPUT	
Rated Voltage	12V
Rated Current	1A
Current Range	0 ÷ 1A
Rated Power	12W
Line Regulation	± 2%
Load Regulation	± 5%
Tolerance [3]	± 8%
Ripple & Noise (max.) [2]	120mV _{p-p}
Setup, Rise Time [4]	1000ms, 20ms / 230VAC at full load
Hold up Time (typ.)	10ms / 230VAC at full load

INPUT	
Voltage Range	90 ÷ 264VAC
Frequency Range	47 ÷ 63Hz
Efficiency (typ.)	84.59%
AC Current (typ.)	0.13A / 115VAC, 0.065A / 230VAC
No load Power Consumption (max.)	0.075W

PROTECTIONS	
Overload	Range: 140-180%
	Type: hiccup mode, auto-recovery.
Short Circuit	Type: hiccup mode, auto-recovery.
Over temperature	Type: hiccup mode, auto-recovery



CLD-1212-INT-EB

12V / 1A Wall mounted type AC/DC adaptor

WORKING ENVIRONMENT

Working Temperature	0°C ÷ 40°C
Working Humidity	10 ÷ 90% RH non-condensing
Storage Temperature and Humidity	-20°C ÷ 85°C, 5 ÷ 90% RH non-condensing

SAFETY and EMC REGULATIONS

Safety Standards	Compliance to EN 62368
Withstand Voltage	IN/OUT: 3.6kVAC
Isolation Resistance	IN/OUT: 100MΩ/500VDC/25°C/70%
EMC Emission	Compliance to EN55032
EMC Immunity	Compliance to EN61000-4-2, -3, -4, -5
Harmonic Current	Compliance to EN61000-3-3; EN61000-3-2

MECHANICAL SPECIFICATION

Wire and plug	Wire: 20AWG, length = 106,5cm ±50mm	Plug: AC230V
	Wire: 22AWG, length = 126,5cm ±50mm	Plug: 2.1/5.5, positive inside
Dimensions	90 x 75 x 30mm (L x W x H)	
Net Weight / gross	115g / 136g	

1. All parameters NOT specially mentioned are measured at 230VAC input, rated load and 25°C of ambient temperature.
2. Ripple & noise are measured at 20MHz of bandwidth by using a 12" twisted pair-wire terminated with a 0.1µF i 47µF parallel capacitor.
3. Tolerance includes set up tolerance, line regulation and load regulation.
4. Setup and rise time is measured from 0 to 90% rated output voltage.
5. Power supply is considered as component not indented to apply by end-user. Power supply meets safety and EMC standards however the final equipment with power supply must be re-quality to comply with EMC Directives.

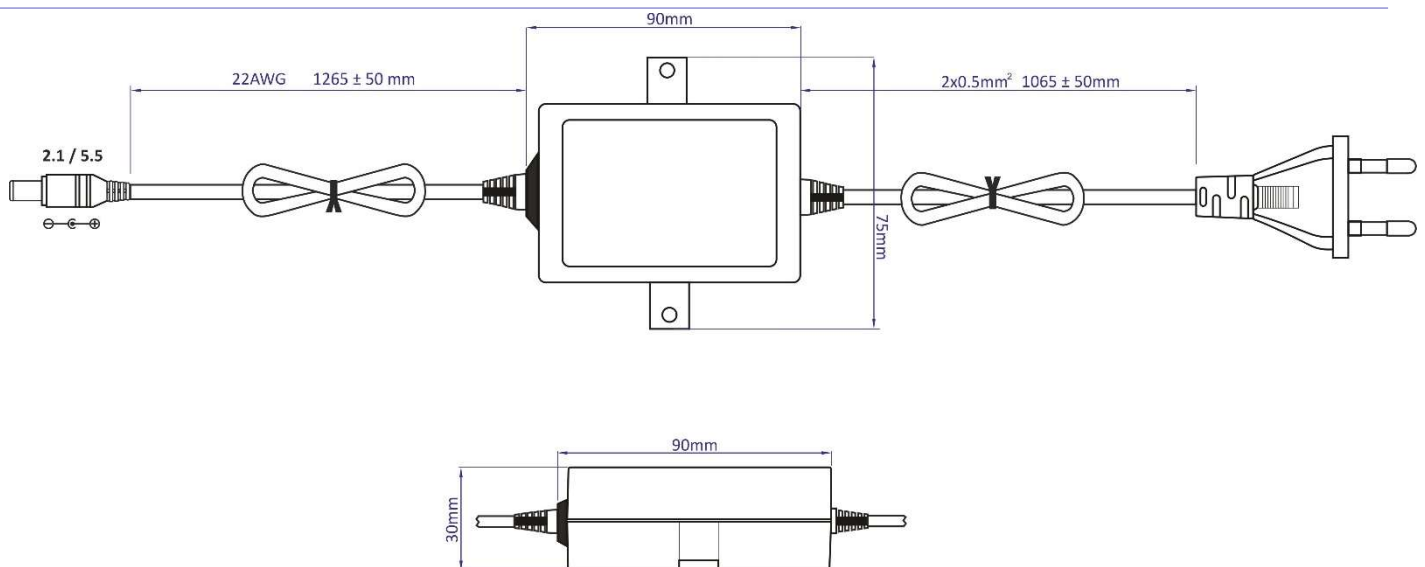

MECHANICAL SPECIFICATION - Wire and plug

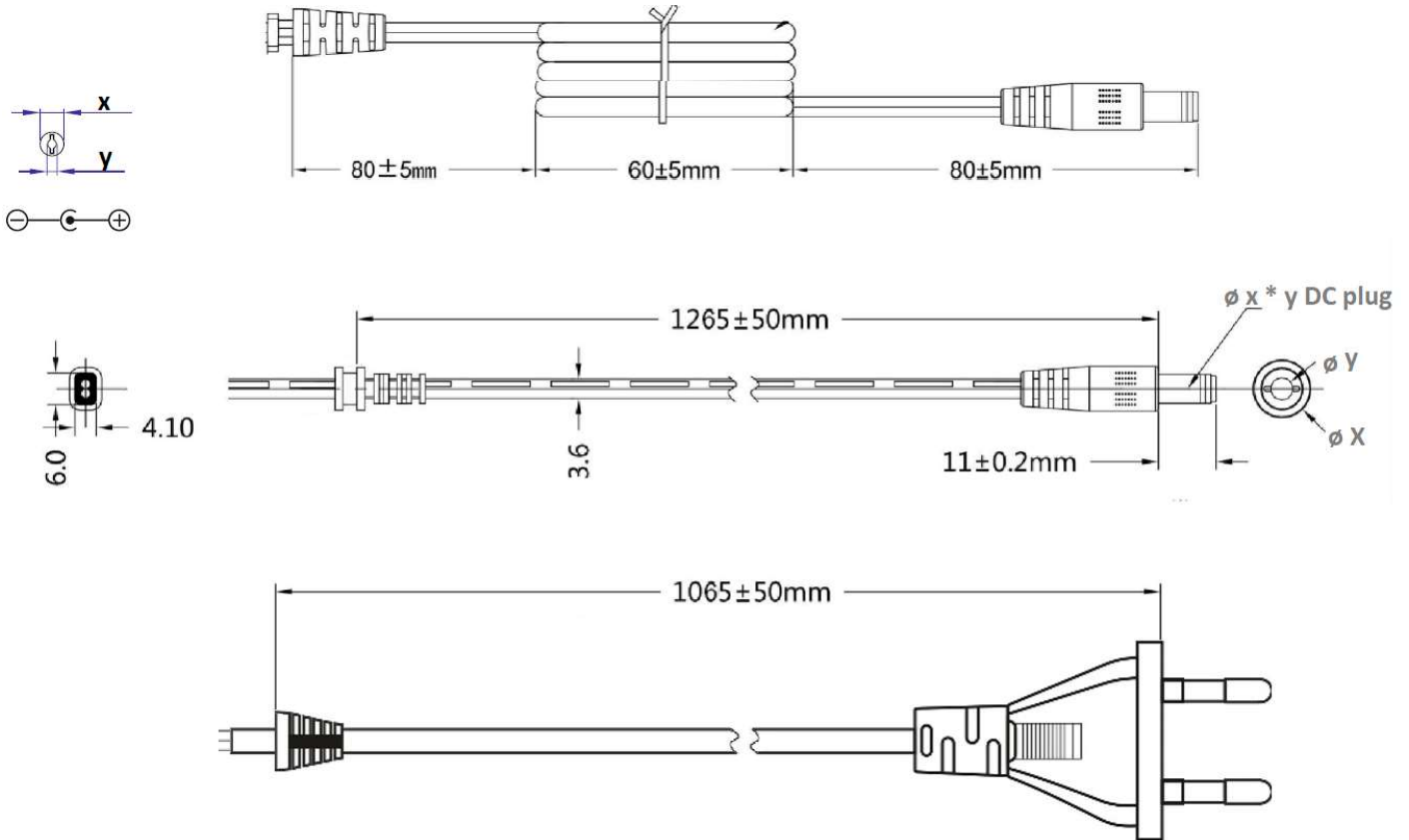

*MODEL	DC PLUG	X [mm]	Y [mm]	Polarity
CLD-1212-INT-EB	5.5x2.1mm	5.5	2.1	center positive
CLD-1212-INT-EB25	5.5x2.5mm	5.5	2.5	center positive
CLD-1212-INT-EB13	3.5x1.3mm	3.5	1.3	center positive
CLD-1212-INT-EB40	4.0x1.7mm	4.0	1.7	center positive
CLD-1212-INT-EB48	4.8x1.7mm	4.8	1.7	center positive
CLD-1212-INT-EB-CN	5.5x2.1mm	5.5	2.1	center negative
CLD-1212-INT-EB25-CN	5.5x2.5mm	5.5	2.5	center negative
CLD-1212-INT-EB13-CN	3.5x1.3mm	3.5	1.3	center negative
CLD-1212-INT-EB40-CN	4.0x1.7mm	4.0	1.7	center negative
CLD-1212-INT-EB48-CN	4.8x1.7mm	4.8	1.7	center negative