

ESPE-HDN9012

- high quality DIN rail 12 V power supply

FEATURES:

- compact design
- high power output
- premium class design
- fully protected, low inrush
- voltage trimmer, power LED
- perforated enclosure
- double terminal block

APPLICATIONS:

- industrial automation
- home and building automation
- monitoring and safety systems
- lighting systems

ESPE-HDN9012 is a high quality, efficient switched-mode power supply in a plastic housing for mounting on a DIN TS35 mm rail with a width of 4U. Its design is based on high-quality electronic components that allow for continuous, long-term operation. It is reliable, fully protected and stable. Provides high efficiency and excellent specification. The perforated enclosure provides good ventilation, and the trimmer allows to accurately adjust the voltage to compensate for the voltage drop across the wires. Double output terminals make it easy to connect load.



TECHNICAL SPECIFICATION

Group	Parameter	Value	Conditions
Input	Rated input voltage	100-240 VAC	
	Input voltage range	90-264 VAC	
	Mains frequency range	47-53 Hz	
	AC current (max.)	2.2 A	At 100 VAC and full load
	Inrush current (max.)	60 A	
	No load power consumption	0.35 W	
	Input leakage current (max.)	Max. 0.25 mA	At 264 VAC
	Power factor correction	No	
	Typical power factor	0,6	
Output	Rated output voltage	12 V	
	Trim range	11-13 V	
	Rated output power	85 W	
	Rated output current	7.1 A	
	Efficiency	89%	At 230 VAC
	Efficiency at 10% load	87%	
	Line regulation	±2%	
	Load regulation	±3%	
	Ripple and noise	150 mVp-p	At 240 VAC
	Minimal output current	No	
	Hold up time (max.)	Over 5 ms	At 230 VAC and full load
	DC voltage rise time (max.)	Up to 40 ms	At 230 VAC and full load
	Turn on delay time (max.)	0.5 s	At 230 VAC and full load
Environmental	Working temperature	0 to +40°C	
	Working humidity	25% to 75% RH	40°C
	Storage temperature	-10°C to +80°C	
	Cooling method	Free air circulation	
Protection	Short circuit	Yes	
	Overcurrent	120-140%	
	Output overvoltage	Yes	
	Automatic recovery on fault remove	Yes	
Safety and EMC	Withstand isolation voltage	3 kVAC (input to output)	5 mA, 1 min
	Isolation resistance	100 MΩ	500 VDC
	Isolation class	2	
	Safety compliance	EN62368	
	EMC compliance	EN55032 class B	
	Marking	RoHS, CE	
Mechanical and features	Enclosure	Grey ABS plastic	
	Dimension	90 × 58 × 70 mm	L × W × H
	Weight	243 g	
	Output connector	Double pins terminal block	
	Input connector	Terminal block	
	Single package	100 × 80 × 72 mm	
	Packing	420 × 220 × 380 mm	50 items
	Manufacturing	China	
Warranty	3 years		

Notes:

Unless otherwise stated, all parameters are specified at 230 VAC input voltage, 50 Hz, ambient temperature 25°C and relative humidity 70% for rated load output. The values of parameters related to the output voltage regulation is measured from low to high line or for load changes from 0 to 100%, respectively. The power supply is considered as an independent unit, but the final equipment still need to reconfirm that the whole system complies with the EMC directives. If the PSU is installed in the final device as a subassembly, the tests should be repeated to verify that the system has been met compliance. Detailed technical data are available on request.

BLOCK DIAGRAM

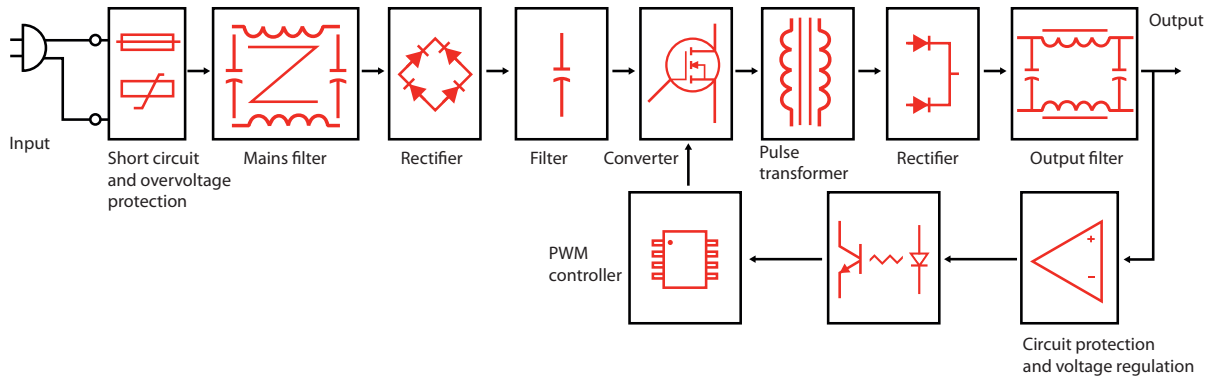

MECHANICAL SPECIFICATION

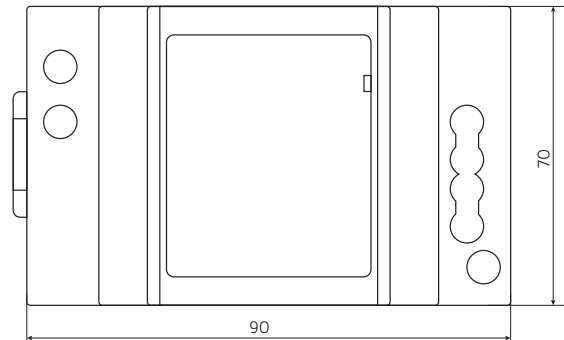
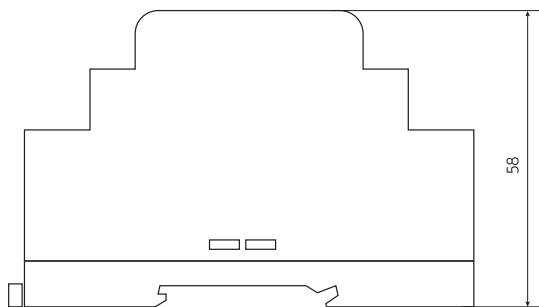

PRODUCT LABEL

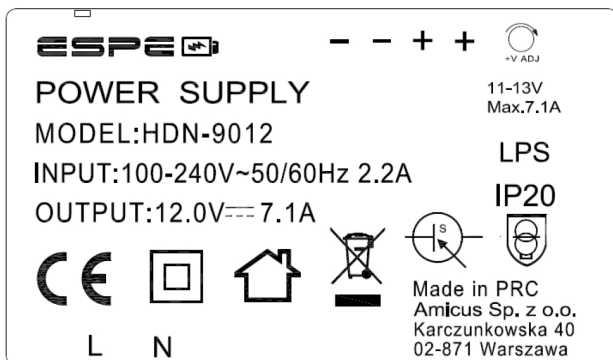

Legend to the label icons:

- L - line connection (brown wire)
- N - neutral connection (blue wire)
- + - output plus (positive) wire (red)
- - output minus (negative) wire (black)
- II safety class: no grounding is required, no dangerous voltage even in an emergency situation will appear on output
- power supply intended for indoor use only
- it can be installed separately outside a lighting fixture without an additional housing
- switched mode power supply
- LPS - a Limited Power Source (LPS) as defined in IEC 62368-1 and IEC 60950, is a secondary circuit with an open circuit output voltage, UOC, not exceeding the SELV circuit limits of 42.4 VPEAK or 60 VDC.
- means safety isolating control gear with short circuit protection
- the product must not be disposed of in normal waste containers
- IP20 - defined in EN 60529 levels of sealing effectiveness of electrical enclosures against intrusion from foreign bodies (tools, dirt) and moisture

OTHER POWER SUPPLIES IN THIS SERIES

Model	ESPE-HDN1005	ESPE-HDN3012	ESPE-HDN5412	ESPE-HDN9012
Rated output voltage	5 V	12 V	12 V	12 V
Rated output current	2 A	2 A	4.5 A	7.1 A
Rated output power	10 W	24 W	54 W	85 W
Enclosure	1U	2U	3U	4U
Dimensions	90 × 58 × 18 mm	90 × 58 × 35 mm	90 × 58 × 52 mm	90 × 58 × 70 mm

MARKING SYSTEM

ESPE-HDN9012

- Rated output voltage **12 V**
- Output power **90 W**
- Series **HDN**
- Family **ESPE**