

# KPS<sup>®</sup>

## TP5000HY

User Manual / MANUAL DEL USUARIO /  
Manuel d'utilisation / Benutzerhandbuch /  
Manuale Utente



UK  
CA













**3**  
YEARS  
LIMITED  
WARRANTY

- EN True RMS Electrical Tester
- ES Probador eléctrico de RMS real
- FR Testeur électrique TRMS
- DE Echter RMS Elektrischer Tester
- IT Tester Elettrico Vero RMS

## **WARNING**

- If the equipment is used in a manner not specified by the manufacturer, the protection provided by the equipment may be impaired.
- Always use proper terminals, switch position, and range for measurements.
- To reduce the risk of fire or electric shock, do not use this product around explosive gas or in damp locations.
- Verify the Meter operation by measuring a known voltage.  
If in doubt, have the Meter serviced.
- Do not apply more than the rated voltage, as marked on Meter, between terminals or between any terminal and earth ground.
- Avoid working alone so assistance can be rendered.
- Do not use the Tester if the Tester is not operating properly or if it is wet.
- Individual protective device must be used if hazardous live parts in the installation where the measurement is to be carried out could be accessible.
- Use caution with voltages above 30 Vac rms, 42 Vac peak, or 60 Vdc. These voltages pose a shock hazard.
- DO NOT USE the test leads when the internal white insulation layer is exposed
- DO NOT USE the test leads above maximum ratings of CAT. environment, voltage and current, that are indicated on the probe and the probe tip guard cap.
- DO NOT USE the test leads without the probe tip guard cap in CAT III and CAT IV environments.
- Probe assemblies to be used for MAINS measurements shall be RATED as appropriate for MEASUREMENT CATEGORY III or IV according to IEC 61010 -031 and shall have a voltage RATING of at least the voltage of the circuit to be measured.
- Disconnect circuit power and discharge all high-voltage capacitors before testing resistance, continuity.

## **Symbols as marked on the Meter and Instruction manual**

	Risk of electric shock		See instruction manual
	DC measurement		AC measurement
	Both direct and alternating current		Equipment protected by double or reinforced insulation
	Battery		Earth
	Conforms to EU directives		Application around and removal from hazardous live conductors is permitted
	Do not discard this product or throw away.		

## **Maintenance**

Do not attempt to repair this Meter. It contains no user serviceable parts. Repair or servicing should only be performed by qualified personnel.

## **CAUTION**

- When connecting the test leads to the DUT (Device Under Test) connect the common test leads before connecting the live test leads ; when removing the test leads, remove the live test leads before removing the common test leads.
- Make sure that the buzzer sound is perceptible before using it under high background noise environment.

## Voltage / Continuity / Single Pole Mode

### Voltage Measurement

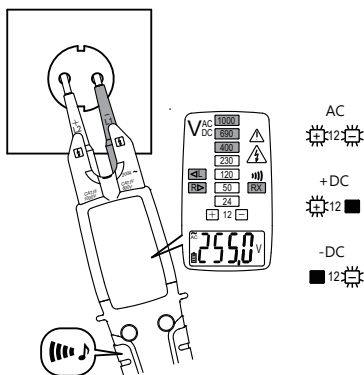

LED indicates measured voltage is high than ELV limit (50VAC and/or 120VDC).

### Warning

- When batteries are not fitted or are exhausted, the tester still work when measuring > 45VAC and/or > 35VDC.
- Timing Rating (tr): 30 seconds, Recovery Time (rt): 240seconds, when measuring > 300V, recovery time is necessary.
- L/R LED may light up when measuring AC voltage.
- Due to the high internal resistance, capacitive and inductive Voltage (ghost voltage) may be indicated.

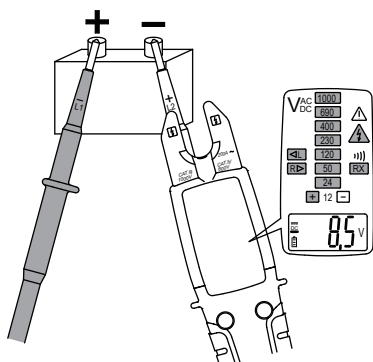

### Phase Rotation Test

- Clockwise Phase Sequence L1-L2-L3(Right)

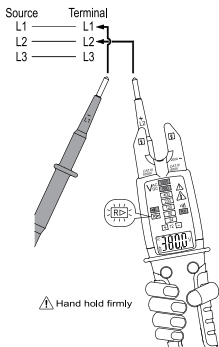

- Counterclockwise Phase Sequence L1-L3-L2(Left)

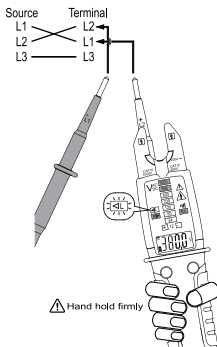

Phase Rotation Test works only on 3 phase 4 wire system. The result is unreliable on other systems.

It is necessary to check the result by test with reverse sequence.

### Single Pole Phase Check

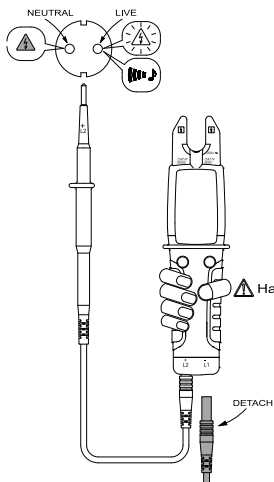

#### ⚠ Warning

- Single Pole Check is available for both test leads. Remove one of test leads before performing check.
- Do not check if voltage appears by Single Pole Phase Check. Measure voltage with two pole to get a reliable result.

### Continuity Check

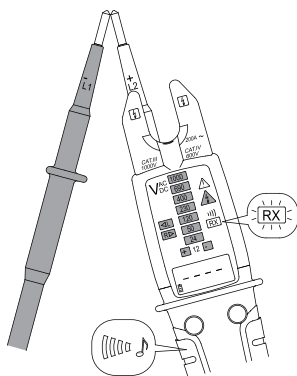

### Resistor Mode

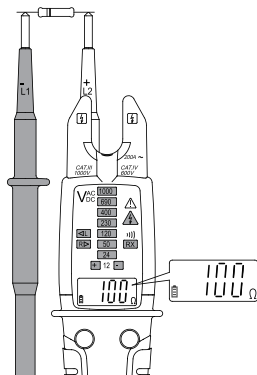

### Ampere Mode

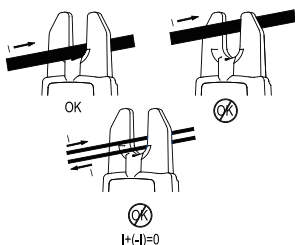
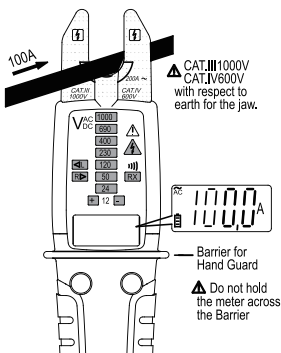

#### ⚠ Warning

- The barrier on the body is indicating the limit of safe access of the hand-held part, do not hold over the barrier when in normal use.
- Do not assemble test lead at the back of the meter while measuring current.

## Using the Function

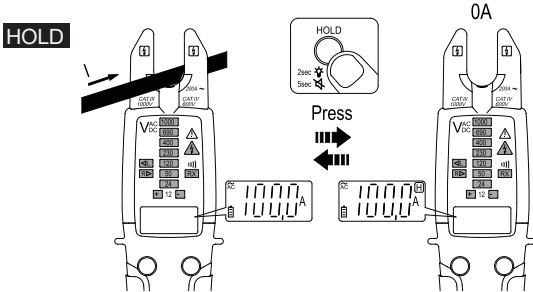

## Enable/Disable ELV Warning Voice

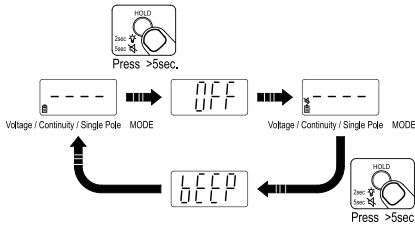

## Turn the meter OFF

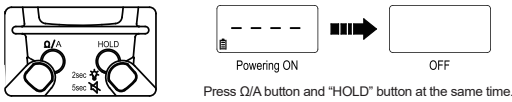

## Torch

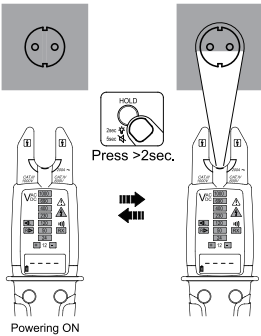

## Self-Diagnostic Test

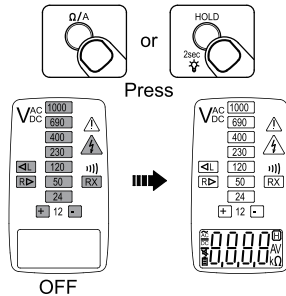

## Warning

Do not use the tester when abnormality is found in self-diagnostic test.

## Function Button

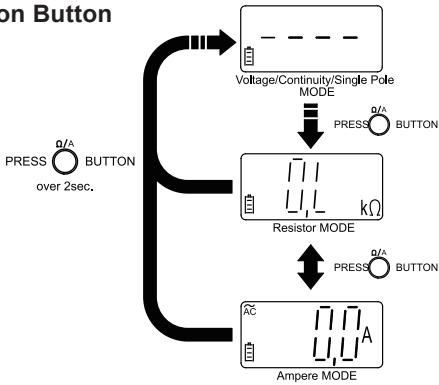

## Battery Replacement

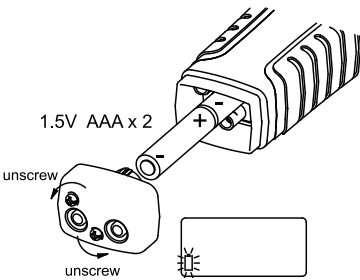

### Warning

- To avoid false readings that can lead to electric shock and injury, replace the battery as soon as low battery indicator
- Remove test lead from Meter before opening the battery door or Meter case.

## Probe Usage

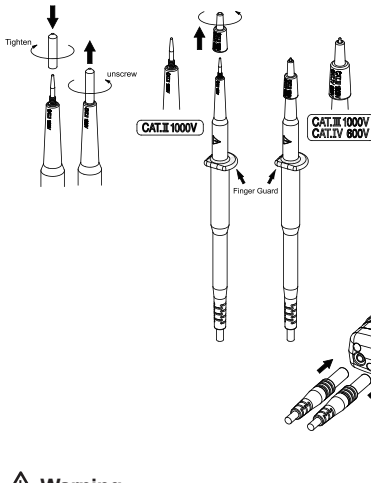

### Warning

When using test leads or probes, keep your fingers behind the finger guards.

### Warning

- For CAT III or CAT IV environments, use the test leads with the probe tip guard fixed firmly. Without the probe tip guard cap, the test leads can be used in CAT II environment ONLY.
- Make sure test leads are firmly connected to instrument and other accessories.

**Test lead assembly****⚠ Warning**

Do not assemble test lead at the back of the meter while measuring current.

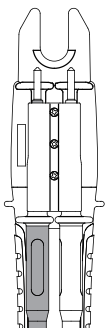

Storage

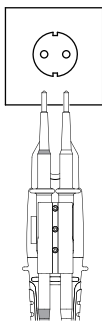

For 19mm power socket

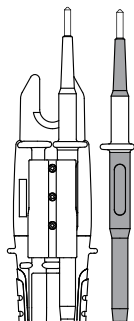

For most application except ampere measurement.

**Specifications****1-1 General Specifications**

**Display Count :** 10000 counts.

**Overrange Display :** "OL" or "-OL"

**Conversion Rate :** 3 times/second

**Dimensions (W x H x D) :** 57 x 220 x 35 mm

**Weight :** 200g

**Power Requirements :**

AAA Size Battery x2 (R03, LR03, 24D, 24A)

**Battery Life :** About 1000 operations. (based on Alkaline batteries, 30 sec. ON, 240 sec. OFF)

**Maximum Conductor Size :** 16mm

**Safety Standard Compliance :**

IEC / EN 61010-1, IEC / EN 61010-2-032, IEC / EN 61010-2-033,

IEC / EN 61010-031 for CAT IV 600V, CAT III 1000V

IEC / EN 61326-1, IEC / EN 61243-3

**CAT****Application field**

II	The circuits directly connected to Low-voltage installation.
III	The building installation.
IV	The source of the Low-voltage installation.

**1-2 Environmental Conditions**

Indoor / Outdoor Use

**Pollution Degree :** 2

**Maximum Operating Altitude :** 2000m (6562ft)

**Operating Temperature & Relative Humidity :**

-15°C ~ 30°C, ≤80%RH

30°C ~ 40°C, ≤75%RH

40°C ~ 55°C, ≤45%RH

**Storage Temperature :** -20 to +60°C, 0 to 80% RH (no batteries)

**Temperature Coefficient :**

0.2 x (Specified accuracy) / °C, < 18°C, > 28°C

**IP Rating :** IP65

**Vibration :** Random Vibration per MIL-PRF-28800F Class 2

**Drop Protection :** 4 feet drop to hardwood on concrete floor

### 1-3 Electrical Specifications

Accuracy is given as  $\pm$  (% of reading + counts of least significant digit) at 23°C  $\pm$  5°C, with relative humidity Less than 80% R.H., and is specified for 1 year after calibration.

#### • Condition of Auto Power On :

##### With batteries fitted :

- > 3.0V or < -8.0V between L2 and L1
- Detect AC signal by Single Pole
- Continuity

##### Without batteries :

- > |  $\pm$ 35.0V DC | or > 45.0V AC between L2 and L1

#### • Auto Power Off :

The Meter automatically turns off if one of the following conditions are met for about 10 seconds

- The Auto Power On condition is not met.
- Both buttons are not pressed.

The Meter automatically turns off if one of the following conditions are met for about 30 seconds

- The resistance is OL when the Meter is in Resistor mode.
- The current is < 1.0A when the Meter is in Ampere mode

- For > 300V, Time rating (tr): 30 seconds; Recovery time (rt): 240 seconds

#### • AC Function

- ACV and ACA specifications are ac coupled, true RMS.
- For non-sinusoidal waveforms, Additional Accuracy by Crest Factor (C.F.) :

Add 1.0% for C.F. 1.0 ~ 2.0

Add 2.5% for C.F. 2.0 ~ 2.5

Add 4.0% for C.F. 2.5 ~ 3.0

- Max. Crest Factor of Input Signal:

3.0 @ 5000 counts

1.5 @ 10000 counts

#### • DC Voltage

	Range	Resolution	Accuracy
With batteries	7.0V to 999.9V	0.1V	$\pm(1.0\% + 2D)$
Without batteries <sup>(1)</sup>	35V to 999.9V	0.1V	

(1) Measurement without batteries is only available for < 35°C, > -15°C. The meter will show "bAtt" and ELV LED when measurement is not available.

**Max. Input Current** : < 3.5mA @ 1000V

**Overload Protection** : AC/DC 1000V

#### • AC Voltage

	Range	Resolution	Accuracy
With batteries	6.0V(1) to 999.9V	0.1V	$\pm(1.5\% + 5D)$
Without batteries <sup>(2)</sup>	45V to 999.9V	0.1V	

(1) For > 65Hz, the minimum range is 8.0V.

(2) Measurement without batteries is only available for < 35°C, > -15°C. The meter will show "bAtt" and ELV LED when measurement is not available

**Frequency Response** : 45Hz to 400Hz

**Max. Input Current** : < 3.5mA @ 1000V

**Overload Protection** : AC/DC 1000V



---

**• Resistor**

Range	Resolution	Accuracy
9999Ω	1Ω	±(1.5% + 5D)
50.00kΩ	0.01kΩ	

**Output Voltage** : about 0.5V

**Overload Protection** : AC/DC 1000V

**• Continuity**

**Continuity** : The built-in buzzer sounds in the case of measuring resistance less than 1.8kΩ and may be up to 2.7kΩ. LED RX shows at the same time.

**Continuity Indicator** : 2.7kHz Tone Buzzer and RX LED

**Response Time of Buzzer** : < 100 msec.

**Output Voltage** : about 0.5V

**Overload Protection** : AC/DC 1000V

---

**• AC Ampere**

Range	Resolution	Accuracy
200.0A	0.1A	±(3.0% + 5D)

**Frequency Response** : 45Hz to 65Hz

**Overload Protection** : AC/DC 200A

**• Rotary Field Indication**

For 3 phase 4 wire system only

**Sensitivity** : 90V to 1000V (Phase-to-ground)

**Frequency Range** : 45Hz to 65Hz

"L" LED is on when the signal of L2 probe lead the signal of L1 probe; "R" LED is on when the signal of L1 probe lead the signal L2 probe.

**• Single-Pole Phase Check**

**Sensitivity** : 90V to 1000V (Phase-to-ground)

**Frequency Range** : 45Hz to 65Hz

**Indicator** : 2.7kHz Tone Buzzer and ELV LED

---

## SAFETY ADVICES

Depending on the internal impedance of this meter there will be a different capability of indicating the presence or absence of operating voltage in case of the presence of interference voltage.

When in contact with the parts to be tested, this meter may discharge temporarily the interference voltage to a level below the ELV, but it will be back to the original value when this meter is removed.

When the indication "voltage present" does not appear, it is highly recommended installing earthing equipment before work.

When the indication "voltage present" appears on a part that is expected to be disconnected of the installation, it is highly recommended confirming by another means (e.g. use of an adequate voltage detector, visual check of the disconnecting point of the electric circuit, etc.) that there is no operating voltage on the part to be tested and to conclude that the voltage indicated by this meter is an interference voltage.