

# KPS<sup>®</sup>

## DCM8500PV

User Manual / MANUAL DEL USUARIO /  
Manuel d'utilisation / Benutzerhandbuch /  
Manuale Utente



UK  
CA

CE



**3**  
YEARS  
LIMITED  
WARRANTY

- EN All New Designed Bluetooth Clamp Meter
- ES Pinza amperimétrica bluetooth con nuevo diseño
- FR Toute nouvelle pince ampèremétrique Bluetooth
- DE Ganz neu entwickeltes Bluetooth-Zangenmessgerät
- IT Una Pinza Amperometrica Bluetooth di progettazione assolutamente nuova













## Safety Information

Understand and follow operating instructions carefully. Use the meter only as.

### WARNING

- If the equipment is used in a manner not specified by the manufacturer, the protection provided by the equipment may be impaired.
- Always use proper terminals, switch position, and range for measurements.
- To reduce the risk of fire or electric shock, do not use this product around explosive gas or in damp locations.
- Verify the Meter operation by measuring a known voltage. If in doubt, have the Meter serviced.
- Do not apply more than the rated voltage, as marked on Meter, between terminals or between any terminal and earth ground.
- To avoid false readings that can lead to electric shock and injury, replace the battery as soon as low battery indicator blinks.
- Avoid working alone so assistance can be rendered.
- Do not use the Tester if the Tester is not operating properly or if it is wet.
- Individual protective device must be used if hazardous live parts in the installation where the measurement is to be carried out could be accessible.
- Disconnect the test leads from the test points before changing the position of the function rotary switch.
- Never connect a source of voltage when the function rotary switch is not in voltage position.
- When using test leads or probes, keep your fingers behind the finger guards.
- Use caution with voltages above 30 Vac rms, 42 Vac peak, or 60 Vdc. These voltages pose a shock hazard.
- Remove test lead from Meter before opening the battery door or Meter case.
- DO NOT USE the test leads when the internal white insulation layer is exposed.
- DO NOT USE the test leads above maximum ratings of CAT.  
environment, voltage and current, that are indicated on the probe and the probe tip guard cap.
- DO NOT USE the test leads without the probe tip guard cap in CAT III and CAT IV environments.
- Probe assemblies to be used for MAINS measurements shall be RATED as appropriate for MEASUREMENT CATEGORY III or IV according to IEC 61010-031 and shall have a voltage RATING of at least the voltage of the circuit to be measured.
- Disconnect circuit power and discharge all high-voltage capacitors before testing resistance, continuity, diodes, or capacitance.
- De-energize the installation under test or wear suitable protective clothing during fitting and removal of the Flexible Current Probe.
- Do not apply around or remove from UNINSULATED HAZARDOUS LIVE conductors, which may render electric shock, electric burn, or arc flash.

## Symbols as marked on the Meter and Instruction manual

	Risk of electric shock		See instruction manual
	DC measurement		AC measurement
	Wireless transmission		Both direct and alternating current
	Equipment protected by double or reinforced insulation		Low battery
			Earth ground
	Application around and removal from hazardous live conductors is permitted		Conforms to EU directives
			Do not discard this product or throw away.

## Unsafe Voltage

To alert you to the presence of a potentially hazardous voltage, when the Tester detects a voltage  $\geq 30$  V or a voltage overload (OL) in V, mV, LoZ. The ⚡ symbol is displayed.

## Maintenance

Do not attempt to repair this Meter. It contains no user serviceable parts. Repair or servicing should only be performed by qualified personnel.

## Cleaning

Periodically wipe the case with a dry cloth and detergent.  
Do not use abrasives or solvents.

## Introduction

### The Meter Description

Front Panel Illustration

1. JAW
2. Volt seek Light.
3. Push-buttons.
4. Trigger.
5. Rotary switch for turn the Power On / Off and select the function.
6. 6,000 count digital display.
7. Input Terminal for Multi-function.
8. Common (Ground reference) Input Terminal.

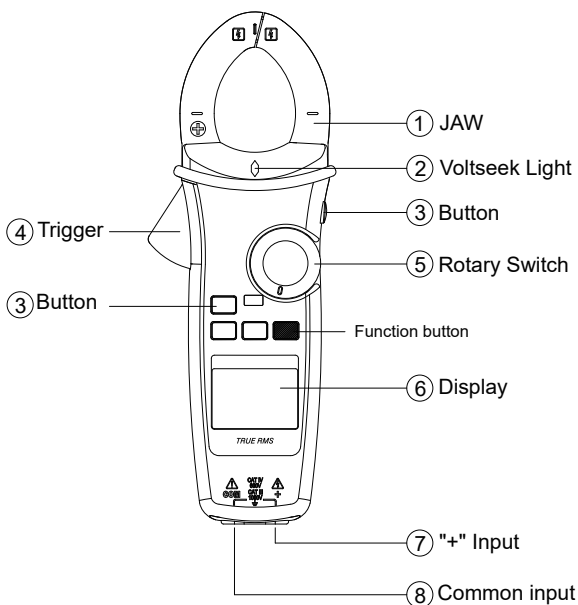

## Making Basic Measurements

### ⚠ CAUTION

When connecting the test leads to the DUT (Device Under Test) connect the common test leads before connecting the live test leads ; when removing the test leads, remove the live test leads before removing the common test leads.

### Measuring Voltage

Dial the switch to select the measuring function.

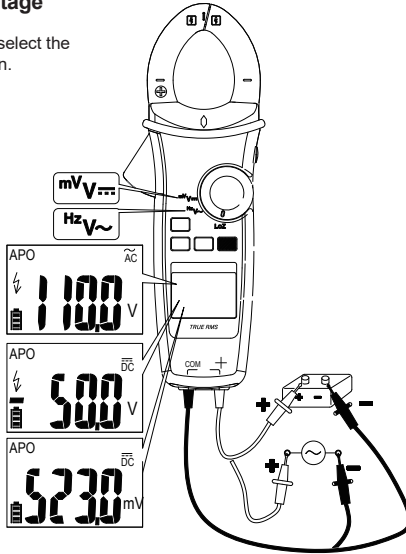

### Measuring PV Voltage

Dial the switch and press the Function button to select AC/DC mode.

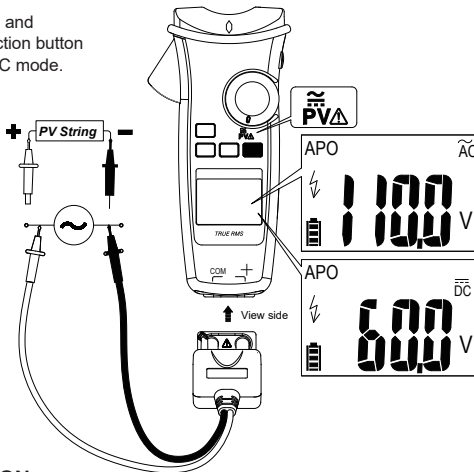

### ⚠ CAUTION

This function is only available with the dedicated PV test probe.

Always select correct DC / AC mode to perform high voltage measurement. This meter will flash ⚡ symbol and the correct mode symbol (AC / DC) if the input voltage is different and dangerous.

## Measuring Current

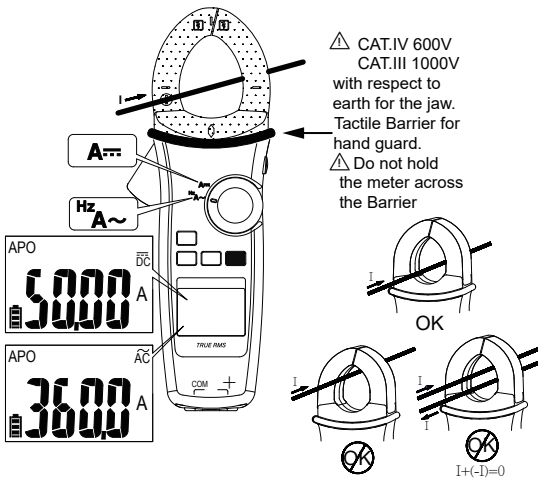

Dial the switch and press the Function button to select the measuring function.  
**Note :** Torch will be on when jaw is opened.

## Measuring Resistance/Continuity/Capacitance/Diode

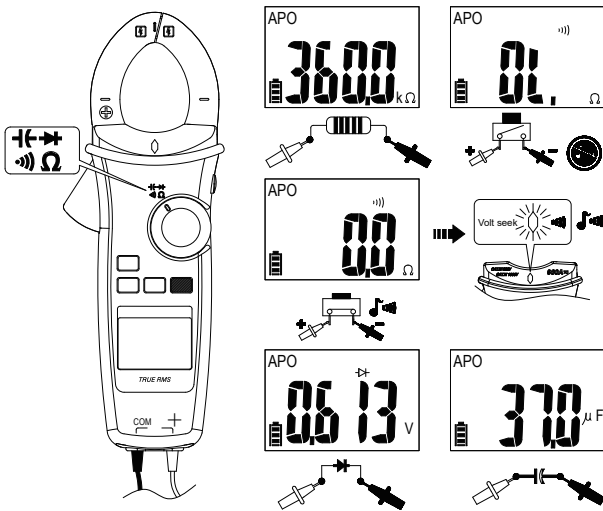

Dial the switch and press the Function button to select the measuring function.

## Measuring Temperature °C / °F

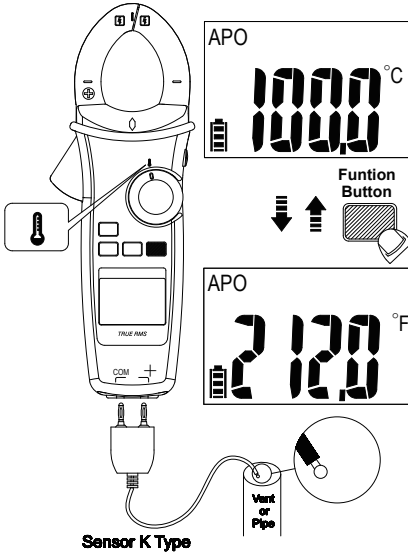

Dial the switch and press the Function button to select °C / °F mode.

## Measuring $\mu\text{A}$

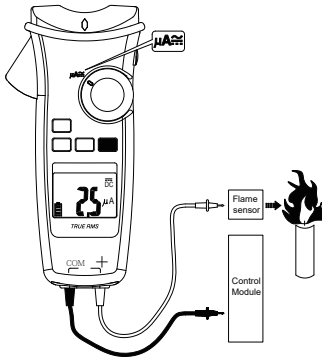

Dial the switch and press the Function button to select AC/DC mode.

## Measuring Current with Flex Clamp Meter

Keep the range of Flex Clamp meter at 3000A/3V output ratio.

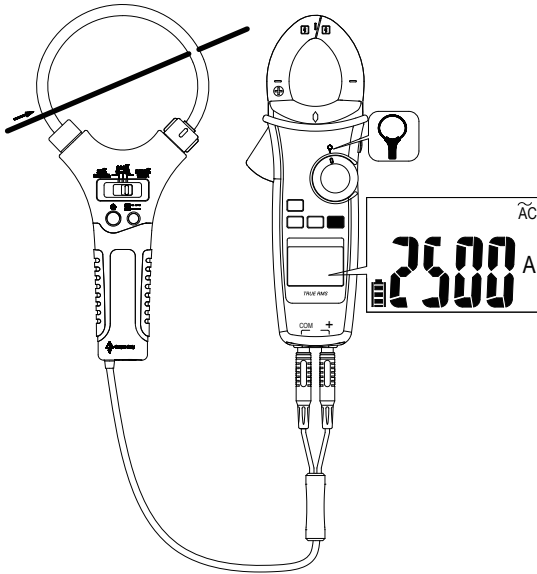

## Using the Function

Switch Position	Function
PV	$\overline{\text{DC}} \rightarrow \tilde{\text{AC}}$
V $\sim$	V $\sim \rightarrow$ Hz
V $\overline{\text{}}$	V $\overline{\text{}} \rightarrow$ mV $\overline{\text{}}$
A $\approx$	A $\overline{\text{}} \rightarrow$ A $\sim \rightarrow$ Hz
$\mu\text{A}$	$\overline{\text{DC}} \rightarrow \tilde{\text{AC}}$
$\Omega$	$\Omega \rightarrow$ $\rightarrow$ $\rightarrow$ $\rightarrow$
$\text{C}$	C $\rightarrow$ $^{\circ}\text{F}$

Press the Function button to change the function on the same switch position.

## Measuring Frequency

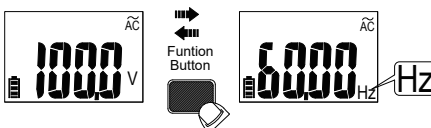

## Backlight

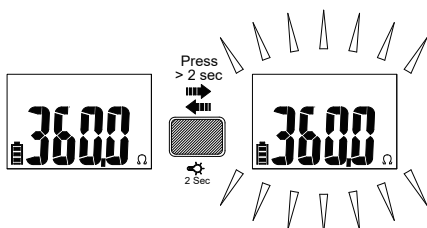

Press Function button for over 2 sec. to turn Backlight on / off.

## MIN/MAX

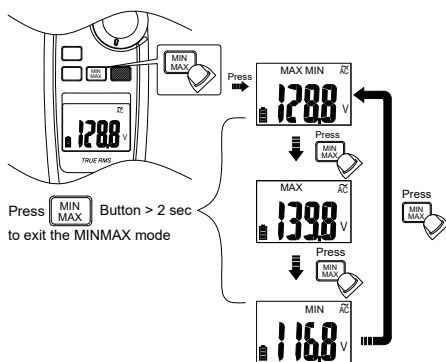

The MAX/MIN mode records the min and max input values. When the input goes below the recorded min value or above the recorded max value, the meter records the new value. Press Hold button to pause the recording.

## Volt Seek

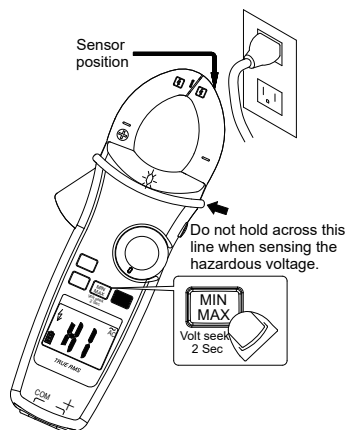

Press MIN/MAX button for over 2 sec. to enter / exit Volt Seek mode.  
Press MIN/MAX button to switch high/low sensitivity.

### ⚠ Warning

The Volt Seek LED indicates the electric field. If the Volt Seek LED is not on, voltage could still be present.



## Smart Hold

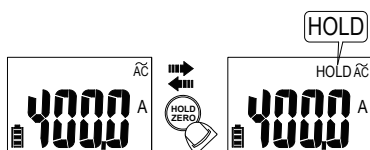

The meter will beep continuously and the display will flash if the measured signal is larger than the display reading by 50 counts.

(However, it can not detect across the AC and DC Voltage / Current).

## DCA ZERO

Remove the jaw from the conductor before performing DCA ZERO.

Press HOLD button for over 2sec. to compensate the residual magnetism.

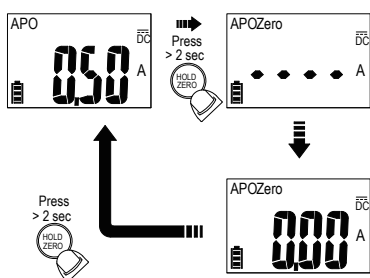

## High Frequency Rejection (HFR)

The High Frequency Rejection mode equip a low pass filter in the AC measurements. The cut-off frequency (-3dB point) of low pass filter is 800Hz.

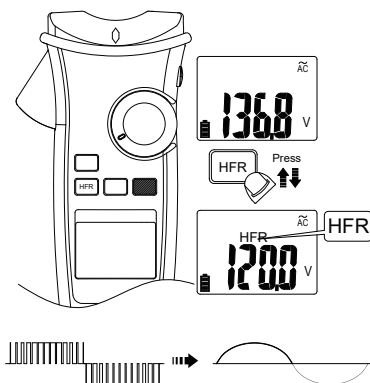

### Warning

The hazardous voltage may be present even if the LCD reading is very low in HFR mode. Verify the voltage again without HFR mode

## INRUSH

In inrush current mode, select the suitable measurement range by pressing HFR/INRUSH button before triggering the inrush current measurement.

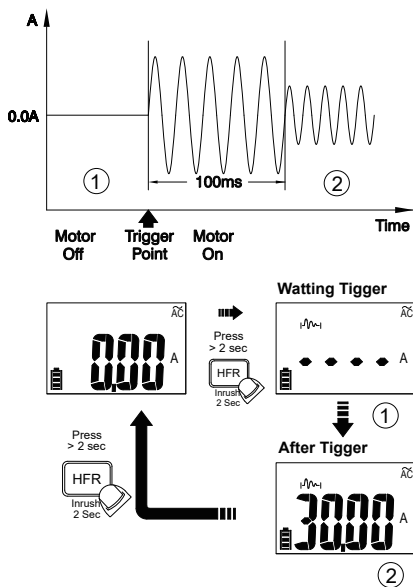

## Auto Power Off

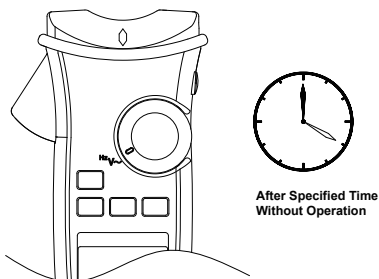

Wake up the meter by dialing the switch or pressing any button.

### Time Setting of Auto Power Off

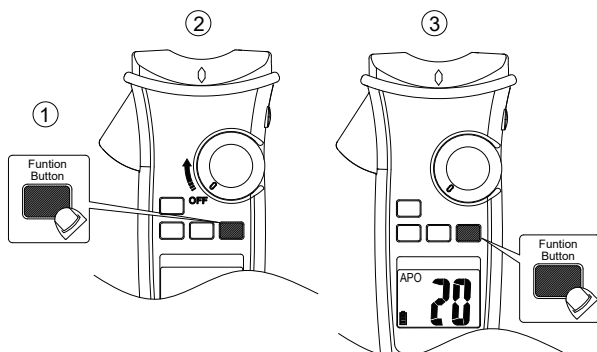

Press the function button and turn the meter on. Then press the function button to select the time. The time can be 5 minutes, 10 minutes, 20 minutes, and disabled (OFF).

### Testing LCD Monitor

To turn on the meter after keeping HOLD button down.

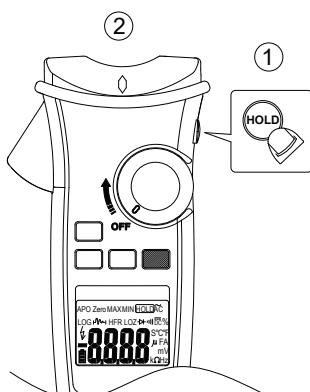

### Function of LOG Button

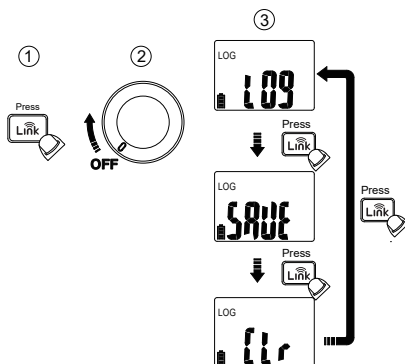

Pressing **Link** button while powering-up to select the mode – Data Logger mode, Manual Saving mode and Clear memory.

## Data Logger

The meter can store up to 4000 data in memory.

Press **Link** button for more than 2 seconds to activate Data logger mode. The meter will enter Time interval setting mode.

Press **Link** button again to select time interval. The interval can be 1 second, 5 seconds, 10 seconds, 30 seconds, 60 seconds.

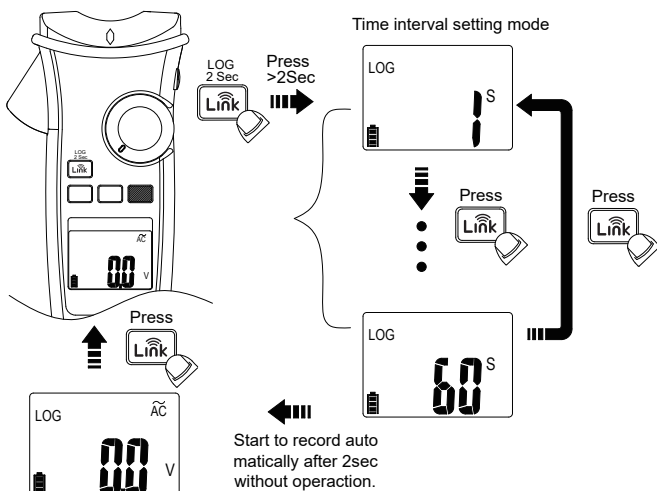

LOG icon flashes while logging

### CAUTION

All stored data will be cleared next startup. Download the stored data by App first if needed.

## Manual Saving Mode

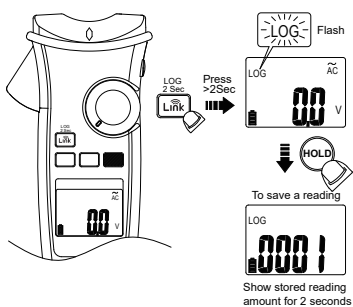

### CAUTION

All stored data are saved until switching to data logger mode or executing the clear function.

## Link

The meter uses Wireless low energy (BLE) V4.0 wireless technology to transfer the real-time reading and the stored data.

The open-air communication range is up to 10m.

Download "KPS Link" App via the following QR Code. Turn on Bluetooth function of the meter and open "KPS Link" to connect the DMM. The Bluetooth icon of the meter will freeze on LCD after the connection establishes successfully.

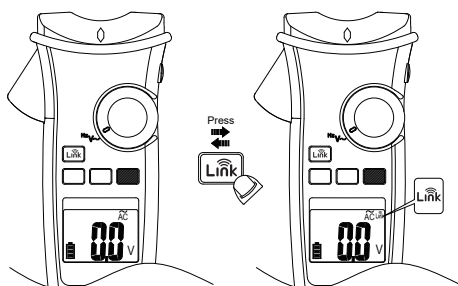

## Default Temperature Units Setting

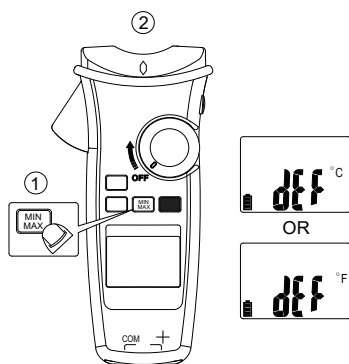

Turn on the meter after keeping MIN/MAX button down.

## Low Battery and Battery Replacement

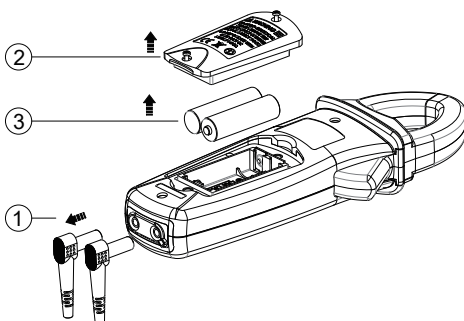

**Warning**

Remove test leads from Meter before opening the battery cover or Meter case.

## Specifications

### General Specifications

**Display** : 6000 counts.

**Overrange Indication** : "OL" or "-OL"

**Measure** : Samples 3 times per second .

**Max Conductor Size of JAW** : 37mm diameter

**Dimensions (W x H x D)** : 62mm x 240mm x 41mm

**Weight** : approx. 430g (including battery)

**Low Batteries Indication** : Voltage drops below operating voltage  will flash.

**Power Requirement** : AA Size Battery x 2 (R6, LR6, 15D, 15A)

**Battery Life** : 200 hours ALKALINE Battery (without Backlight)

**Operating Temperature** : -10 ~10°C

10°C ~ 30°C (≦80% RH),

30°C ~ 40°C (≦75% RH),

40°C ~ 50°C (≦45%RH)

**Storage Temperature** : -20°C to 60°C , 0 to 80% R.H. (batteries not fitted)

**Altitude** : 6561.7 ft (2000m)

### CAT

### Application field

II	The circuits directly connected to Low-voltage installation.
III	The building installation.
IV	The source of the Low-voltage installation.

**Safety** : EN 61010-1, EN 61010-2-032, EN 61010-2-033 for CAT III 1000V, CAT IV 600V, EN 61326-1

**Drop Protection** : 4 feet drop to hardwood on concrete floor

**Vibration** : Random Vibration per MIL-PRF-28800F Class 2

**Pollution degree** : 2

**Indoor Use**

## Electrical Specifications

Accuracy is given as  $\pm$  (% of reading + counts of least significant digit) at  $23^{\circ}\text{C} \pm 5^{\circ}\text{C}$ , with relative humidity Less than 80% R.H., and is specified for 1 year after calibration.

### (1) Temperature coefficient

$0.2 \times$  (Specified accuracy) /  $^{\circ}\text{C}$ ,  $< 18^{\circ}\text{C}$ ,  $> 28^{\circ}\text{C}$

### (2) AC Function

ACV and ACA specifications are ac coupled, true R.M.S.

The crest factor may be up to 3.0 as 4000 counts.

Accuracy is unspecified of Square Wave.

**For non-sinusoidal waveforms, Additional Accuracy by**

**Crest Factor (C.F.) :**

Add 3.0% for C.F. 1.0 ~ 2.0.

Add 5.0% for C.F. 2.0 ~ 2.5.

Add 7.0% for C.F. 2.5 ~ 3.0.

**Max. Crest Factor of Input Signal:**

3.0 @ 3000 counts

2.0 @ 4500 counts

1.5 @ 6000 counts

Frequency Response is specified for sine waveform.

LCD displays 0 counts when the reading  $< 20$  counts.

### (3) DC mV

Range	OL Reading	Resolution	Accuracy
600.0mV	660.0mV	0.1mV	$\pm(0.7\% + 5D)$

SIinput Impedance : 10M $\Omega$

Overload Protection : AC/DC 1000V

### (4) DC Voltage

Range	OL Reading	Resolution	Accuracy
600.0V	660.0V	0.1V	$\pm(0.7\% + 2D)$
1000V	1100V	1V	

SIinput Impedance : 10M $\Omega$

Overload Protection : AC/DC 1000V

### (5) AC Voltage

Range	OL Reading	Resolution	Accuracy
600.0V	660.0V	0.1V	$\pm(1.0\% + 5D)$
1000V	1100V	1V	

Input Impedance : 10M $\Omega$  // less than 100pF

Frequency Response : 45 ~ 400Hz (Sine Wave)

Overload Protection : AC/DC 1000V

### (6) PV DC Voltage

Range	OL Reading	Resolution	Accuracy
600.0V	660.0V	0.1V	$\pm(2.0\% + 5D)$
2000V	2200V	1V	

Input Impedance : 10M $\Omega$

Overload Protection : AC/DC 1000V

## (7) PV AC Voltage

Range	OL Reading	Resolution	Accuracy
600.0V	660.0V	0.1V	±(2.0% + 5D)
1500V	1600V	1V	

**Frequency Response** : 45 ~ 400Hz (Sine Wave)

**Input Impedance** : 10MΩ // less than 100pF

**Overload Protection** : AC/DC 1000V

## (8) AC/DC μA

Range	OL Reading	Resolution	Accuracy
400.0μA	440.0μA	0.1μA	±(1.0% + 3D)
4000μA	4400μA	1μA	

**Input Impedance** : Approx. 2.2kΩ

**Frequency Response** : 45 ~ 400Hz (Sine Wave)

**Overload Protection** : AC/DC 1000V

## (9) DC Current

Range	OL Reading	Resolution	Accuracy
60.00A	66.00A	0.01A	±(2.0% + 5D)
600.0A	660.0A	0.1A	

The measured value <5.0A, add 10 dgt to the accuracy.

The measured value >1000A, add 0.5% to the accuracy.

**Overload Protection** : AC/DC 600A

## (10) AC Current

Range	OL Reading	Resolution	Accuracy
60.00A	66.00A	0.01A	±(2.0% + 5D)
600.0A	660.0A	0.1A	

Add 10 dgt to the accuracy when <5.0A.

Add 0.5% to the accuracy when >1000A.

Add 1% to the accuracy when >100Hz.

**Frequency Response** : (Sine Wave) 45 ~ 400Hz

**Overload Protection** : AC/DC 600A

## (11) Flexible Current Probe

Range	OL Reading	Resolution	Accuracy
300.0A	330.0A	0.1A	±(1.5% + 5D)
3000A	3300A	1A	

**Frequency Response** : 45Hz to 400Hz

Accuracy does not include accuracy of the Flexible Current Probe.

**Overload Protection** : AC/DC 1000V



**(12) Frequency**

Range	OL Reading	Resolution	Accuracy
100.00Hz	100.00Hz	0.01Hz	±(0.3% + 3D)
1000.0Hz	1000.0Hz	0.1Hz	
10.000kHz	10.000kHz	0.001kHz	

**Minimum Sensitivity :**

&gt; 5V (for ACV 1Hz ~ 10kHz)

&gt; 8A (for ACA 1Hz ~ 1kHz)

**Minimum Frequency : 1Hz****Overload Protection :** AC/DC 1000V and 600A**(13) HFR (High Frequency Rejection)**

Available for ACV, ACA and, Flexible Current Probe.

Add ± 4% to specified accuracy of each function and each range for 45Hz to 200Hz.

Accuracy is unspecified for &gt; 200Hz.

Cut-off Frequency (-3dB) : 800Hz

**(14) Inrush Current**

Available for ACA and Flexible Current Probe.

Trigger level : ≥50d.

Add ± 3% to specified accuracy of each function and each range.

**(15) Resistance**

Range	OL Reading	Resolution	Accuracy
600.0Ω	660.0Ω	0.1Ω	±(0.9% + 5D)
6.000kΩ	6.600kΩ	0.001kΩ	±(0.9% + 2D)
60.00kΩ	66.00kΩ	0.00kΩ	
600.0kΩ	660.0kΩ	0.1kΩ	

To get more accuracy result, short the test probes to obtain the offset. The accuracy specification is specified for the result that the offset is subtracted.

**Overload Protection :** AC/DC 1000V**(16) Continuity**

Built-in buzzer sounds when measured resistance is less than 20Ω and sounds off when measured resistance is more than 200Ω, Between 20Ω to 200Ω the buzzer maybe sound or off either.

**Continuity Indicator :** 2.7K Tone Buzzer**Response Time of Buzzer :** < 100msec.**Overload Protection :** AC/DC 1000V**(17) Diode**

Range	OL Reading	Resolution	Accuracy
1.500V	1.550V	0.001V	±(0.9% + 2D)

**Open Circuit Voltage :** Approx. 1.8V**Overload Protection :** AC/DC 1000V.

## (18) Capacitance

Range	OL Reading	Resolution	Accuracy
100.0 $\mu$ F	110.0 $\mu$ F	0.1 $\mu$ F	$\pm(1.9\% + 2D)$
1000 $\mu$ F	1100 $\mu$ F	1 $\mu$ F	

**Overload Protection** : AC/DC 1000V

## (19) VoltSeek

**Voltage Range of High Sensitivity** : 80V ~ 1000V (At the top edge of the jaw)

**Voltage Range of Low Sensitivity** : 160V ~ 1000V (At the top edge of the jaw)

## (20) Temperature

Range	OL Reading	Resolution	Accuracy
-40.0°C – 400.0°C	440.0°C	0.1°C	$\pm(1\% + 20D)$
-40.0°F – 752.0°F	824.0°F	0.1°F	$\pm(1\% + 36D)$

The accuracy does not include the accuracy of the thermocouple probe.

Accuracy specification assumes surrounding temperature stable to  $\pm 1^\circ\text{C}$ . For surrounding temperature changes of  $\pm 2^\circ\text{C}$ , rated accuracy applies after 2 hours.

**Overload Protection** : AC/DC 1000V

## ATL-PV Test Leads Instruction

## Probe tip guard cap

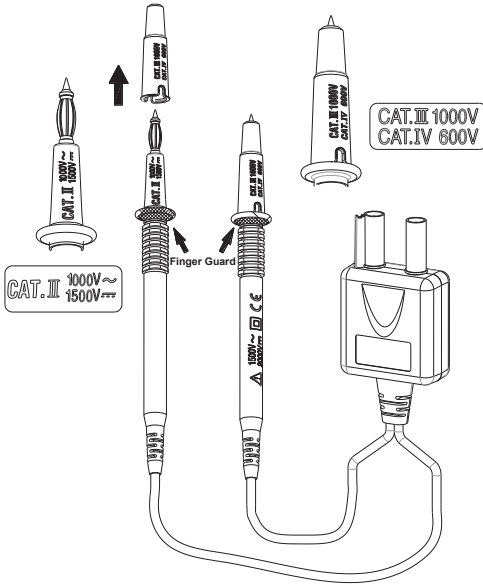

For CAT III or CAT IV environments, use the test leads with the probe tip guard cap fixed firmly. Without the probe tip guard cap, the test leads can be used in CAT II environment ONLY.

For 1500V AC & 2000V DC measurement, This test lead can only be used in the environment that is not connected to MAINS directly.

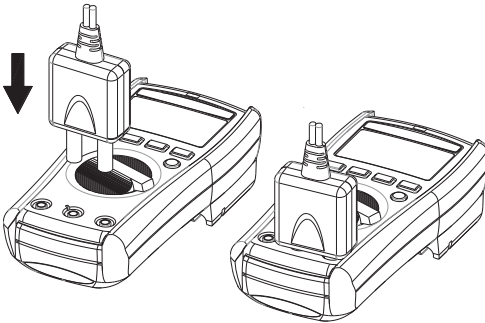

**⚠ CAUTION**

Make sure that test leads are firmly connected to the V-COM terminals of the correct instrument, and the instrument have to switch to PV mode.

### CAUTION

- When using test leads or probes, keep your fingers behind the finger guards.
- Use caution with voltages above 30 Vac rms, 42 Vac peak, or 60 Vdc. These voltages pose a shock hazard.
- If the test lead is used in a manner not specified by the manufacturer, the protection provided by the equipment may be impaired.
- To reduce the risk of fire or electric shock, do not use this product around explosive gas or in damp locations.
- DO NOT USE the test leads when the internal white insulation layer is exposed.
- DO NOT USE the test leads above maximum ratings of CAT, environment, voltage and current, that are indicated on the probe and the probe tip guard cap.
- DO NOT USE the test leads without the probe tip guard cap in CAT III and CAT IV environments.
- DO NOT USE the test leads to measure over 1000V that is connected to MAINS directly.

### Maintenance

Do not attempt to repair this test lead set. It contains no user-serviceable parts. Repair or servicing should only be performed by qualified personnel.

### Cleaning

Clean the test lead with a water and mild detergent. DO NOT use abrasives or solvents and DO NOT IMMERSE in liquid.

### Specification

**Input Impedance:** 10M $\Omega$

**Overvoltage Category:** CAT 0 1500V AC, 2000V DC  
 CAT II 1000V AC, 1500V DC  
 CAT III 1000V, CAT IV 600V.

**Pollution Degree 2**

**Exposed probe tip length :** 19 mm to 4 mm (0.75 inch to 0.16 inch)

**Environmental ratings :** -10°C to 45°C (-4°F to 113°F), 80% R.H.









**Altitude :** 2000 m (6,562 ft)

**Safety Standard :** EN61010-031

### CAT Application field

0	Circuits that are not directly connected to Mains
II	The circuits directly connected to Low-voltage installation.
III	The building installation.
IV	The source of the Low-voltage installation.

### Symbols as marked on the test lead and Instruction card

	Risk of electric shock		See instruction Card
	DC measurement		AC measurement
	Earth ground		Both direct and alternating current
	Conforms to EU directives		Equipment protected by double or reinforced insulation