

Specification for Speaker	Page	2/9
Model No. : KP3040SP1	Revision No.	1.0
	Drawing No.	KFC3574

CONTENTS

1. Scope
2. General
3. Electrical and Acoustic Characteristics.
4. Reliability Test
5. Measurement Block Diagram & Response curve
6. Structure
7. Dimensions.
8. Packing

Specification for Speaker		Page	3/9
		Revision No.	1.0
Model No. :	KP3040SP1	Drawing No.	KFC3574

1. Scope

This specification is applied to the two side dynamic speaker which is used all of the electrical acoustic product.

- compact, rich sound
- applications: mobile phone, PDA, notebook computer, etc. ..

2. General

- 2.1 Out-Diameter : Ø30 mm
- 2.2 Height : 4.0mm
- 2.3 Weight : 6.0gr.
- 2.4 Operating Temperature range:
-20~+60°C without loss of function
- 2.5 Store Temperature range:
-25~+60°C without loss of function

3. Electrical and Acoustic Characteristics.

Test condition : 15 ~ 35 °C, 25% ~ 85% RH, 860~1060 mbar

3.1 Speaker

	Items	Specification
1	Impedance	8 Ω ± 15%(at 1Vrms,1.5kHz)
2	Sound Pressure Level	90dB ± 3dB(1kHz/0.1W/0.1M)
3	Resonance Frequency	650Hz ± 15%
4	Frequency Range	F ₀ ~ 7.0kHz
5	Input Power	Rated 0.8W / Max. 1.5W
6	Distortion	<10% Max. at 2kHz/2Vrms
7	Buzz and Rattle	Should not be audible buzzes,rattles when the 2.5V sine wave signal swept at frequency range.
8	Polarity	When supplied plus D.C. voltage to (+) terminal, the cone diaphragm must move to forward.

Specification for Speaker		Page	4/9
		Revision No.	1.0
Model No. :	KP3040SP1	Drawing No.	KFC3574

4. Reliability Test

After test(1~7item), the speaker S.P.L . difference shall be within $\pm 3\text{dB}$, and the appearance not exist any change to be harmful to normal operation(e.g. cracks,rusts,damages and especially distortion).

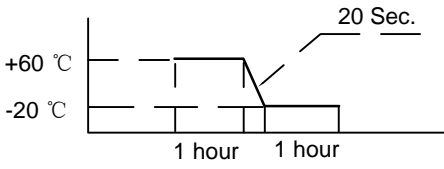
	Item	Specification
1	High Temperature Test	After being placed in a chamber with $+60\pm 3\text{ }^\circ\text{C}$ for 96 hours and then being placed in natural condition for 1 hour, speaker shall be measured.
2	Low Temperature Test	After being placed in a chamber with $-20\pm 3\text{ }^\circ\text{C}$ for 96 hours and then being placed in natural condition for 1 hour, speaker shall be measured.
3	Humidity Test	After being placed in a chamber with 60 to 90%R.H. at $+40\pm 2\text{ }^\circ\text{C}$ for 96 hours and then being placed in natural condition for 1 hour, speaker shall be measured.
4	Thermal Shock Test	<p>After being placed in a chamber at $+60\text{ }^\circ\text{C}$ for 1 hour, then speaker shall be placed in a chamber at $-20\text{ }^\circ\text{C}$ for 1 hour(1 cycle is the below diagram).</p> <p>After 6 above cycles, speaker shall be measured after being placed in natural condition for 1 hour.</p>  <p>The diagram shows a temperature profile starting at $+60\text{ }^\circ\text{C}$ for a 1-hour dwell. It then ramps down to $-20\text{ }^\circ\text{C}$ over a 20-second period, followed by a 1-hour dwell at $-20\text{ }^\circ\text{C}$.</p>
5	Vibration Test	After being applied vibration of amplitude of 1.5mm with 10 to 55Hz band of vibration frequency to each of 3 perpendicular directions for 1 hour, then placed in natural condition for 1 hour, speaker shall be measured.
6	Drop Test	The speaker when mounted in the jig which weight 85g~100g, shall with stand 15 times random drops from a height of 1.5 meter to a concrete floor faced with 5mm thick hard wood board.and be nothing mechanical damage.
7	Load test	After being applied loading white noise with input power 0.8W(2.5Vrms.) for 96 hours, then placed in natural condition for 1 hour, speaker shall be measured.
8	Insulation test	When they are measured with DC 100V the insulation resistance between v.c. terminal and frame must be more than $1\text{ M}\Omega$

Specification for Speaker		Page	5/9
Model No. : KP3040SP1		Revision No.	1.0
		Drawing No.	KFC3574

5. Measurement Block Diagram & Response curve

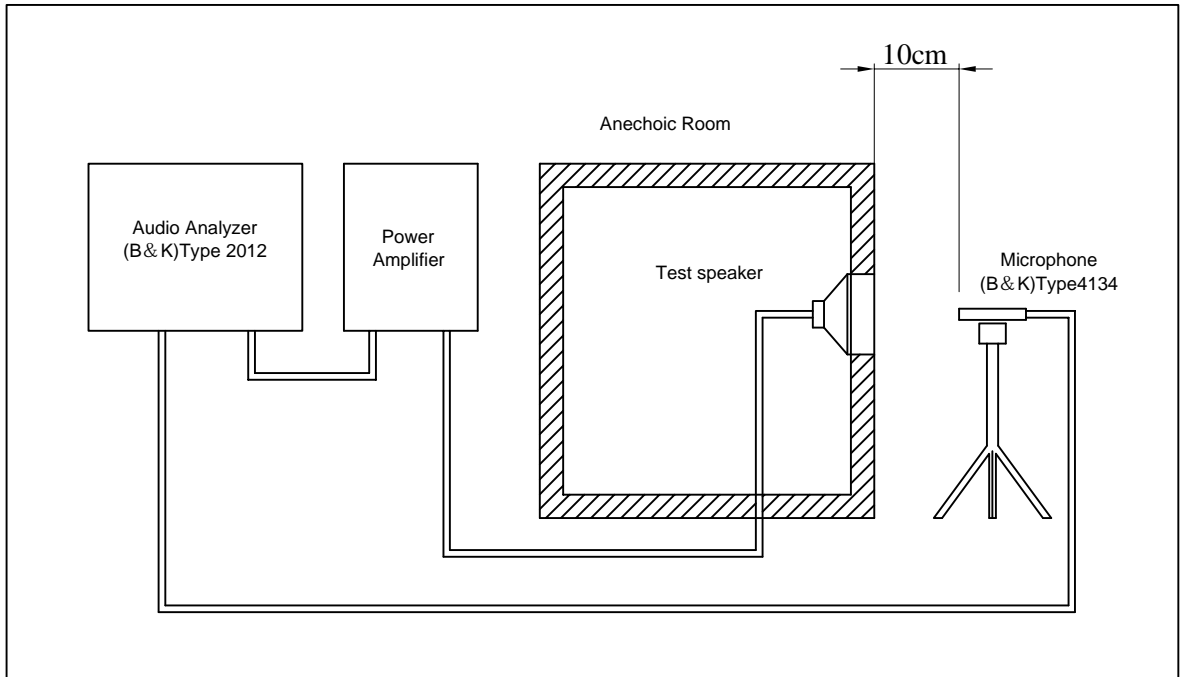

Specification for Speaker		Page	6/9
		Revision No.	1.0
Model No. :	KP3040SP1	Drawing No.	KFC3574

6. Structure

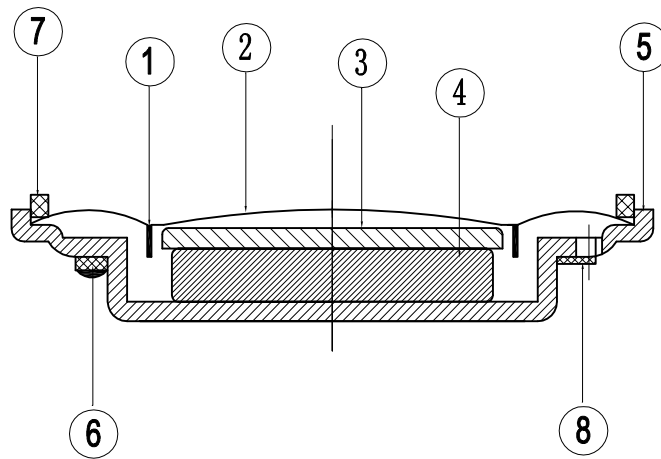

8	Screen	1	Fabric	
7	Gasket	1	paper	
6	Terminal	1	Epoxy PCB	
5	Frame	1	SPC	
4	Magnet	1	Nd-Fe-B	
3	Plate	1	SPC	
2	Diaphragm	1	Film	
1	Voice Coil	1	Copper	
No.	Part Name	Q'TY	Material	Remarks

Specification for Speaker	Page	7/9
	Revision No.	1.0
Model No. : KP3040SP1	Drawing No.	KFC3574

7. Dimensions

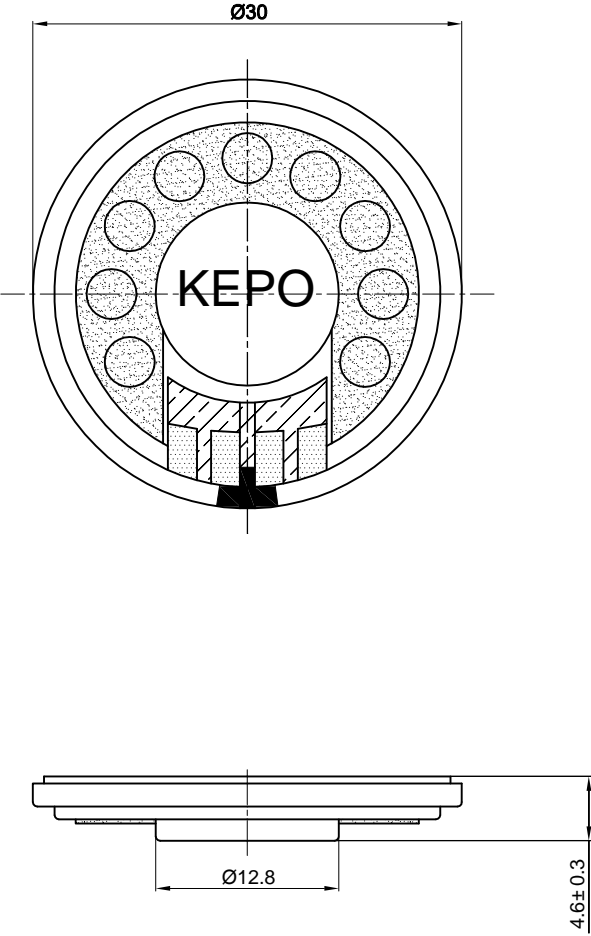

FIRST ANGLE PROJECTION

UNIT : mm
Tolerance : ± 0.5

Specification for Speaker	Page	8/9
	Revision No.	1.0
Model No. : KP3040SP1	Drawing No.	KFC3574

8. Packing

Each minimum package unit of products shall be in a carton box and it shall be clearly marked with Part Number, quantity and outgoing inspection number.

There shall be no mechanical damage on products during transportation and/or in storage.