

AN6387

VCR Cylinder Direct Motor Drive Circuit

■ Outline

The AN6387 is an integrated circuit designed to drive a VCR cylinder DD motor.

■ Features

- The functions consist of :
 - 3-Phase motor drive circuit
 - 2-Phase Hall element input circuit
 - PG, FG, generator circuit
 - Motor lock detector
- Supply voltage : either 9V or 12V

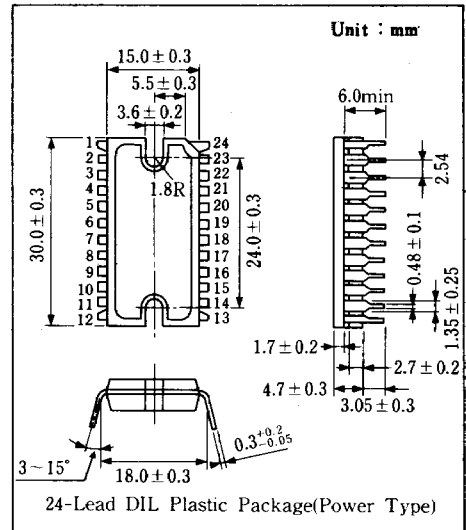

■ Block Diagram

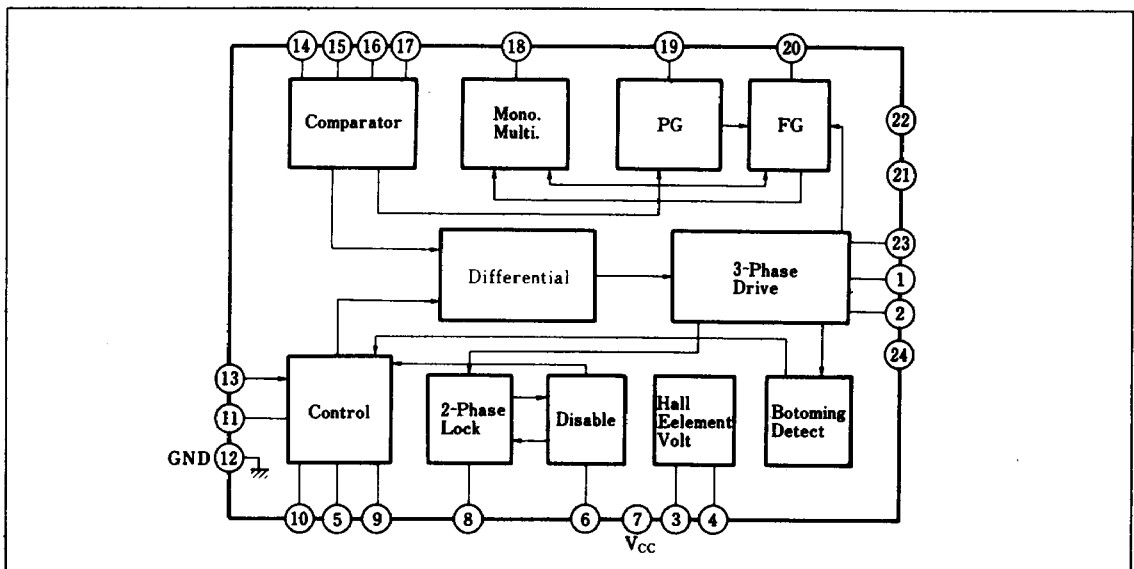

■ Pin

Pin No.	Pin Name	Pin No.	Pin Name
1	Motor Current (2)	13	Torque Direct Voltage
2	Output (3)	14	(1)
3	Hall Element Ref. Voltage	15	Hall Element (2)
4	Hall Element Voltage	16	Voltage Input (3)
5	Motor Current Detect	17	(4)
6	Disable	18	MM Output
7	V _{CC}	19	PG Output
8	Lock Detect	20	FG Output
9	Phase Compensation	21	V _M
10	Phase Compensation	22	NC
11	Servo Ref. Voltage	23	Motor Current Output(1)
12	GND	24	Motor Current

■ Absolute Maximum Ratings (Ta = 25°C)

Item	Symbol	Rating	Unit	Note
Supply Voltage	V _{CC}	14.4	V	
Circuit Voltage	V _{n-12}	0 40	V	n=1,2,23
Circuit Voltage	V ₂₁₋₁₂	0 24	V	
Circuit Current	I _n	0 1500	mA	n=1,2,23
Power Dissipation	P _D	10	W	
Operating Ambient Temperature	V _{OPR}	-20 ~ +70	°C	
Storage Temperature	T _{stg}	-40 ~ +150	°C	

■ Electrical Characteristics (Ta = 25°C ± 2°C)

Item	Symbol	Test Circuit	Condition	min.	typ.	max.	Unit
Total Current	I _{tot}	1	V _{CC} = 9V, disable	4.0		20	mA
ET-ATC Transfer Gain	G _(TO)	2	V _{CC} = 9V	0.86		1.06	
ATC Limit Voltage	V _(lim)	2	V _{CC} = 9V, at full-torque command	0.44		0.50	V
Saturation Detect Gain	G _(S)	3	V _{CC} = 9V, R _d = 0.47Ω	0.5		1.5	
Saturation Detect Start Voltage	V _(Det 1)	3	V _{CC} = 9V, R _d = 0.47Ω	1.0		1.8	V
Saturation Detect End Voltage	V _(Det 2)	3	V _{CC} = 9V, R _d = 0.47Ω	0.5		1.0	V
HV Output Voltage	V _{HV}	1	V _{CC} = 9V, V _{SV} = 2.6V, R _{HV} = 270Ω	2.1			V
HV Protect Voltage	V _(Protect)	1	V _{CC} = 9V, V _{SV} = V _{CC}	3.5		4.3	V
DS Level Voltage	V _{DS}	2	V _{CC} = 9V			1.2	V
ETR Voltage	V _{ETR}	2	V _{CC} = 9V	4.3		4.7	V
HEM, HEM, HES, HES Bias Current	I _{Bias}	2	V _{CC} = 9V	-6			μA
HES-HES Comparator Offset Voltage	V _{I(offset)S}	2	V _{CC} = 9V	-6		6	mV
HEM-HEM Comparator Offset Voltage	V _{I(offset)M}	2	V _{CC} = 9V	-6		6	mV
PG Lowest Voltage	V _{OL19}	2	V _{CC} = 9V, 47kΩ applied to Pin⑱ → 5V			0.5	V
FG Lowest Voltage	V _{OL29}	4	V _{CC} = 9V, 47kΩ applied to Pin⑳ → 5V			0.5	V
BEF Fetch Voltage	V _{BFG}	4	V _{CC} = V _M = 9V	0.6		1.0	V

Note: Operating Supply Voltage Range : V_{CC(OPR)} = 8 ~ 13V (V₇₋₁₂)

Test Circuit 1 (I_{tot} , V_{HV} , $V_{Protect}$)

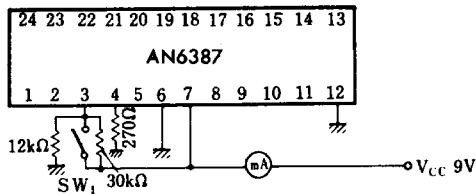

SW₁: Open, Current Value I_{CC}
 SW₁: Open, Pin ③ Voltage 2.6V...
 Pin④ Voltage V_{HV}
 SW₁: Short, Pin ④ Voltage...V_(Protect)

Test Circuit 2 (G_{IO} , $V_{(lim)}$, V_{DS} , V_{ETR} , I_{Bias} , $V_{I(offset)S}$, $V_{I(offset)M}$, V_{OL19})

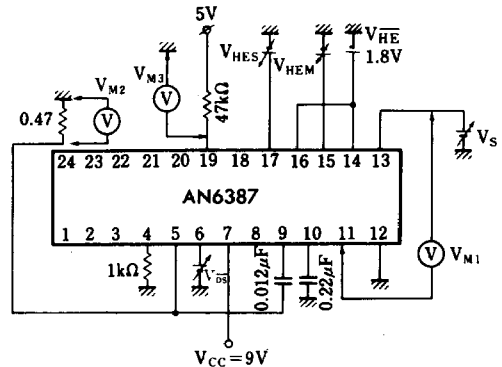

Read V_{M1} and V_{M2} when $V_{HES} = V_{HEM} = 2V$, $V_{DS} = 2V$ and $V_S = 0 \sim 6V$.

G_{IO} , $V_{(lim)}$
 (V_{HES} , V_{HEM} , V_{HF} current... I_{Bias})
 Read V_{M1} when $V_S = 0V$ $-V_{ETR}$
 $V_{HES} = V_{HEM} = 2V$, $V_{DS} = 2V$
 Continuously lowering V_{HES} from 2V, the voltage of $V_{MES} - V_{HF}$ when V_{M3} went down : $V_{I(offset)S}$
 Next, continuously lowering V_{HEM} from 2V, the voltage of $V_{HEM} - V_{HF}$ when V_{M3} went down : $V_{I(offset)M}$, and lowest voltage of V_{M3} ... V_{OL19}

Test Circuit 3 (G_{S} , $V_{(Det.1)}$, $V_{(Det.2)}$)

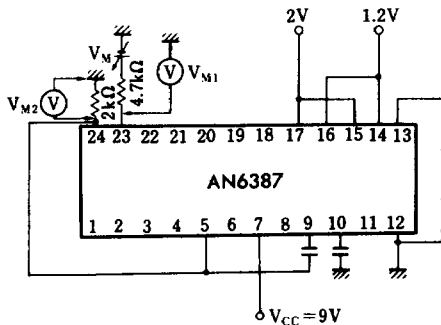

Set V_M at 2V. Continuously increase V_M until it is as shown in the figure below.

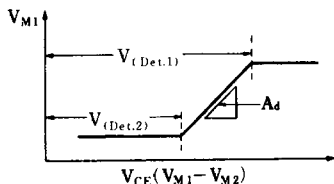

Test Circuit 4 (V_{OL20} , V_{BFG})

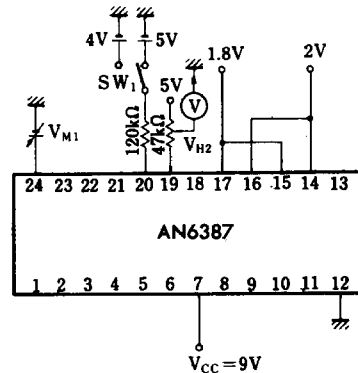

When $S_1 = 5V$ and $V_{M1} = 9V$, V_{M2} ...High voltage
 When $S_1 = 4V$ and $V_{M1} = 9V$, V_{M2} ...Low voltage...
 V_{OL20} . At this time, continuously increase V_{M1} up to 10V.
 Next, when V_{M1} continuously lowering for $S_1 = 5V$, the voltage of V_{M1} when V_{M2} became High voltage ... V_{BFG}

