

AN5136K

Color TV Video IF Amplifier, PLL, Detector, AGC, AFC, SIF, Circuit

Outline

The AN5136K is an integrated circuit designed for color TV video and audio IF signal processing circuit.

Features

- PLL true synchronous detector incorporates VCO
- Quadrature sound FM detector
- AGC defeat terminal (Pin ⑩)

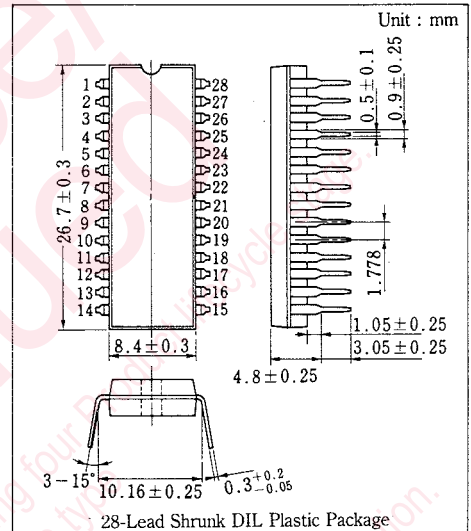

Block Diagram

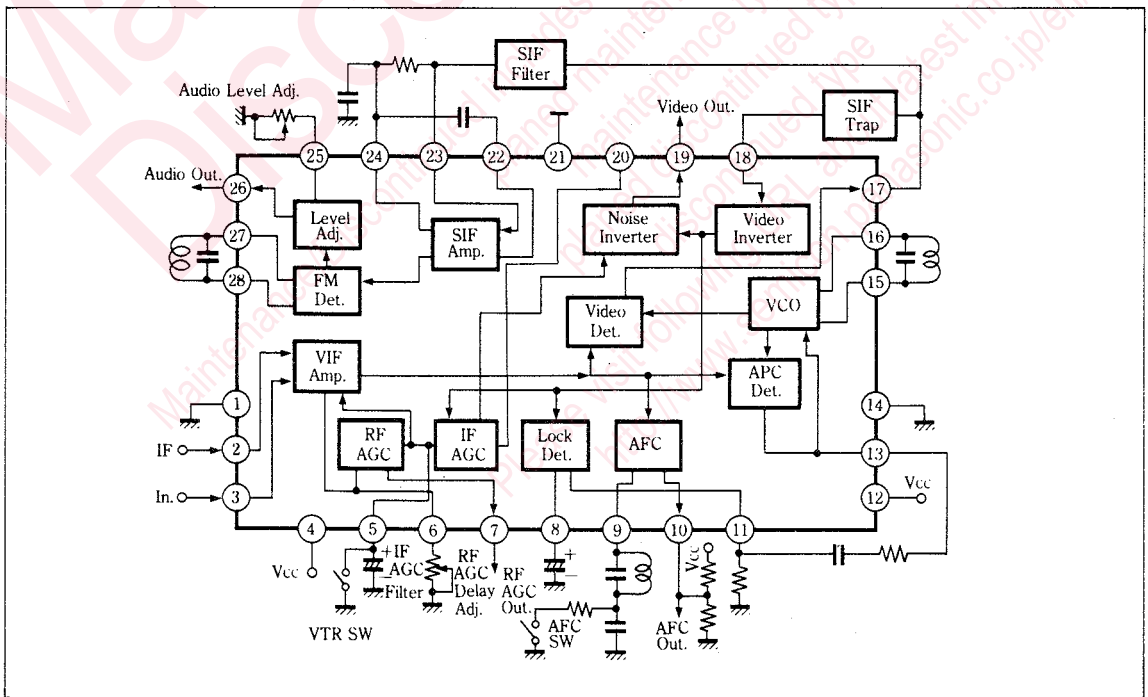

■ Absolute Maximum Ratings (Ta=25°C)

Item		Symbol	Rating		Unit
Voltage	Supply Voltage	V _{CC}	13.8		V
	Circuit Voltage	V _{5-1,14,21}	V _{4,12-1,14,21}	0	V
		V _{6-1,14,21}	V _{4,12-1,14,21}	0	V
		V _{7-1,14,21}	V _{4,12-1,14,21}	0	V
		V _{10-1,14,21}	V _{4,12-1,14,21}	0	V
		V _{18-1,14,21}	V _{4,12-1,14,21}	0	V
	V _{25-1,14,21}	8.0	0	V	
Current	Circuit Current	I ₁₇	- 7	+0.5	mA
		I ₁₉	- 7	+0.5	mA
		I ₂₈	- 5	+0.5	mA
Power Dissipation (Ta=70°C)		P _D	1300		mW
Temperature	Operating Ambient Temperature	T _{opr}	-20~+70		°C
	Storage Temperature	T _{stg}	-55~+150		°C

■ Electrical Characteristics (Ta=25°C)

Item	Symbol	Test Circuit	Condition	min.	typ.	max.	Unit
IF Amplifier · Detection · AGC · AFC Circuit							
Video Detector Output	V _O	1	f=58.75MHz, V _i =80dBμ, m=87.5%	1.8	2.1	2.4	V _{P-P}
Input Sensitivity	S _(IN)	1	V _O =-3dB	49	53	57	dBμ
Max. Allowable Input	V _(Imax)	1		103	108		dBμ
Differential Gain	DG	1	f=58.75MHz, V _i =80dBμ, m=87.5%		2	6	%
Differential Phase	DP	1	f=58.75MHz, V _i =80dBμ, m=87.5%		2	5	deg
Frequency Characteristics	f _c	1	V _O =-3dB	4.5	5	6	MHz
RF AGC Gain	G _{RFAGC}	1	f=10kHz, V _i =10mV	40	44	48	dB
AFC Phase Detector Sensitivity	μ	1	R _L =68kΩ // 82kΩ	30	40	60	mV/kHz
AFC Center Voltage	V ₁₀	1	R _L =68kΩ // 82kΩ	4.2	6.5	8.2	V
VCO · APC Circuit							
VCO Max. Variable Range (1)	Δf _{V(1)}	1	V ₁₃ =2V	+0.85	+1.5	+2.5	MHz
VCO Max. Variable Range (2)	Δf _{V(2)}	1	V ₁₃ =3V	-4.0	-2.4	-1.4	MHz
VCO Control Sensitivity	β	1		3	4.5	6	kHz/mV
APC Pull-In Range (1)	f _{APC(1)}	1		+0.85	+1.5	+2.5	MHz
APC Pull-In Range (2)	f _{APC(2)}	1		-3.5	-2.5	-1.6	MHz
SIF Circuit							
Total Detector Output	V _O	2	f ₀ =4.5MHz, f _m =400Hz Δf=±25kHz, V _i =100mV _{rms}	400	500	600	mV _{rms}
Input Limiting Voltage	V _(lim)	2	f ₀ =4.5MHz, f _m =400Hz Δf=±25kHz		36	40	dBμ
DC Characteristics							
Circuit Current	I _{4+I₁₂}			50	70	90	mA

Test Circuit 1 (V_O , $S_{(IN)}$, $V_{I(max)}$, DG, DP, f_C , G_{RFAGC} , μ , V_{I0} , $\Delta f_{V(1)}$, $\Delta f_{V(2)}$, β , $f_{APC(1)}$, $f_{APC(2)}$)

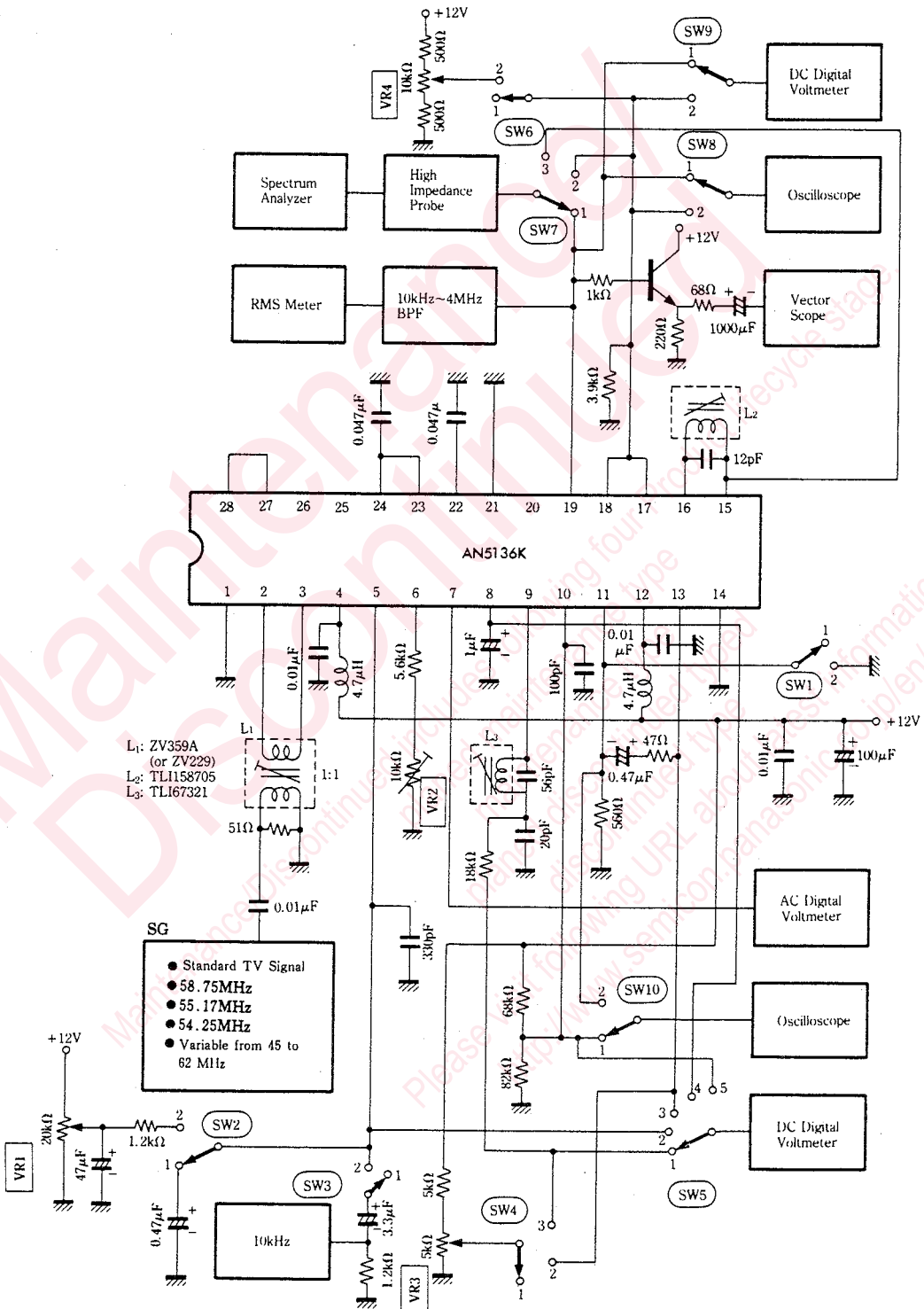

Signal	Input Signal		Measuring Procedure	Measurement	SW Condition									
	Type	Input Level			1	2	3	4	5	6	7	8	9	
V_o	f_{STD} $m=87.5\%$	80dB μ	—	Oscilloscope Output Amplitude	1	1	1	1	1	1	1	1	1	1
$S_{(N)}$	f_{STD} $m=87.5\%$	80dB μ	Input Level Attenuation	Oscilloscope Output Amplitude	1	1	1	1	1	1	1	1	1	1
$V_{i(lim)}$	f_{STD} $m=87.5\%$	80dB μ	Input Level Increase	Oscilloscope Output Amplitude	1	1	1	1	1	1	1	1	1	1
DG	f_{STD} (Staircase) $m=87.5\%$	80dB μ	—	Vector Scope DG	1	1	1	1	1	1	1	1	1	1
DP	f_{STD} (Staircase) $m=87.5\%$	80dB μ	—	Vector Scope DP	1	1	1	1	1	1	1	1	1	1
f_c	f_o f_m	80dB μ 60dB μ	—	Spectrum Analyzer Det. Output Frequency	1	1	1	1	1	1	1	1	1	1
G_{RFAGC}	f_{10K}	10mV	VR1 adj.	AC Digital Voltmeter	1	2	2	1	1	1	1	1	1	1
μ	f_{SWP}	80dB μ	—	Oscilloscope	1	1	1	1	1	1	1	1	1	1
V_{10}	No Signal	—	—	DC	1	1	1	1	1	1	1	1	1	1
$\Delta f_{(V1)}$ $\Delta f_{(V2)}$	No Signal	—	V_s held with VR1 VR3 adj.	Spectrum Analyzer VCO Frequency	1	2	1	2	3	1	1	1	1	1
β	No Signal	—	V_s held with VR1 VR3 adj.	Spectrum Analyzer VCO Frequency	1	2	1	2	3	1	1	1	1	1
$f_{APC(1)}$ $f_{APC(2)}$	f_m	80dB μ	—	Oscilloscope Input Signal Frequency	1	1	1	1	3	1	1	1	1	1

• f_{STD} : Standard TV signal • f_o : 58.75MHz • f_{10K} : 10kHz • f_m : Variable Frequency • f_{swp} : Sweep Signal

Test Circuit 2 (V_o , $V_{i(lim)}$)

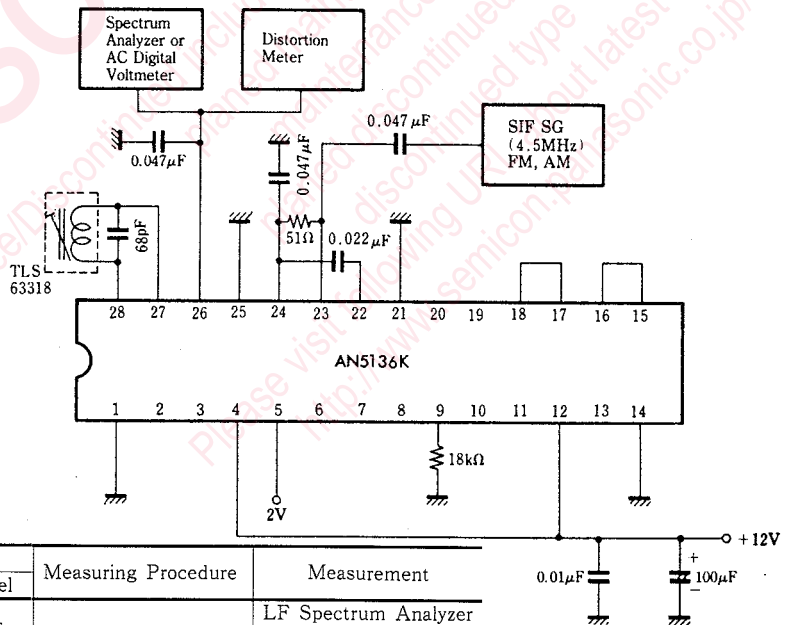

Signal	Input Signal		Measuring Procedure	Measurement
	Type	Input Level		
V_o	FM $\Delta f = \pm 25kHz$	100mVrms	—	LF Spectrum Analyzer or AC Digital Voltmeter
$V_{i(lim)}$	FM $\Delta f = \pm 25kHz$	100mVrms	Input Level Attenuation	LF Spectrum Analyzer or AC Digital Voltmeter

■ Pin

Pin No.	Pin Name	Pin No.	Pin Name
1	GND	15	VCO Coil
2	IF Input	16	VCO Coil
3	IF Input	17	Det. Output
4	V _{cc}	18	Video Input
5	IF AGC Filter	19	Video Output
6	RF AGC Delay Adj.	20	AGC Defeat
7	RF AGC Output	21	GND
8	Lock Det. Filter	22	SIF Input Bias
9	AFC Coil	23	SIF Input
10	AFC Output	24	SIF Input Bias
11	APC Filter SW	25	Sound Output Level Adj.
12	V _{cc} (VCO)	26	Sound Output
13	APC Filter	27	SIF Coil
14	GND (VCO)	28	SIF Coil

Reference: Different Point in the AN5135NK/the AN5138NK and the AN5136K and the AN5137K

Item	AN5135NK/5138NK	AN5136K	AN5137K
Pin ⑩	Video f. Characteristics Compensating Terminal	AGC Defeat Terminal	IF AGC Input Terminal
Video Output Polarity (Pin ⑨)	Positive Polarity (\surd)	Negative Polarity (\frown)	Negative Polarity (\frown)
Audio Output Polarity (S Curve)	Positive Polarity (\surd)	Negative Polarity (\frown)	Negative Polarity (\frown)
VTR SW	Available	Not Available	Not Available
Applications	TV and Video Use	TV Use	CATV Discrumble Use

Request for your special attention and precautions in using the technical information and semiconductors described in this book

- (1) If any of the products or technical information described in this book is to be exported or provided to non-residents, the laws and regulations of the exporting country, especially, those with regard to security export control, must be observed.
- (2) The technical information described in this book is intended only to show the main characteristics and application circuit examples of the products. No license is granted in and to any intellectual property right or other right owned by Panasonic Corporation or any other company. Therefore, no responsibility is assumed by our company as to the infringement upon any such right owned by any other company which may arise as a result of the use of technical information described in this book.
- (3) The products described in this book are intended to be used for standard applications or general electronic equipment (such as office equipment, communications equipment, measuring instruments and household appliances).
Consult our sales staff in advance for information on the following applications:
 - Special applications (such as for airplanes, aerospace, automobiles, traffic control equipment, combustion equipment, life support systems and safety devices) in which exceptional quality and reliability are required, or if the failure or malfunction of the products may directly jeopardize life or harm the human body.
 - Any applications other than the standard applications intended.
- (4) The products and product specifications described in this book are subject to change without notice for modification and/or improvement. At the final stage of your design, purchasing, or use of the products, therefore, ask for the most up-to-date Product Standards in advance to make sure that the latest specifications satisfy your requirements.
- (5) When designing your equipment, comply with the range of absolute maximum rating and the guaranteed operating conditions (operating power supply voltage and operating environment etc.). Especially, please be careful not to exceed the range of absolute maximum rating on the transient state, such as power-on, power-off and mode-switching. Otherwise, we will not be liable for any defect which may arise later in your equipment.
 - Even when the products are used within the guaranteed values, take into the consideration of incidence of break down and failure mode, possible to occur to semiconductor products. Measures on the systems such as redundant design, arresting the spread of fire or preventing glitch are recommended in order to prevent physical injury, fire, social damages, for example, by using the products.
- (6) Comply with the instructions for use in order to prevent breakdown and characteristics change due to external factors (ESD, EOS, thermal stress and mechanical stress) at the time of handling, mounting or at customer's process. When using products for which damp-proof packing is required, satisfy the conditions, such as shelf life and the elapsed time since first opening the packages.
- (7) This book may be not reprinted or reproduced whether wholly or partially, without the prior written permission of our company.

This datasheet has been downloaded from:

www.DatasheetCatalog.com

Datasheets for electronic components.