

3V/230mW Power Amplifier BA515

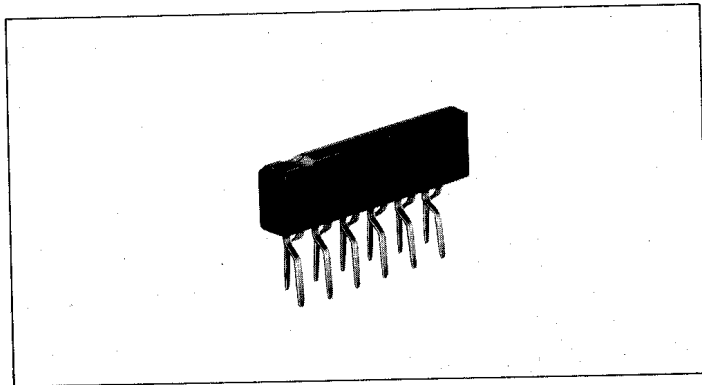

Dimensions (mm)

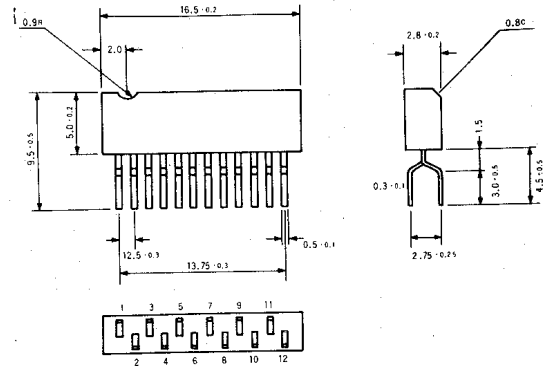

Fig. 1

The BA515 is a monolithic integrated circuit consisting of an OTL power amplifier developed for use in 3V tape recorders. It can be used in OTL configuration at low voltages and, when compared with OT type circuits, provides stable feedback and excellent distortion versus frequency characteristics. In addition, it requires few externally connected components thus contributing to the compact design and simplification of electronic tape recorders. The internal circuit of the BA515 makes use of the OTL configuration, a system thought previously to be unsuited to 3V equipment, and provides a compensating circuit for operation at low voltages, thereby achieving a starting voltage of 1.5V or less. To establish the ALC operating characteristics for recording, a partially built-in ALC circuit is used to apply ALC control for even recording output in the 0.4V range. Thus, for operation below even 2V, sufficient recording and playback characteristics are achievable, enabling the drive of 4Ω speakers with the rated output power. The output of 230mW (3V operations/4Ω load, EIAJ) is sufficient to drive speakers, and the pop noise occurring upon power application, motor noise and supply ripple rejection characteristics have been taken into consideration in this design. To allow use at low voltages and in particular AC adaptors where misuse can apply excessive voltages, protection from such conditions is provided by a special built-in protective circuit. In addition, the compact, 12-pin zig-zag package is formed to increase mounting density.

Features

1. Rated output power of 230mW with a supply voltage of 3V ($R_L = 4\Omega$, THD = 10%)
2. Partially built-in ALC circuit enables ALC operation at voltages even below 2V.
3. A built-in protective circuit prevents destruction by excessive voltages and is able to withstand misuse of AC adaptors in the range 6~15V.
4. Housed in a compact 12-pin formed package
5. Prevention of pop noise occurring on power application has been included.
6. High ripple rejection ratio

Applications

1. Microcassette tape recorders
2. 3V Mini-cassette tape recorders
3. Ultra-thin radios

Circuit Diagram

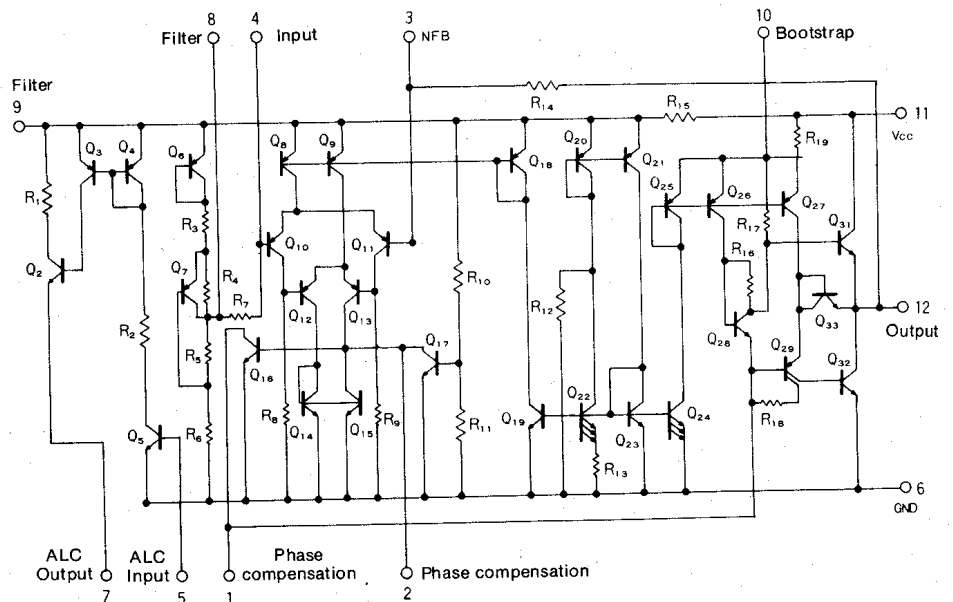

Fig. 2

Absolute Maximum Ratings ($T_a = 25^\circ\text{C}$)

Parameter	Symbol	Limits	Unit
Supply voltage	V_{CC}	15	V
Power dissipation	P_d	500*	mW
Operating temperature	T_{opr}	-10~+65	$^\circ\text{C}$
Storage temperature	T_{stg}	-30~+125	$^\circ\text{C}$

* Derating is done at 5mW/ $^\circ\text{C}$ for operation above $T_a = 25^\circ\text{C}$.

Electrical Characteristics ($T_a = 25^\circ\text{C}$, $V_{CC} = 3\text{V}$, $R_L = 4\Omega$, $f = 1\text{kHz}$)

Parameter	Symbol	Min	Typ	Max	Unit	Conditions	Test circuit
Quiescent current	I_Q	—	12	—	mA		Fig. 13
Closed-loop voltage gain	G_{VC}	33	36	39	dB	$R_{NF} = 270\Omega$	Fig. 13
Rated output power	P_{OUT}	180	230	—	mW	THD = 10%	Fig. 13
Total harmonic distortion	THD	—	0.4	2.0	%	$P_O = 50\text{mW}$	Fig. 13
Output noise voltage	V_{NO}	—	0.1	1.0	mVrms	$R_g = 0\Omega$	Fig. 13
Input resistance	R_{IN}	10	20	—	k Ω		Fig. 13
Ripple rejection ratio	RR	25	40	—	dB	$R_g = 0\Omega$, $f = 100\text{Hz}$	Fig. 13
Starting voltage	V_S	1.5	—	—	V	$V_O = 50\text{mV}$	Fig. 13
ALC Transistor base current	I_{BOFF}	—	—	1	μA	$S_1 = 2$	Fig. 13
ALC Transistor base current	I_{BON}	1.0	—	—	mA	$S_1 = 1$	Fig. 13

Electrical Characteristic Curves

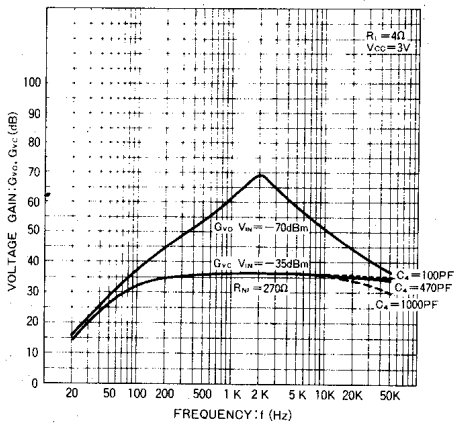

Fig. 3 Voltage gain vs. frequency

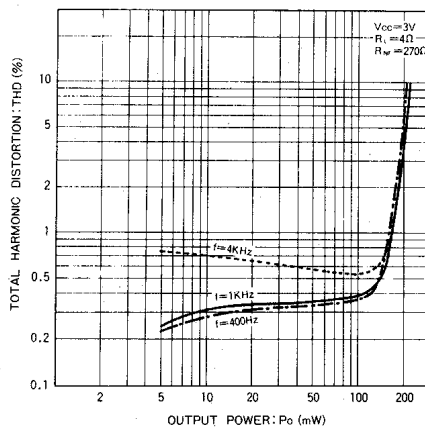

Fig. 4 Total harmonic distortion vs. output power

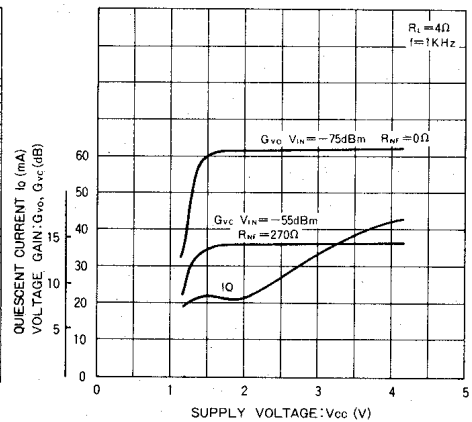

Fig. 5 Quiescent current and voltage gain vs. supply voltage

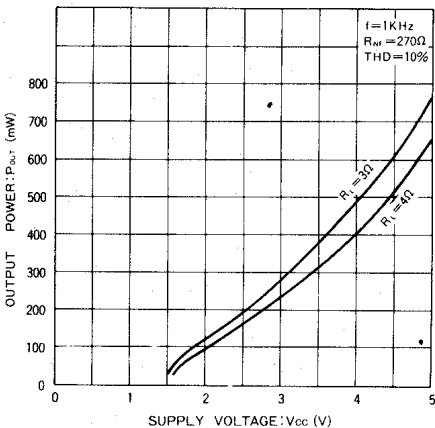

Fig. 6 Output power vs. supply voltage

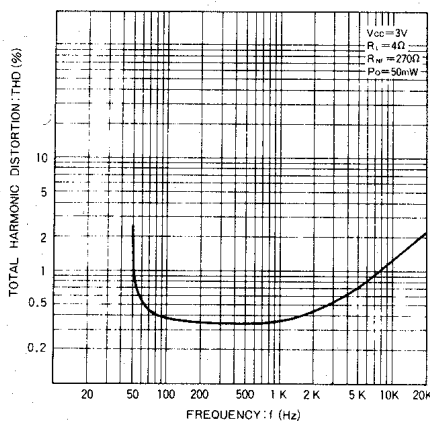

Fig. 7 Total harmonic distortion vs. frequency

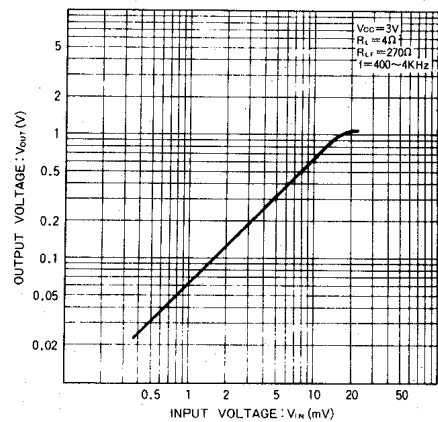

Fig. 8 Output voltage vs. input voltage