



INTEGRATED CIRCUIT

TECHNICAL DATA

TA7176AP

TOSHIBA BIPOLAR LINEAR INTEGRATED CIRCUIT

SILICON MONOLITHIC

TELEVISION SOUND SYSTEM

- Electronic Attenuator Replaces Conventional Volume Control.
- High Sensitivity : $V_{IN(lim)}=200\mu V$ (Typ.)
- Internal Zener Diode Regulated Supply
- Excellent AM Rejection : $AMR=50dB$ (Typ.)
- Low Distortion
- Audio Drive Capability $6mA_{p-p}$
- Audio Output Voltage $7V_{p-p}$

MAXIMUM RATINGS ($T_a=25^{\circ}C$)

CHARACTERISTIC	SYMBOL	RATING	UNIT
Input Voltage	V_{IN}	± 3	V
Supply Current	I_{CC}	30	mA
Power Dissipation (Note)	P_D	625	mW
Operating Temperature	T_{opr}	$-20 \sim 75$	$^{\circ}C$
Storage Temperature	T_{stg}	$-55 \sim 150$	$^{\circ}C$

(Note) Derated above $T_a=25^{\circ}C$ in the proportion of $5.0mW/^{\circ}C$

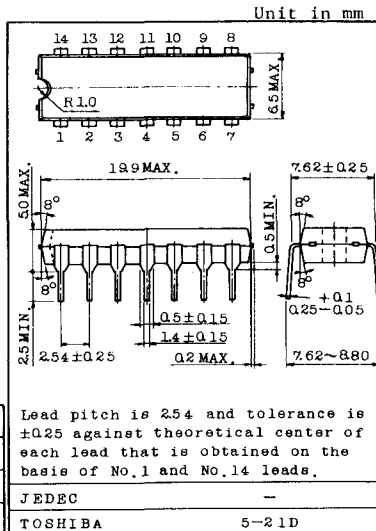

BLOCK DIAGRAM

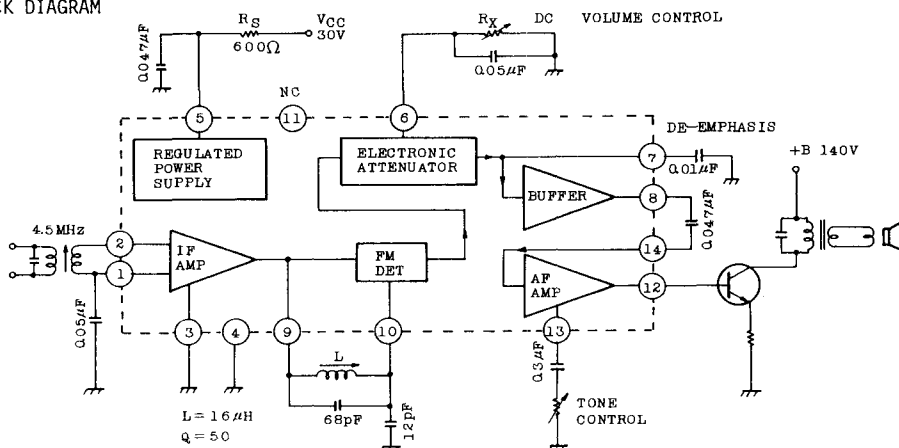



ELECTRICAL CHARACTERISTICS

(Unless otherwise specified $V_{CC}=30V$, $R_S=600\Omega$, $T_a=25^\circ C$)

CHARACTERISTIC		SYMBOL	TEST CIR-CUIT	TEST CONDITION	MIN.	TYP.	MAX.	UNIT
Zener Voltage		V_Z	-	-	10.3	11.2	12.2	V
Supply Current		I_{CC}	-	$V_S=9V$	10	16	24	mA
Power Dissipation		P_D	-	-	330	345	360	mW
Input Limiting Voltage		$V_{IN(lim)}$		$f=4.5MHz$, $f_M=400Hz$ $\Delta f=\pm 25kHz$, -3dB Limiting	-	200	400	μV
AM Rejection		AMR	1	$f=4.5MHz$, $V_{IN}=90dB\mu$ FM: $\Delta f=\pm 25kHz$ AM: 30% Modulation	40	50	-	dB
Recovered Output Voltage		V_{OD}		$f=4.5MHz$, $V_1=0.1V$	0.5	0.75	-	V_{rms}
Total Harmonic Distortion		THD(1)		$\Delta f=\pm 25kHz$, $f_M=400Hz$	-	0.9	2.0	%
Input Impedance	Parallel Input Resistance	r_{ip}	3	Measured Between Terminal No.1 & 2 $f=4.5MHz$	-	17	-	$k\Omega$
	Parallel Input Capacitance	c_{ip}			-	4	-	pF
Output Impedance	Parallel Output Resistance	r_{op}	-	Measured Between Terminal No.9 & GND $f=4.5MHz$	-	3.25	-	$k\Omega$
	Parallel Output Capacitance	c_{op}			-	7.5	-	pF
Output Impedance (PIN 7)		Z_o	-	$f=400Hz$	-	7.5	-	$k\Omega$
Output Impedance (PIN 8)		Z_o	-	$f=400Hz$	-	300	-	Ω
Max. Attenuation		ATT(Max)	1	$R_X=\infty$	60	80	-	dB
AF Voltage Gain		$G_V(AF)$	2	$V_{IN}=0.1V_{rms}$, $f=400Hz$	17.5	20	-	dB
Total Harmonic Distortion		THD(2)		$V_{OUT}=2V_{rms}$, $f=400Hz$	-	1.5	-	%
Max. Audio Output Voltage		V_{OM}		THD=5%, $f=400Hz$	2	2.5	-	V_{rms}
Input Impedance		$Z_i(AF)$	-	$f=400Hz$	-	70	-	$k\Omega$
Output Impedance		$Z_o(AF)$			-	270	-	Ω



INTEGRATED CIRCUIT

TECHNICAL DATA

TA7176AP

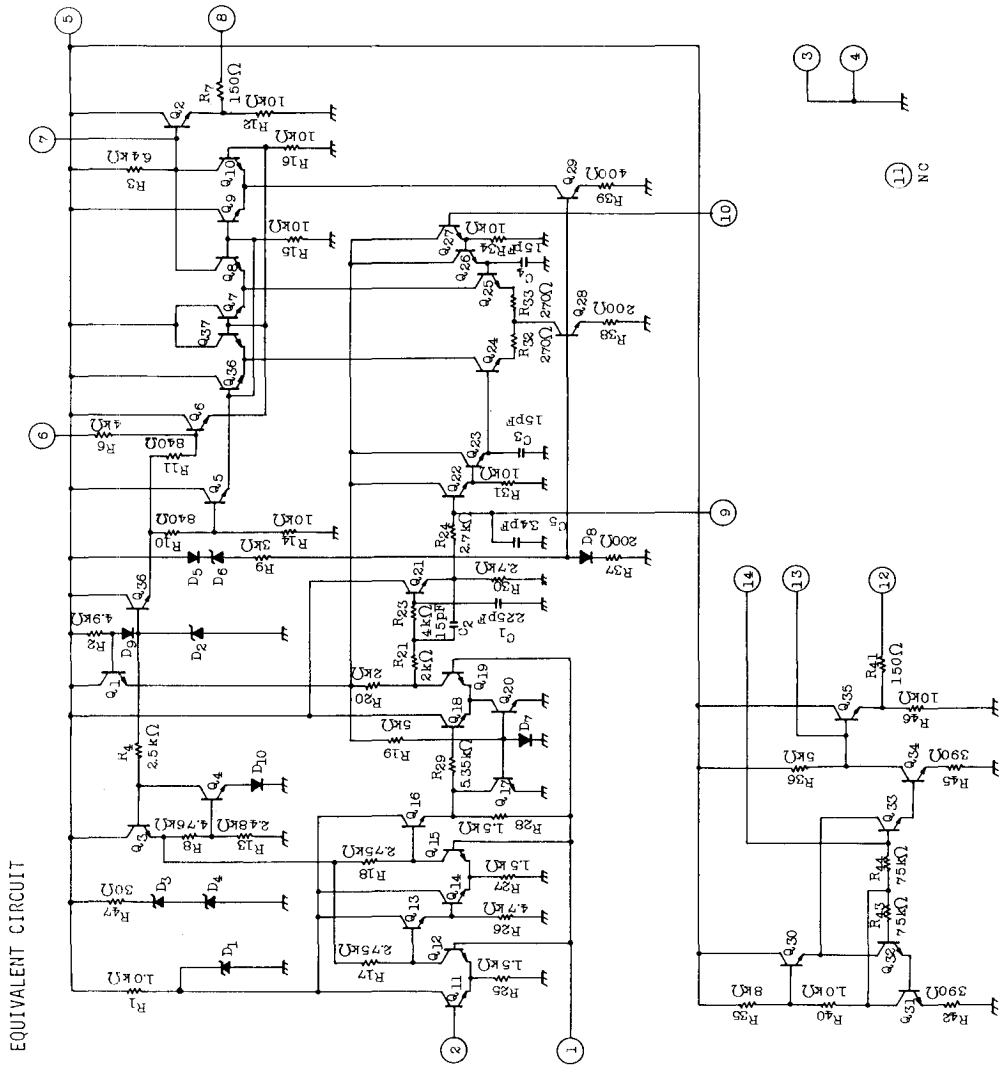

TEST CIRCUIT

1. $V_{IN(lim)}$, V_{OD} , AMR , $THD(1)$, ATT

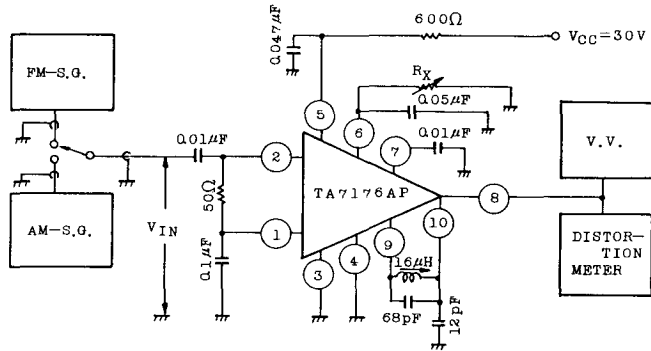

2. $G_V(AF)$, $THD(2)$, V_{OM}

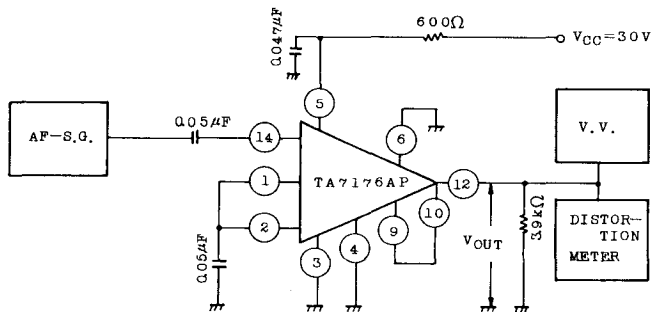

3. r_{ip} , c_{ip}

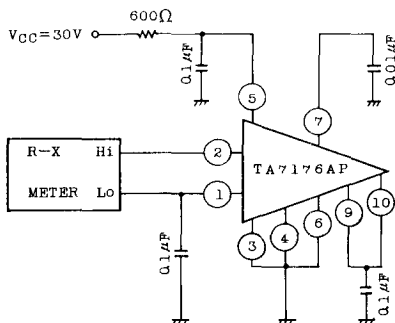

FREQUENCY RESPONSE (CHARACTERISTIC) OF IF AMPLIFIER SECTION

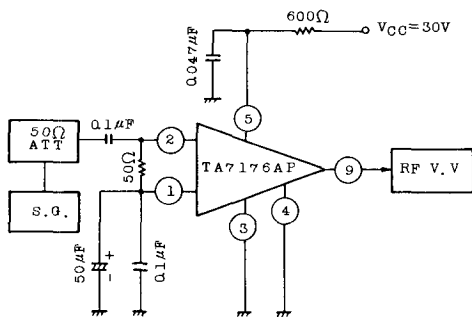
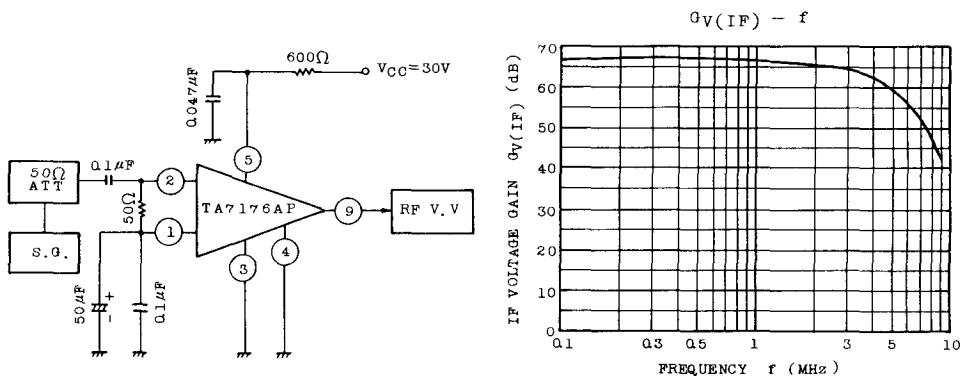



FREQUENCY RESPONSE (CHARACTERISTIC) OF AF AMPLIFIER SECTION

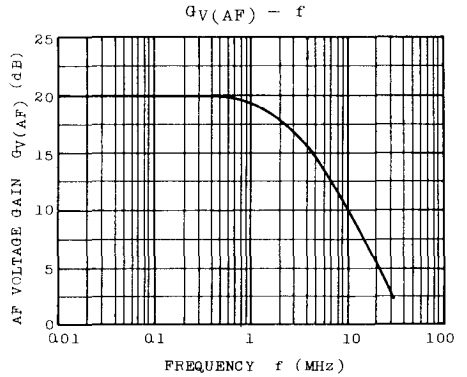
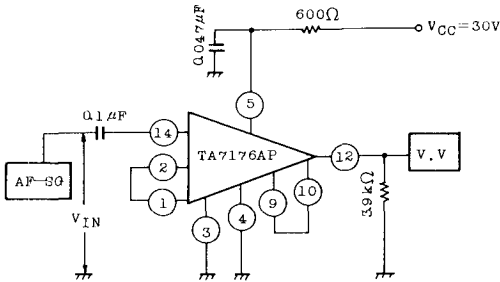

GAIN REDUCTION - EXTERNAL RESISTANCE CHARACTERISTICS

