



INTEGRATED CIRCUIT

TECHNICAL DATA

TA7200P

TOSHIBA BIPOLAR LINEAR INTEGRATED CIRCUIT
SILICON MONOLITHIC

3.3W AUDIO POWER AMPLIFIER
DESIGNED AS A AUDIO STAGE FOR STEREO,
TV, TAPE-PLAYER AND RADIO ETC.

- Output Power : $P_{OUT}=3.3W$ (Typ.)
at $V_{CC}=16V$, $R_L=8\Omega$, THD=5%
- Wide Operating Supply Voltage Range : $V_{CC}=10\sim 20V$
- Excellent Ripple Rejection
- 10-Lead Single in Line Plastic Package.

MAXIMUM RATINGS (Ta=25°C)

CHARACTERISTIC	SYMBOL	RATING	UNIT
Supply Voltage	V_{CC}	22	V
Output Peak Current	$I_O(\text{peak})$	1.2	A
Power Dissipation	P_D	4.5	W
Operating Temperature	T_{opr}	-20 ~ 75	°C
Storage Temperature	T_{stg}	-55 ~ 150	°C

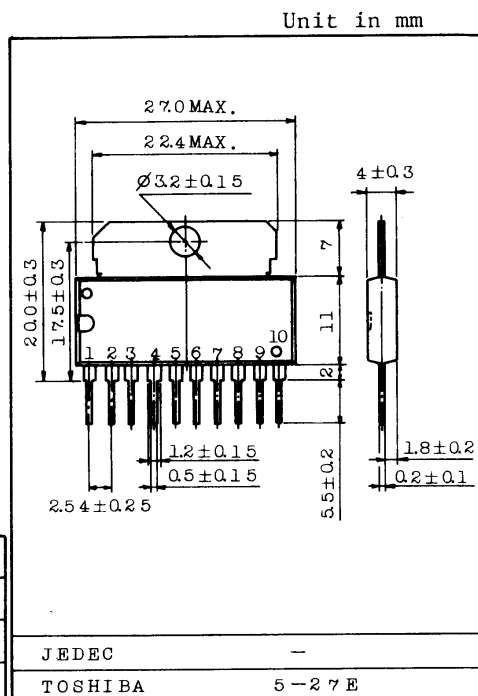

ELECTRICAL CHARACTERISTICS

(Unless otherwise specified $V_{CC}=16V$, $R_L=8\Omega$, $R_g=600\Omega$, $R_f=820\Omega$, $f=1kHz$, $T_a=25^\circ C$)

CHARACTERISTIC	SYMBOL	TEST CIR-CUIT	TEST CONDITION	MIN.	TYP.	MAX.	UNIT
Quiescent Current	I_{CCQ}	-	$V_{CC}=16V$	10	-	50	mA
			$V_{CC}=22V$	11	-	60	
Output Power	P_{OUT}	-	THD=5%	2.5	3.3	-	W
Total Harmonic Distortion	THD	-	$P_{OUT}=0.5W$	-	-	1.0	%
			$P_{OUT}=50mW$	-	-	1.5	
Voltage Gain	G_V	-	$R_f=0$, $C_f=33\mu F$, $V_{OUT}=2.45V_{rms}$	59	-	72	dB
			$R_f=820\Omega$, $V_{OUT}=2.45V_{rms}$	-	41	-	
Input Resistance	R_{IN}	-	$V_{OUT}=2V_{rms}$	-	70	-	k Ω
Output Noise Voltage	V_{NO}	-	$R_g=30k\Omega$, BW=50 ~ 20kHz	-	-	1.5	mV



INTEGRATED CIRCUIT

TA7200P

TECHNICAL DATA

EQUIVALENT CIRCUIT

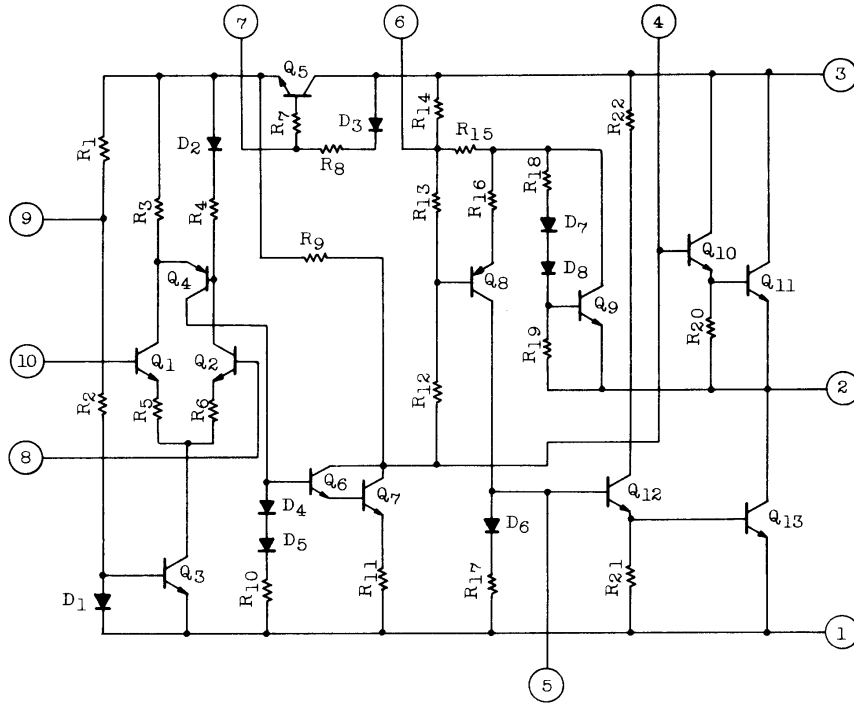

TEST AND APPLICATION CIRCUIT

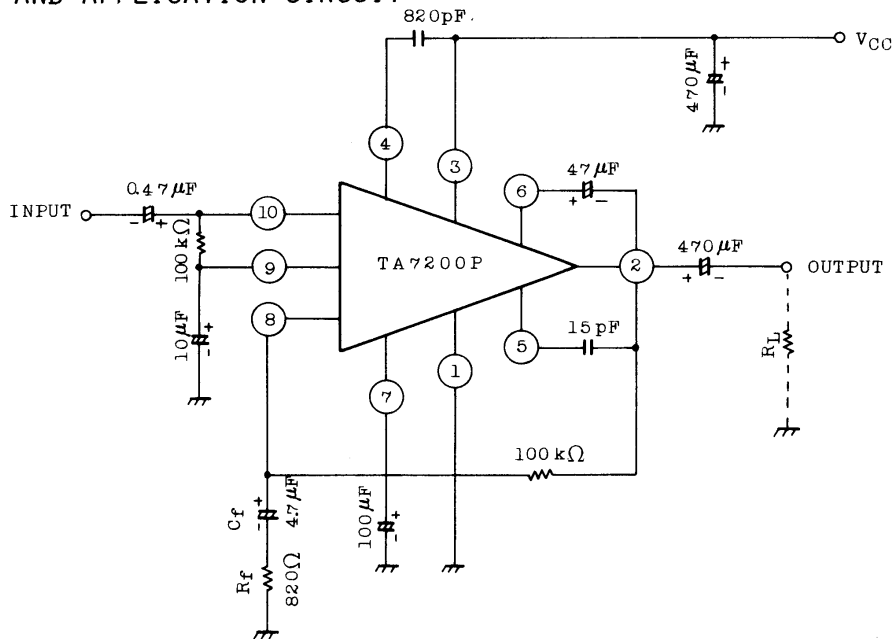



INTEGRATED CIRCUIT

TECHNICAL DATA

TA7200P

