

TA7268P

TENTATIVE

11W AUDIO POWER AMPLIFIER
DESIGNED AS A AUDIO OUTPUT STAGE FOR STEREO
TV AND HOME STEREO ETC.

- Output Power: $P_{OUT}=11W$ (Typ.)
at $V_{CC}=34V$, $R_L=8\Omega$, $THD=2\%$
- Low Distortion: $THD=0.03\%$ (Typ.)
at $P_{OUT}=2W$, $G_v=36dB$
- Wide Operating Supply Voltage Range:
 $V_{CC}=20 \sim 40V$
- Provided Thermal Shut-down Circuit and
Short Circuit Protection.
- Excellent Ripple Rejection.
- 12-Lead Single in Line Plastic Package.

MAXIMUM RATINGS ($T_a=25^\circ C$)

CHARACTERISTIC	SYMBOL	RATING	UNIT
Supply Voltage	V_{CC}	45	V
Output Current (Peak)	$I_{O(peak)}$	3.2	A
Power Dissipation	P_D	20	W
Operating Temperature	T_{opr}	$-20 \sim 75$	$^\circ C$
Storage Temperature	T_{stg}	$-55 \sim 150$	$^\circ C$

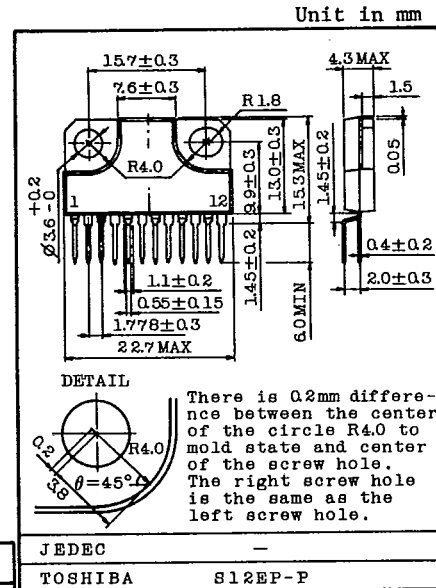

EQUIVALENT CIRCUIT

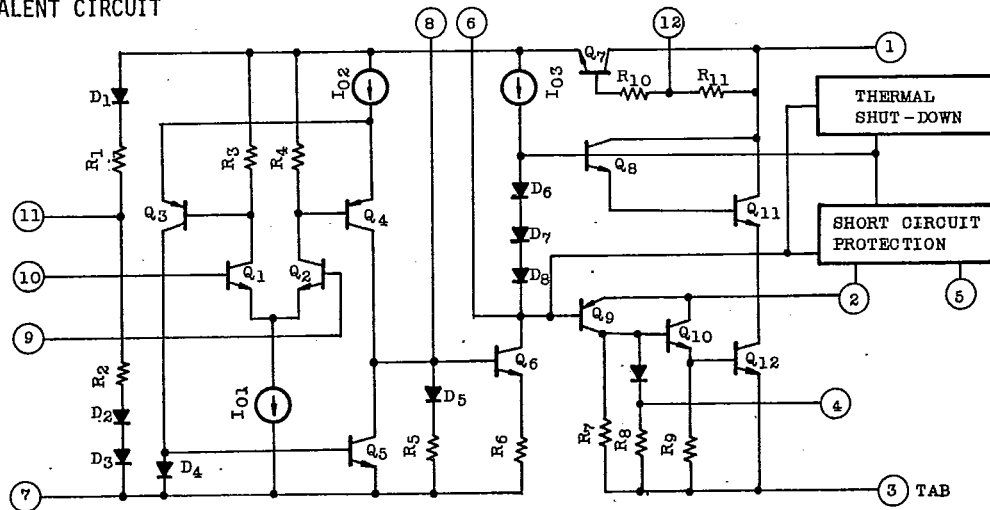

TA7268P

T-74-05-01

ELECTRICAL CHARACTERISTICS

(Unless otherwise specified, $V_{CC}=34V$, $R_L=8\Omega$, $R_g=600\Omega$, $R_f=1.5k\Omega$, $f=1kHz$, $T_a=25^\circ C$)

CHARACTERISTIC	SYMBOL	TEST CIR-CUIT	TEST CONDITION	MIN.	TYP.	MAX.	UNIT
Quiescent Current	I_{CCQ}	-	$V_{CC}=20V$	11	25	55	mA
			$V_{CC}=34V$	12	27	60	
			$V_{CC}=45V$	15	30	65	
Output Power	P_{OUT}	-	$f=70Hz \sim 30kHz$, THD=2%	-	11	-	W
Total Harmonic Distortion	THD	-	$P_{OUT}=10W$	-	0.7	2	%
			$P_{OUT}=2W$	-	0.03	0.15	
			$P_{OUT}=50mW$	-	0.05	0.4	
Voltage Gain	G_v	-	$R_f=0\Omega$, $C_4=100\mu F$, $V_{IN}=0.245mV_{rms}$	70	80	90	dB
			$R_f=1.5k\Omega$, $V_{IN}=10mV_{rms}$	-	36	-	
Input Resistance	R_{IN}	-	-	-	90	-	$k\Omega$
Output Noise Voltage	V_{NO}	-	$R_g=22k\Omega$, $BW=50Hz \sim 20kHz$	-	0.4	1.0	mV
Thermal Shut-down	T_{TSD}	-	Shut-down	-	145	-	$^\circ C$
			Reversion	-	100	-	

TEST AND APPLICATION CIRCUIT

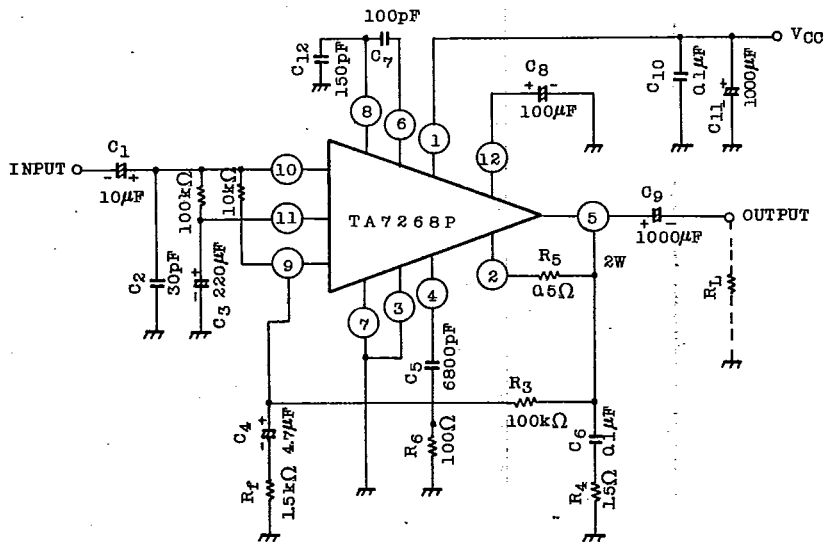

AUDIO LINEAR IC

TA7268P

(T-74-05-01

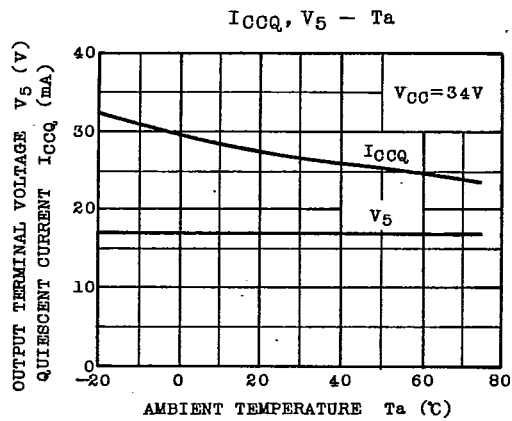
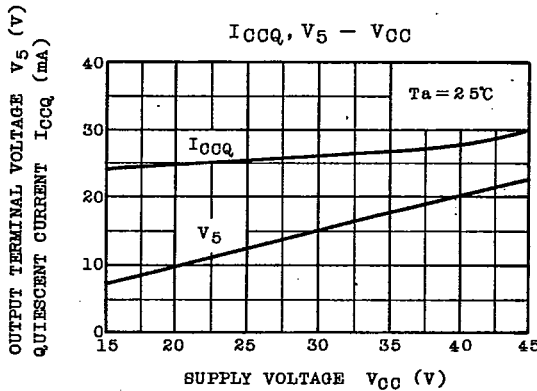
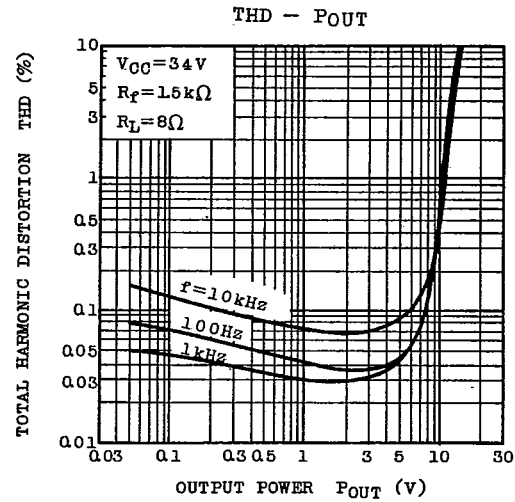
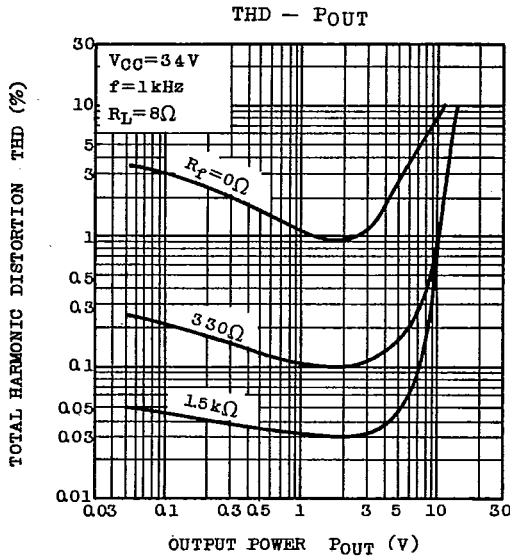
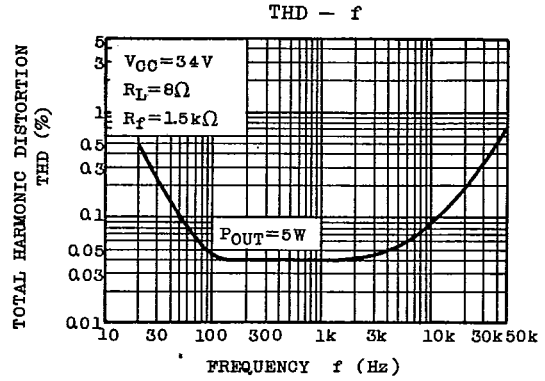
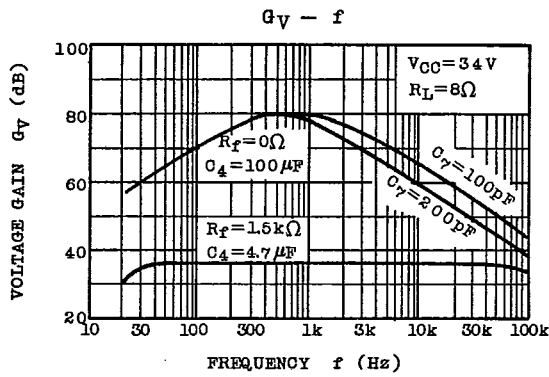

TA7268P

T-74-05-01

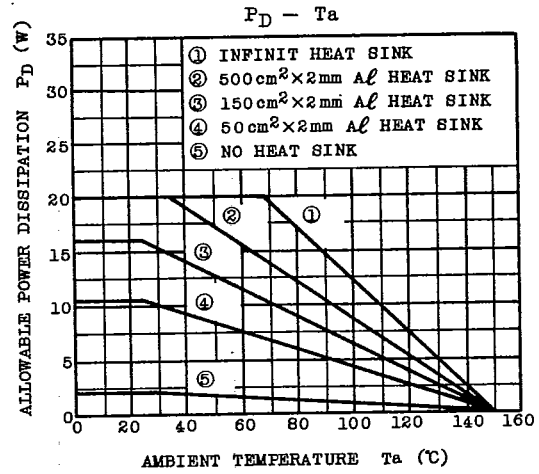
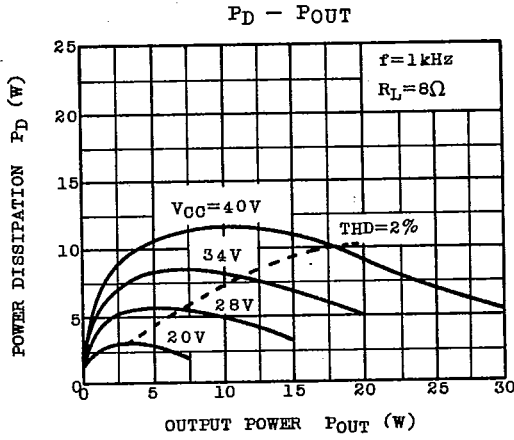

AUDIO LINEAR IC