



**HEWLETT  
PACKARD**

# HEXADECIMAL AND NUMERIC DISPLAYS FOR INDUSTRIAL APPLICATIONS

5082-7356  
5082-7357  
5082-7358  
5082-7359

## Features

- CERAMIC/GLASS PACKAGE
- ADDED RELIABILITY
- NUMERIC 5082-7356/-7357
  - 0-9, Test State, Minus Sign, Blank States, Decimal Point
  - 7356 Right Hand D.P., 7357 Left Hand D.P.
- HEXADECIMAL 5082-7359
  - 0-9, A-F, Base 16 Operation, Blanking Control, Conserves Power, No Decimal Point
- TTL COMPATIBLE
- INCLUDES DECODER/DRIVER WITH MEMORY
  - 8421 Positive Logic Input
- 4 x 7 DOT MATRIX ARRAY
  - Shaped Character, Excellent Readability
- STANDARD DUAL-IN-LINE PACKAGE
  - 15.2 mm x 10.2 mm (0.6 inch x 0.4 inch)
- CATEGORIZED FOR LUMINOUS INTENSITY

## Description

The HP 5082-735X series solid state numeric and hexadecimal displays with on-board decoder/driver and memory provide 7.4 mm (0.29 inch) displays for use in adverse industrial environments.

The 5082-7356 numeric display decodes positive 8421 BCD logic inputs into characters 0-9 "—" sign, a test pattern, and four blanks in the invalid BCD states. The unit employs a right-hand decimal point.

## Package Dimensions

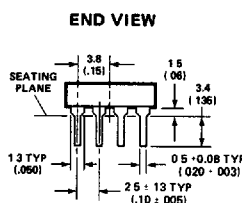
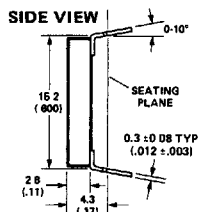
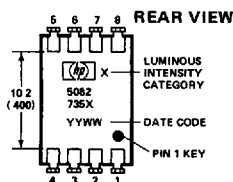
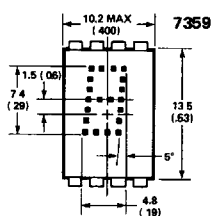
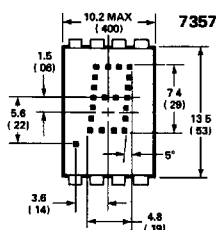
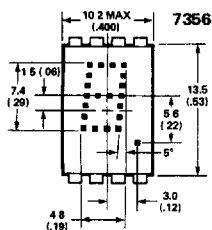

PIN	FUNCTION	
	5082-7356 AND 7357 NUMERIC	5082-7359 HEXA-DECIMAL
1	Input 2	Input 2
2	Input 4	Input 4
3	Input 8	Input 8
4	Decimal point	Blanking control
5	Latch enable	Latch enable
6	Ground	Ground
7	V <sub>CC</sub>	V <sub>CC</sub>
8	Input 1	Input 1

### NOTES:

1. Dimensions in millimeters and (inches).
2. Unless otherwise specified, the tolerance on all dimensions is  $\pm 0.25\text{mm}$  ( $\pm 0.010$  in.).
3. Digit center line is  $\pm 0.25\text{mm}$  ( $\pm 0.010$  in) from package center line.

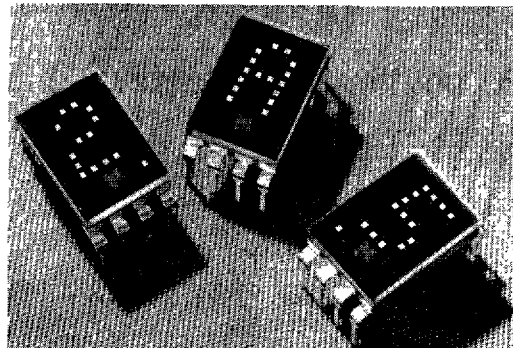

The 5082-7357 is the same as the 5082-7356, except that the decimal point is located on the left-hand side of the digit.

The 5082-7359 hexadecimal display decodes positive 8421 logic inputs into 16 states, 0-9 and A-F. In place of the decimal point an input is provided for blanking the display (all LED's off), without losing the contents of the memory. Applications include terminals and computer systems using the base-16 character set.

The 5082-7358 is a ( $\pm 1$ ) overrange display including a right-hand decimal point.

## Applications

Typical applications include control systems, instrumentation, communication systems, and transportation equipment.

ALPHANUMERIC  
DISPLAYS

## Absolute Maximum Ratings

Description	Symbol	Min.	Max.	Unit
Storage temperature, ambient	$T_S$	-65	+125	°C
Operating temperature, ambient <sup>(1,2)</sup>	$T_A$	-55	+100	°C
Supply voltage <sup>(3)</sup>	$V_{CC}$	-0.5	+7.0	V
Voltage applied to input logic, dp and enable pins	$V_I, V_{DP}, V_E$	-0.5	+7.0	V
Voltage applied to blanking input <sup>(7)</sup>	$V_B$	-0.5	$V_{CC}$	V
Maximum solder temperature at 1.59mm (.062 inch) below seating plane; $t \leq 5$ seconds			260	°C

## Recommended Operating Conditions

Description	Symbol	Min.	Nom.	Max.	Unit
Supply Voltage	$V_{CC}$	4.5	5.0	5.5	V
Operating temperature, ambient	$T_A$	-55		+85	°C
Enable Pulse Width	$t_w$	100			nsec
Time data must be held before positive transition of enable line	$t_{SETUP}$	50			nsec
Time data must be held after positive transition of enable line	$t_{HOLD}$	50			nsec
Enable pulse rise time	$t_{TLH}$			200	nsec

## Electrical/Optical Characteristics $(T_A = -55^\circ\text{C}$ to $+85^\circ\text{C}$ , Unless Otherwise Specified)

Description	Symbol	Test Conditions	Min.	Typ. <sup>(4)</sup>	Max.	Unit
Supply Current	$I_{CC}$	$V_{CC} = 5.5\text{ V}$ (characters "5" or "B" displayed)		112	170	mA
Power dissipation	$P_T$			560	935	mW
Luminous intensity per LED (Digit average) <sup>(5,6)</sup>	$I_v$	$V_{CC} = 5.0\text{ V}$ , $T_A = 25^\circ\text{C}$	40	85		$\mu\text{cd}$
Logic low-level input voltage	$V_{IL}$	$V_{CC} = 4.5\text{ V}$			0.8	V
Logic high-level input voltage	$V_{IH}$		2.0			V
Enable low-voltage; data being entered	$V_{EL}$				0.8	V
Enable high-voltage; data not being entered	$V_{EH}$		2.0			V
Blanking low-voltage; display not blanked <sup>(7)</sup>	$V_{BL}$				0.8	V
Blanking high-voltage; display blanked <sup>(7)</sup>	$V_{BH}$		3.5			V
Blanking low-level input current <sup>(7)</sup>	$I_{BL}$		$V_{CC} = 5.5\text{ V}$ , $V_{BL} = 0.8\text{ V}$			50
Blanking high-level input current <sup>(7)</sup>	$I_{BH}$	$V_{CC} = 5.5\text{ V}$ , $V_{BH} = 4.5\text{ V}$			1.0	mA
Logic low-level input current	$I_{IL}$	$V_{CC} = 5.5\text{ V}$ , $V_{IL} = 0.4\text{ V}$			-1.6	mA
Logic high-level input current	$I_{IH}$	$V_{CC} = 5.5\text{ V}$ , $V_{IH} = 2.4\text{ V}$			+100	$\mu\text{A}$
Enable low-level input current	$I_{EL}$	$V_{CC} = 5.5\text{ V}$ , $V_{EL} = 0.4\text{ V}$			-1.6	mA
Enable high-level input current	$I_{EH}$	$V_{CC} = 5.5\text{ V}$ , $V_{EH} = 2.4\text{ V}$			+130	$\mu\text{A}$
Peak wavelength	$\lambda_{PEAK}$	$T_A = 25^\circ\text{C}$		655		nm
Dominant Wavelength <sup>(8)</sup>	$\lambda_d$	$T_A = 25^\circ\text{C}$		640		nm
Weight				1.0		gm

Notes: 1. Nominal thermal resistance of a display mounted in a socket which is soldered into a printed circuit board:  $\theta_{JA} = 50^\circ\text{C/W}$ ;  $\theta_{JC} = 15^\circ\text{C/W}$ ; 2.  $\theta_{CA}$  of a mounted display should not exceed  $35^\circ\text{C/W}$  for operation up to  $T_A = +100^\circ\text{C}$ . 3. Voltage values are with respect to device ground, pin 6. 4. All typical values at  $V_{CC} = 5.0$  Volts,  $T_A = 25^\circ\text{C}$ . 5. These displays are categorized for luminous intensity with the intensity category designated by a letter located on the back of the display contiguous with the Hewlett-Packard logo marking. 6. The luminous intensity at a specific ambient temperature,  $I_v(T_A)$ , may be calculated from this relationship:  $I_v(T_A) = I_v(25^\circ\text{C}) \cdot (.985)^{|T_A - 25^\circ\text{C}|}$ . 7. Applies only to 7359. 8. The dominant wavelength,  $\lambda_d$ , is derived from the CIE chromaticity diagram and represents the single wavelength which defines the color of the device.

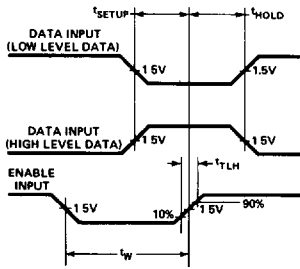

Figure 1. Timing Diagram of 5082-735X Series Logic.

				TRUTH TABLE	
BCD DATA <sup>[1]</sup>				5082 7356/7357	5082 7359
X <sub>8</sub>	X <sub>4</sub>	X <sub>2</sub>	X <sub>1</sub>		
L	L	L	L	.	.
L	L	L	H	.	.
L	L	H	L	.	.
L	L	H	H	.	.
L	H	L	L	.	.
L	H	L	H	.	.
L	H	H	L	.	.
L	H	H	H	.	.
H	L	L	L	.	.
H	L	L	H	.	.
H	L	H	L	(BLANK)	.
H	L	H	H	(BLANK)	.
H	H	L	L	(BLANK)	.
H	H	L	H	(BLANK)	.
H	H	H	L	(BLANK)	.
H	H	H	H	(BLANK)	.
DECIMAL PT <sup>[2]</sup>				ON	V <sub>DP</sub> = L
				OFF	V <sub>DP</sub> = H
ENABLE <sup>[1]</sup>				LOAD DATA	V <sub>E</sub> = L
				LATCH DATA	V <sub>E</sub> = H
BLANKING <sup>[3]</sup>				DISPLAY ON	V <sub>B</sub> = L
				DISPLAY OFF	V <sub>B</sub> = H

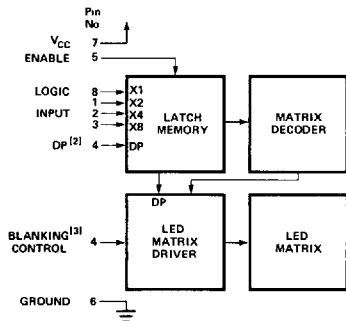

Figure 2. Block Diagram of 5082-735X Series Logic.

Notes

- H = Logic High; L = Logic Low. With the enable input at logic high changes in BCD input logic levels or D.P. input have no effect upon display memory, displayed character, or D.P.
- The decimal point input, DP, pertains only to the 5082-7356 and 5082-7357 displays.
- The blanking control input, B, pertains only to the 5082-7359 hexadecimal display. Blanking input has no effect upon display memory.

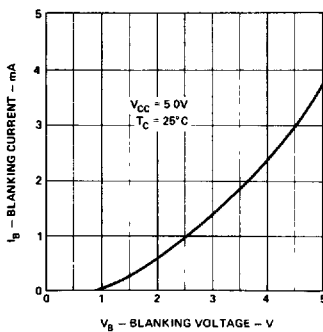

Figure 3. Typical Blanking Control Current vs. Voltage for 5082-7359.

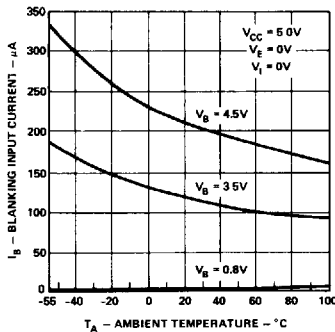

Figure 4. Typical Blanking Control Input Current vs. Ambient Temperature for 5082-7359.

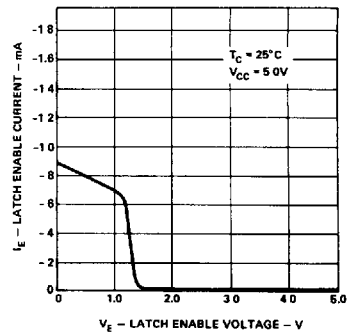

Figure 5. Typical Latch Enable Input Current vs. Voltage.

ALPHANUMERIC DISPLAYS

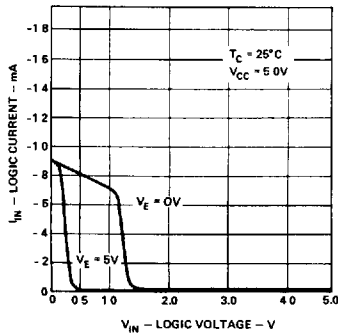

Figure 6. Typical Logic and Decimal Point Input Current vs. Voltage.

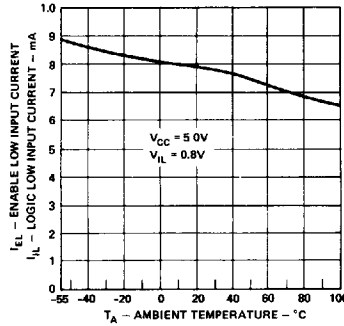

Figure 7. Typical Logic and Enable Low Input Current vs. Ambient Temperature.

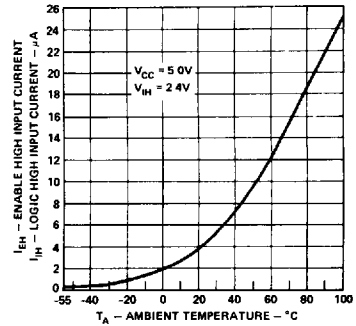

Figure 8. Typical Logic and Enable High Input Current vs. Ambient Temperature.

## Operational Considerations

### ELECTRICAL

The 5082-735X series devices use a modified 4 x 7 dot matrix of light emitting diodes (LED's) to display decimal/hexadecimal numeric information. The LED's are driven by constant current drivers. BCD information is accepted by the display memory when the enable line is at logic low and the data is latched when the enable is at logic high. To avoid the latching of erroneous information, the enable pulse rise time should not exceed 200 nanoseconds. Using the enable pulse width and data setup and hold times listed in the Recommended Operating Conditions allows data to be clocked into an array of displays at a 6.7MHz rate.

The blanking control input on the 5082-7395 display blanks (turns off) the displayed hexadecimal information without disturbing the contents of display memory. The display is blanked at a minimum threshold level of 3.5 volts. This may be easily achieved by using an open collector TTL gate and a pull-up resistor. For example, (1/6) 7416 hexinverter buffer/driver and a 120 ohm pull-up resistor will provide sufficient drive to blank eight displays. The size of the blanking pull-up resistor may be calculated from the following formula, where N is the number of digits:

$$R_{\text{blank}} = (V_{\text{CC}} - 3.5V) / [N (1.0mA)]$$

The decimal point input is active low true and this data is latched into the display memory in the same fashion as is the BCD data. The decimal point LED is driven by the on-board IC.

The ESD susceptibility of these IC devices is Class A of MIL-STD-883 or Class 2 of DOD-STD-1686 and DOD-HDBK-263.

### MECHANICAL

These displays are designed for use in adverse industrial environments.

These displays may be mounted by soldering directly to a printed circuit board or inserted into a socket. The lead-to-lead pin spacing is 2.54mm (0.100 inch) and the lead row spacing is 15.24mm (0.600 inch). These displays may be end stacked with 2.54mm (0.100 inch) spacing between outside pins of adjacent displays. Sockets such as Augat 324-AG2D (3 digits) or Augat 508-AG8D (one digit, right angle mounting) may be used.

The primary thermal path for power dissipation is through the device leads. Therefore, to insure reliable operation up to an ambient temperature of +100°C, it is important to maintain a case-to-ambient thermal resistance of less than 35°C/watt as measured on top of display pin 3.

Post solder cleaning may be accomplished using water, Freon/alcohol mixtures formulated for vapor cleaning processing (up to 2 minutes in vapors at boiling) or Freon/alcohol mixtures formulated for room temperature cleaning. Suggested solvents: Freon TF, Freon TE, Genesolv DI-15, Genesolv DE-15.

### CONTRAST ENHANCEMENT

The 5082-735X displays have been designed to provide the maximum possible ON/OFF contrast when placed behind an appropriate contrast enhancement filter. Some suggested filters are Panelgraphic Ruby Red 60 and Dark Red 63, SGL Homalite H100-1605, 3M Light Control Film and Polaroid HRCF Red Circular Polarizing Filter. For further information see Hewlett-Packard Application Note 964.

# Solid State Over Range Display

For display applications requiring a ±, 1, or decimal point designation, the 5082-7358 over range display is available. This display module comes in the same package as the 5082-735X series numeric display and is completely compatible with it.

## Package Dimensions

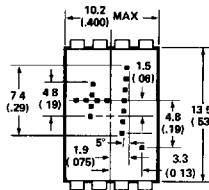

FRONT

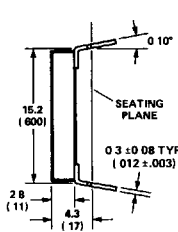

SIDE

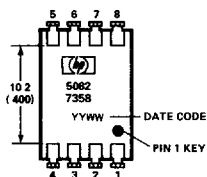

REAR

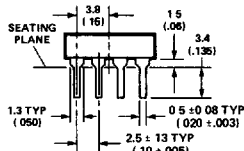

END

NOTES  
 1 DIMENSIONS IN MILLIMETERS AND (INCHES)  
 2 UNLESS OTHERWISE SPECIFIED, THE TOLERANCE ON ALL DIMENSIONS IS ± 0.38 MM (± 0.015 INCHES).

PIN	FUNCTION
1	Plus
2	Numeral One
3	Numeral One
4	DP
5	Open
6	Open
7	V <sub>CC</sub>
8	Minus/Plus

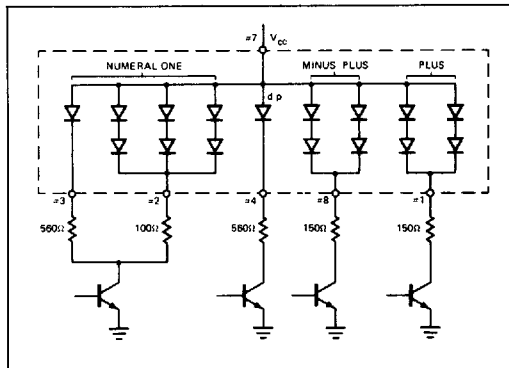

Figure 9. Typical Driving Circuit.

### TRUTH TABLE

CHARACTER	PIN			
	1	2,3	4	8
+	H	X	X	H
-	L	X	X	H
1	X	H	X	X
Decimal Point	X	X	H	X
Blank	L	L	L	L

NOTES: L: Line switching transistor in Figure 9 cutoff.  
 H: Line switching transistor in Figure 9 saturated.  
 X: 'Don't care'

## Electrical/Optical Characteristics

5082-7358 (T<sub>A</sub> = -55°C to +85°C, Unless Otherwise Specified)

DESCRIPTION	SYMBOL	TEST CONDITIONS	MIN	TYP	MAX	UNIT
Forward Voltage per LED	V <sub>F</sub>	I <sub>F</sub> = 10 mA		1.6	2.0	V
Power dissipation	P <sub>T</sub>	I <sub>F</sub> = 10 mA all diodes lit		280	320	mW
Luminous Intensity per LED (digit average)	I <sub>v</sub>	I <sub>F</sub> = 6 mA T <sub>C</sub> = 25°C	40	85		μcd
Peak wavelength	λ <sub>peak</sub>	T <sub>C</sub> = 25°C		655		nm
Dominant Wavelength	λ <sub>d</sub>	T <sub>C</sub> = 25°C		640		nm
Weight				1.0		gm

## Recommended Operating Conditions

	SYMBOL	MIN	NOM	MAX	UNIT
LED supply voltage	V <sub>CC</sub>	4.5	5.0	5.5	V
Forward current, each LED	I <sub>F</sub>		5.0	10	mA

NOTE:  
 LED current must be externally limited. Refer to Figure 9 for recommended resistor values.

## Absolute Maximum Ratings



DESCRIPTION	SYMBOL	MIN.	MAX.	UNIT
Storage temperature, ambient	T <sub>S</sub>	-65	+125	°C
Operating temperature, ambient	T <sub>A</sub>	-55	+100	°C
Forward current, each LED	I <sub>F</sub>		10	mA
Reverse voltage, each LED	V <sub>R</sub>		4	V

ALPHANUMERIC DISPLAYS

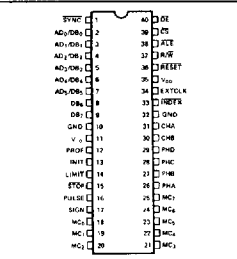
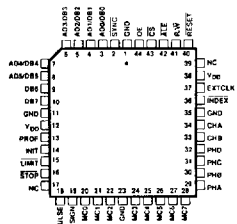
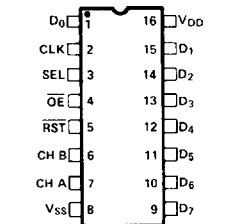
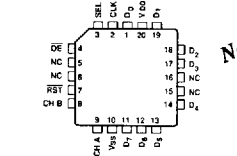
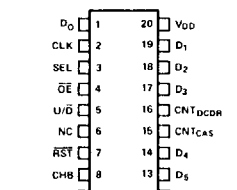
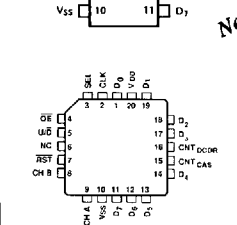
Motion Control ICS – HCTL-XXXX Series

Package Outline Drawing	Part No.	Package	Description	Page No.
	HCTL-1100	PDIP	CMOS General Purpose Motion Control IC	1-104
	HCTL-1100 OPT PLC	PLCC	CMOS General Purpose Motion Control IC	1
	HCTL-2000	PDIP	CMOS Quadrature Decoder/Counter IC, 12-bit Counter	1-86
	HCTL-2016	PDIP	CMOS Quadrature Decoder/Counter IC, 16-bit Counter	
	<b>New</b> HCTL-2016 OPT PLC	PLCC	CMOS Quadrature Decoder/Counter IC, 16-bit Counter	1-102
	HCTL-2020	PDIP	CMOS Quadrature Decoder/Counter IC, 16-bit Counter, Quadrature Decoder Output Signals, Cascade Output Signals	1-86
	<b>New</b> HCTL-2020 OPT PLC	PLCC	CMOS Quadrature Decoder/Counter IC, 16-bit Counter, Quadrature Decoder Output Signals, Cascade Output Signals	1-102

## Accessories for Encoders and Encoder Modules

Package Outline Drawing	Part No.	Description	Page No.
	HEDS-8902	4-wire connector with 15.5 cm (6.1 in.) flying leads. Locks into HEDS-5500 and HEDS-5600 2 channel encoders. Also fits HEDS-9000, HEDS-9100, and HEDS-9200 2 channel encoder modules.	1-61 1-22 1-28
	HEDS-8903	5-wire connector with 15.5 cm (6.1 in.) flying leads. Locks into HEDS-5540 and HEDS-5640 three channel encoders. Also fits HEDS-9040 and HEDS-9140 three channel encoder modules.	1-61 1-32
	HEDS-8905	Alignment Tool for HEDS-9140	1-32
	HEDS-8906	Alignment Tool for HEDS-9040	1-32
	HEDS-8901	Gap Setting shown for film codewheels	1-51
	HEDS-8932	Gap Setting shown for glass codewheels	1-51
	HEDS-8910 OPT 0 □□	Alignment Tool for HEDS-5540/5545 and HEDS-5640/5645. Order in appropriate shaft size.	1-61