



SAURO[®]
ELECTRONIC CONNECTORS
by the law

MSM

Terminal Blocks

MSM

Functional characteristics



Dimensional class:
medium



Standard colour:
green



Height:
15.2 mm (.598 in)



Max approved wire sections:
solid: 2.5 mm² (VDE); 12 AWG (UL)
stranded: 2.5 mm² (VDE); 12 AWG (UL)

Clamp opening size:
2.5 x 2.3 mm (.098 x .087 in)



Versions:
modular

Single mould poles:
from 2 to 25



Pitches:
metric 5 mm, 7.5 mm, 10 mm
(.197 in, .295 in, .394 in)



imperial 5.08 mm, 7.62 mm, 10.16 mm
(.200 in, .300 in, .400 in)

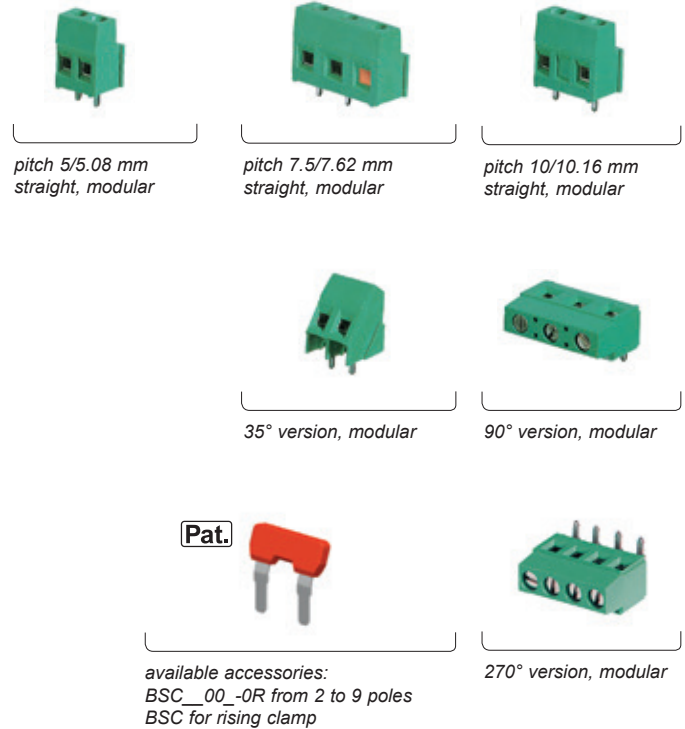
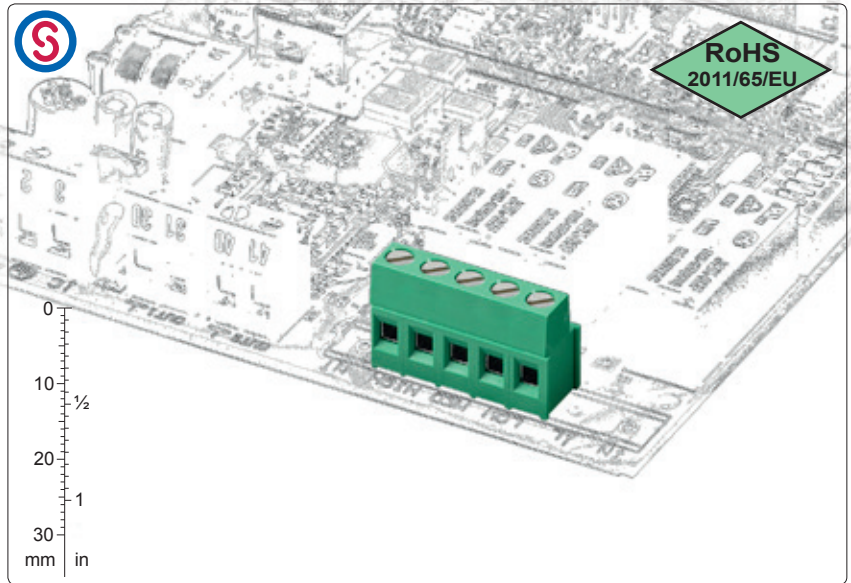

Brief description

With the **MSM** modular series terminal blocks for PCBs, wires up to 2.5 mm² (12 AWG) can be used and consequently a current range of 24A certified can be reached.

It is available in 5 mm (.197 in), 7.5 mm (.294 in) and 10 mm (.394 in) metric pitches, and in 5.08 mm (.200 in), 7.62 mm (.300 in) and 10.16 mm (.400 in) Imperial pitches, in monolithic blocks from 2 to 25 poles, with insertion of the wire parallel, inclined at 45° or vertical in relation to the PCB.

All the housings are modular, therefore it is possible to compose the monolithic terminal blocks from 2 to 25 poles separately, or to

compose the basic terminal blocks until any number of poles is obtained. By taking advantage of this particular characteristic a minimum stock of basic terminal blocks can be kept.

It is simple to manage the product, the warehouse and the assembly with the Kit packages because several versions can be received with only one code, the part-numbers are significantly reduced and the risk of making mistakes is also reduced.

Components features

- M3 nickel plated copper alloy screw.
- Polyamide housing.
Standard colour: GREEN.
V0 self-extinguishing according to UL 94.
Chlorinated solvents resistant,
with no phosphor, dioxin or
detrimental to health halogens.
- Nickel plated copper alloy clamp
- Easy to solder lead-free
tin-plated copper alloy pin.

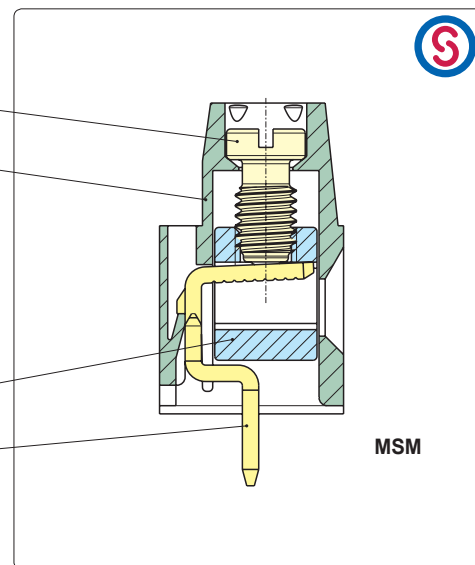

Mechanical features

Recommended/highest tightening torque	0.5/0.6 Nm (4.42/5.31 lbf-in)
PCB thickness:	max. 2.4 mm (.094 in)
PCB hole diameter:	min. 1.4 mm (.055 in)
Stripping length	5.5 ÷ 6.5 mm (.22 ÷ .26 in)
Operating temperature range	-40 °C ÷ +110 °C (-40 °F ÷ +230 °F)
Climatic category	40/110/21 according to EN 60068-1

Electric features*

Solid wire section	30÷12 AWG (UL)* 0.05÷2.5 mm ² (VDE)*
Stranded wire section	30÷12 AWG (UL)* 0.05÷2.5 mm ² (VDE)*
Rated voltage for 5 mm (.197 in) and 5.08 mm (.200 in)	300 V (UL)*
Rated voltage for 7.5 mm (.295 in) and 7.62 mm (.300 in)	750 V (IMQ)*
Rated voltage for 10 mm (.394 in) and 10.16 mm (.400 in)	750 V (IMQ)*
Rated current	24 A (VDE)*
Contact resistance	<15 mΩ
Insulation resistance	>10 ⁹ Ω (500V DC)

*All the above mentioned data refer to the highest values amongst the certificated ones.
V voltage, I current values and tightening torque are related to the norms to be applied to the product and to its use.

Approvals

IEC-EN	IEC:	250 V - 24 A - 2.5 mm ² - T 110 for 5 mm and 5.08 mm pitch
	EN 60998	750 V - 24 A - 2.5 mm ² - T 110 for 7.5 mm, 7.62 mm, 10 mm and 10.16 mm pitch
UL	UL:	300 V - 17.5 A - 30÷12 AWG - 7 lbf-in for 5 mm, 5.08 mm, 7.5 mm and 7.62 mm pitch
	File E167473	600 V - 17.5 A - 30÷12 AWG - 7 lbf-in for 10 mm and 10.16 mm pitch
		Application values for end-use equipment have to be in accordance to UL norms and applicable to it.
VDE	VDE:	250 V - 24 A - T 110 - 2.5 mm ² for 5 mm and 5.08 mm pitch
	Reg. n. 40022741	450 V - 24 A - T 110 - 2.5 mm ² for 7.5 mm and 7.62 mm pitch
		750 V - 24 A - T 110 - 2.5 mm ² for 10 mm and 10.16 mm pitch
IMQ	IMQ:	250 V - 24 A - 2.5 mm ² - T 110 for 5 mm and 5.08 mm pitch
	File: EA022	750 V - 24 A - 2.5 mm ² - T 110 for 7.5 mm, 7.62 mm, 10 mm and 10.16 mm pitch
CSA	CSA:	300 V - 17.5 A - 30÷12 AWG for 5 mm, 5.08 mm, 7.5 mm and 7.62 mm pitch
	File LR102896	600 V - 17.5 A - 30÷12 AWG for 10 mm and 10.16 mm pitch

See also "Certifications", page 8

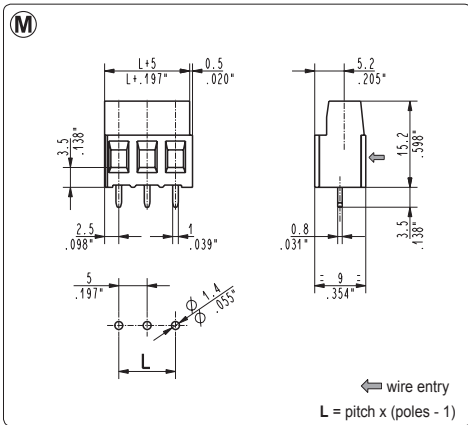

MSM_001 straight, modular

5 mm / .197" pitch

Poles	Code	Pcs/pack.	W [kg]*	Pcs/Ind.**	W [kg]*
02	MSM02001	900	2,70	2000	6,00
03	MSM03001	600	2,70	1750	7,88
04	MSM04001	400	2,40	1500	9,00
05	MSM05001	350	2,63	1000	7,50
06	MSM06001	300	2,70	750	6,75
07	MSM07001	250	2,63	750	7,88
08	MSM08001	200	2,40	750	9,00
09	MSM09001	175	2,36	500	6,75
10	MSM10001	175	2,63	500	7,50
11	MSM11001	150	2,48	500	8,25
12	MSM12001	150	2,70	500	9,00
13	MSM13001	75	1,46	500	9,75
14	MSM14001	75	1,58	250	5,25
15	MSM15001	75	1,69	250	5,63
16	MSM16001	75	1,80	250	6,00
17	MSM17001	75	1,91	250	6,38
18	MSM18001	75	2,03	250	6,75
19	MSM19001	50	1,43	250	7,13
20	MSM20001	50	1,50	250	7,50
21	MSM21001	50	1,58	250	7,88
22	MSM22001	50	1,65	250	8,25
23	MSM23001	50	1,73	250	8,63
24	MSM24001	50	1,80	250	9,00
25	MSM25001	50	1,88	250	9,38

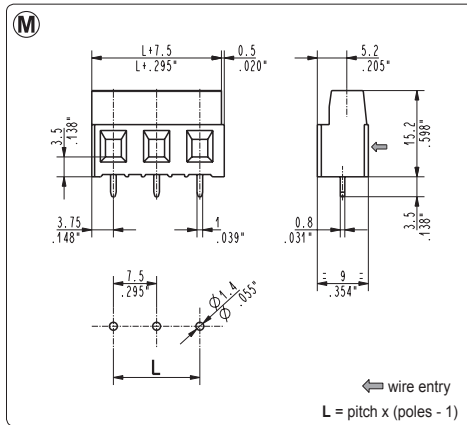

MSM_003 straight, modular

7.5 mm / .295" pitch

Poles	Code	Pcs/pack.	W [kg]*	Pcs/Ind.**	W [kg]*
02	MSM02003	300	1,05	1750	6,13
03	MSM03003	200	1,05	1500	7,88
04	MSM04003	150	1,05	1250	8,75

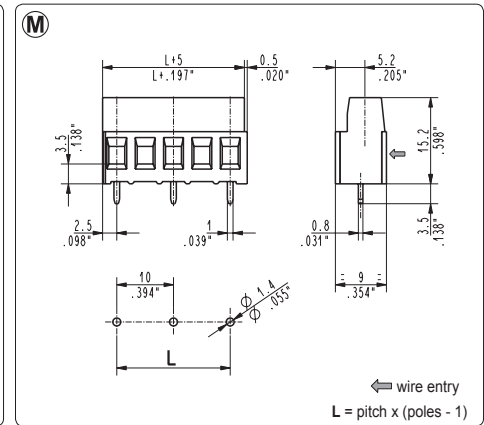

MSM_002 straight, modular

10 mm / .394" pitch

Poles	Code	Pcs/pack.	W [kg]*	Pcs/Ind.**	W [kg]*
01	MSM01002	450	0,80	2000	3,54
02	MSM02002	300	1,06	1750	6,20
03	MSM03002	175	0,93	1000	5,31
04	MSM04002	125	0,89	750	5,31
05	MSM05002	100	0,89	500	4,43
06	MSM06002	75	0,80	500	5,31
07	MSM07002	75	0,93	500	6,20
08	MSM08002	75	1,06	500	7,08
09	MSM09002	75	1,19	250	3,98
10	MSM10002	50	0,89	250	4,43
11	MSM11002	50	0,97	250	4,87
12	MSM12002	50	1,06	250	5,31
13	MSM13002	50	1,15	250	5,75

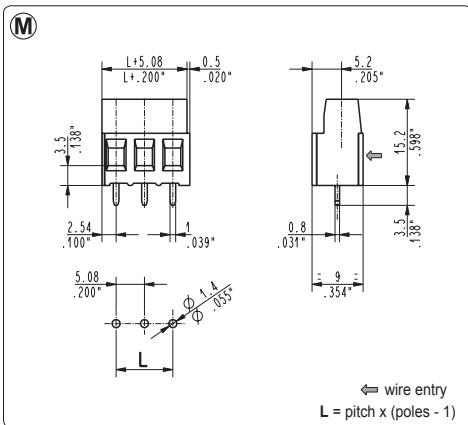

MSM_005 straight, modular

5.08 mm / .200" pitch

Poles	Code	Pcs/pack.	W [kg]*	Pcs/Ind.**	W [kg]*
02	MSM02005	900	2,70	2000	6,00
03	MSM03005	600	2,70	1750	7,88
04	MSM04005	400	2,40	1500	9,00
05	MSM05005	350	2,63	1000	7,50
06	MSM06005	300	2,70	750	6,75
07	MSM07005	250	2,63	750	7,88
08	MSM08005	200	2,40	750	9,00
09	MSM09005	175	2,36	500	6,75
10	MSM10005	175	2,63	500	7,50
11	MSM11005	150	2,48	500	8,25
12	MSM12005	150	2,70	500	9,00
13	MSM13005	75	1,46	500	9,75
14	MSM14005	75	1,58	250	5,25
15	MSM15005	75	1,69	250	5,63
16	MSM16005	75	1,80	250	6,00
17	MSM17005	75	1,91	250	6,38
18	MSM18005	75	2,03	250	6,75
19	MSM19005	50	1,43	250	7,13
20	MSM20005	50	1,50	250	7,50
21	MSM21005	50	1,58	250	7,88
22	MSM22005	50	1,65	250	8,25
23	MSM23005	50	1,73	250	8,63
24	MSM24005	50	1,80	250	9,00
25	MSM25005	50	1,88	250	9,38

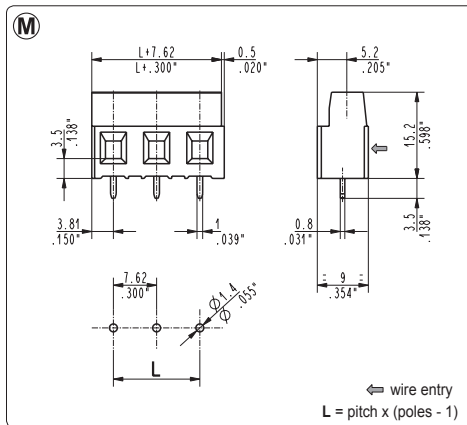

MSM_007 straight, modular

7.62 mm / .300" pitch

Poles	Code	Pcs/pack.	W [kg]*	Pcs/Ind.**	W [kg]*
02	MSM02007	300	1,05	1750	6,13
03	MSM03007	200	1,05	1500	7,88

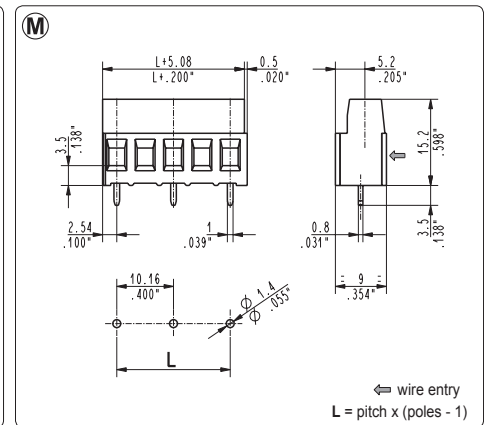

MSM_006 straight, modular

10.16 mm / .400" pitch

Poles	Code	Pcs/pack.	W [kg]*	Pcs/Ind.**	W [kg]*
01	MSM01006	450	0,80	2000	3,54
02	MSM02006	300	1,06	1750	6,20
03	MSM03006	175	0,93	1000	5,31
04	MSM04006	125	0,89	750	5,31
05	MSM05006	100	0,89	500	4,43
06	MSM06006	75	0,80	500	5,31
07	MSM07006	75	0,93	500	6,20
08	MSM08006	75	1,06	500	7,08
09	MSM09006	75	1,19	250	3,98
10	MSM10006	50	0,89	250	4,43
11	MSM11006	50	0,97	250	4,87
12	MSM12006	50	1,06	250	5,31
13	MSM13006	50	1,15	250	5,75

*W [kg]: approximate weight per box in kg

**Industrial packaging: add "-00000E" at standard code

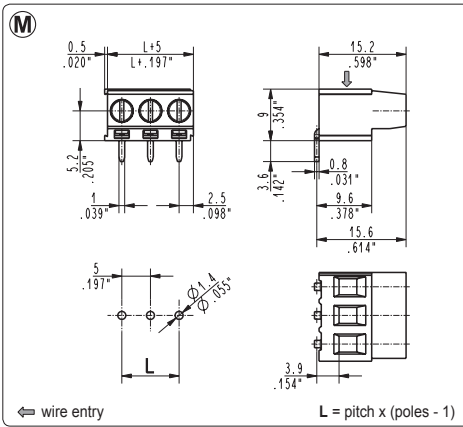

MSM_091 90°, modular

5 mm / .197" pitch

Poles	Code	Pcs/pack.	W [kg]*	Pcs/Ind.**	W [kg]*
02	MSM02091	900	2,70	2000	6,00
03	MSM03091	600	2,70	1750	7,88
04	MSM04091	400	2,40	1500	9,00
05	MSM05091	350	2,63	1000	7,50
06	MSM06091	300	2,70	750	6,75
07	MSM07091	250	2,63	750	7,88
08	MSM08091	200	2,40	750	9,00
09	MSM09091	175	2,36	500	6,75
10	MSM10091	175	2,63	500	7,50
11	MSM11091	150	2,48	500	8,25
12	MSM12091	150	2,70	500	9,00
13	MSM13091	75	1,46	500	9,75
14	MSM14091	75	1,58	250	5,25
15	MSM15091	75	1,69	250	5,63
16	MSM16091	75	1,80	250	6,00
17	MSM17091	75	1,91	250	6,38
18	MSM18091	75	2,03	250	6,75
19	MSM19091	50	1,43	250	7,13
20	MSM20091	50	1,50	250	7,50
21	MSM21091	50	1,58	250	7,88
22	MSM22091	50	1,65	250	8,25
23	MSM23091	50	1,73	250	8,63
24	MSM24091	50	1,80	250	9,00
25	MSM25091	50	1,88	250	9,38

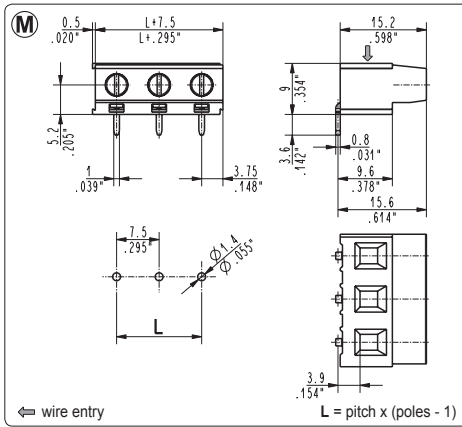

MSM_093 90°, modular

7.5 mm / .295" pitch

Poles	Code	Pcs/pack.	W [kg]*	Pcs/Ind.**	W [kg]*
02	MSM02093	300	1,05	1750	6,13
03	MSM03093	200	1,05	1500	7,88
04	MSM04093	150	1,05	1250	8,75

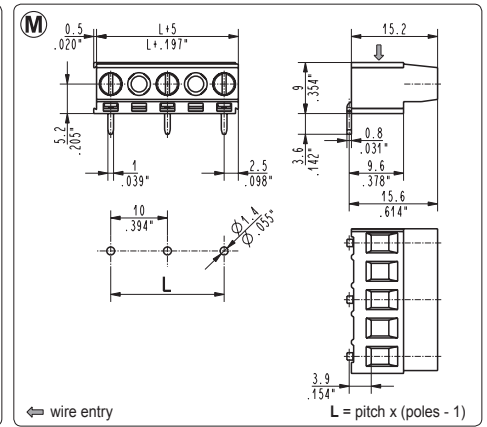

MSM_092 90°, modular

10 mm / .394" pitch

Poles	Code	Pcs/pack.	W [kg]*	Pcs/Ind.**	W [kg]*
01	MSM01092	450	0,80	2000	3,54
02	MSM02092	300	1,06	1750	6,20
03	MSM03092	175	0,93	1000	5,31
04	MSM04092	125	0,89	750	5,31
05	MSM05092	100	0,89	500	4,43
06	MSM06092	75	0,80	500	5,31
07	MSM07092	75	0,93	500	6,20
08	MSM08092	75	1,06	500	7,08
09	MSM09092	75	1,19	250	3,98
10	MSM10092	50	0,89	250	4,43
11	MSM11092	50	0,97	250	4,87
12	MSM12092	50	1,06	250	5,31
13	MSM13092	50	1,15	250	5,75

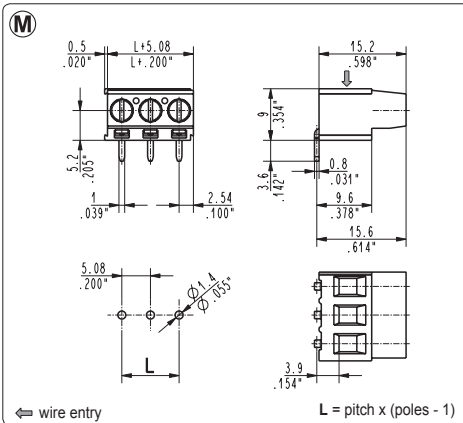

MSM_095 90°, modular

5.08 mm / .200" pitch

Poles	Code	Pcs/pack.	W [kg]*	Pcs/Ind.**	W [kg]*
02	MSM02095	900	2,70	2000	6,00
03	MSM03095	600	2,70	1750	7,88
04	MSM04095	400	2,40	1500	9,00
05	MSM05095	350	2,63	1000	7,50
06	MSM06095	300	2,70	750	6,75
07	MSM07095	250	2,63	750	7,88
08	MSM08095	200	2,40	750	9,00
09	MSM09095	175	2,36	500	6,75
10	MSM10095	175	2,63	500	7,50
11	MSM11095	150	2,48	500	8,25
12	MSM12095	150	2,70	500	9,00
13	MSM13095	75	1,46	500	9,75
14	MSM14095	75	1,58	250	5,25
15	MSM15095	75	1,69	250	5,63
16	MSM16095	75	1,80	250	6,00
17	MSM17095	75	1,91	250	6,38
18	MSM18095	75	2,03	250	6,75
19	MSM19095	50	1,43	250	7,13
20	MSM20095	50	1,50	250	7,50
21	MSM21095	50	1,58	250	7,88
22	MSM22095	50	1,65	250	8,25
23	MSM23095	50	1,73	250	8,63
24	MSM24095	50	1,80	250	9,00
25	MSM25095	50	1,88	250	9,38

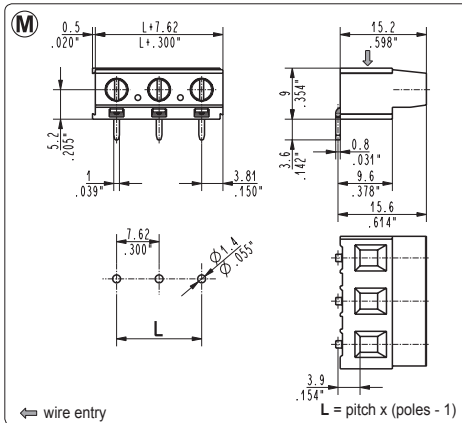

MSM_097 90°, modular

7.62 mm / .300" pitch

Poles	Code	Pcs/pack.	W [kg]*	Pcs/Ind.**	W [kg]*
02	MSM02097	300	1,05	1750	6,13
03	MSM03097	200	1,05	1500	7,88

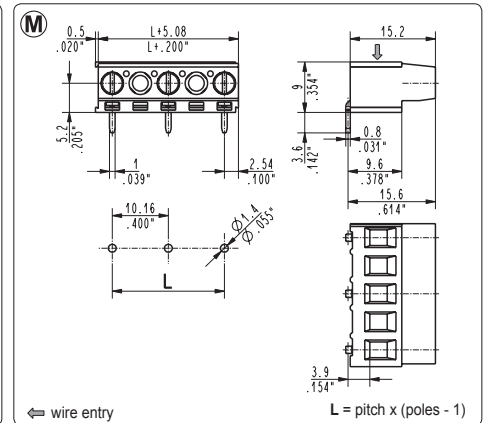

MSM_096 90°, modular

10.16 mm / .400" pitch

Poles	Code	Pcs/pack.	W [kg]*	Pcs/Ind.**	W [kg]*
01	MSM01096	450	0,80	2000	3,54
02	MSM02096	300	1,06	1750	6,20
03	MSM03096	175	0,93	1000	5,31
04	MSM04096	125	0,89	750	5,31
05	MSM05096	100	0,89	500	4,43
06	MSM06096	75	0,80	500	5,31
07	MSM07096	75	0,93	500	6,20
08	MSM08096	75	1,06	500	7,08
09	MSM09096	75	1,19	250	3,98
10	MSM10096	50	0,89	250	4,43
11	MSM11096	50	0,97	250	4,87
12	MSM12096	50	1,06	250	5,31
13	MSM13096	50	1,15	250	5,75

Modular version, combinable 2 + ∞ poles

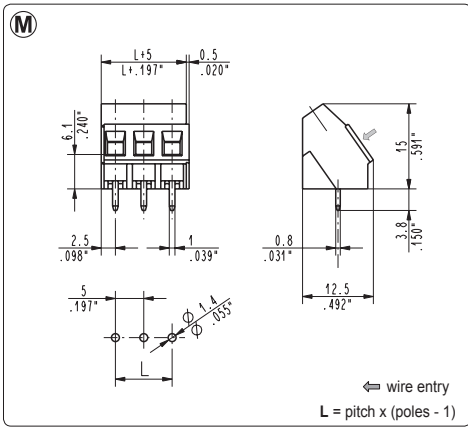

MSM_041 35°, modular

5 mm / .197" pitch					
Poles	Code	Pcs/pack.	W [kg]*	Pcs/Ind.**	W [kg]*
02	MSM02041	900	2,81	2500	7,80
03	MSM03041	600	2,81	1500	7,02
04	MSM04041	400	2,50	1500	9,36
05	MSM05041	350	2,73	1000	7,80
06	MSM06041	300	2,81	750	7,02
07	MSM07041	250	2,73	750	8,19
08	MSM08041	200	2,50	750	9,36
09	MSM09041	175	2,46	500	7,02
10	MSM10041	175	2,73	500	7,80
11	MSM11041	150	2,57	500	8,58
12	MSM12041	150	2,81	500	9,36

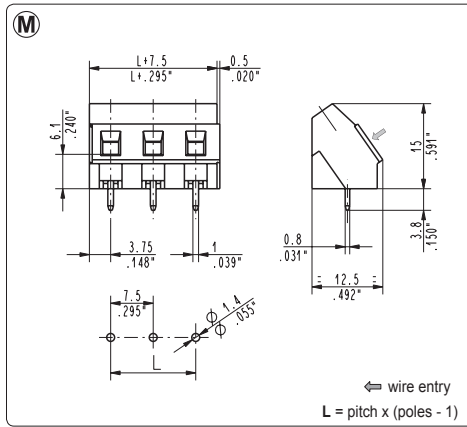

MSM_043 35° modular

7.5 mm / .295" pitch					
Poles	Code	Pcs/pack.	W [kg]*	Pcs/Ind.**	W [kg]*
02	MSM02043	300	1,05	1750	6,13
03	MSM03043	200	1,05	1500	7,88
04	MSM04043	150	1,05	1250	8,75
05	MSM05043	100	0,88	1000	8,75
06	MSM06043	75	0,79	750	7,88
07	MSM07043	75	0,92	750	9,19
08	MSM08043	75	1,05	750	10,50
09	MSM09043	75	1,18	500	7,88
10	MSM10043	75	1,31	500	8,75
11	MSM11043	50	0,96	250	4,81
12	MSM12043	50	1,05	250	5,25

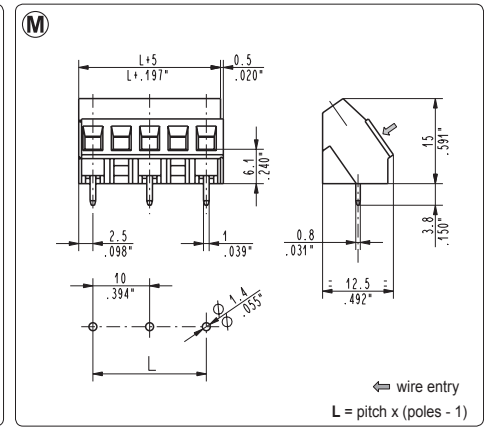

MSM_042 35° modular

10 mm / .394" pitch					
Poles	Code	Pcs/pack.	W [kg]*	Pcs/Ind.**	W [kg]*
01	MSM01042	450	0,80	2500	4,43
02	MSM02042	300	1,06	1500	5,31
03	MSM03042	175	0,93	1000	5,31
04	MSM04042	125	0,89	750	5,31
05	MSM05042	100	0,89	500	4,43
06	MSM06042	75	0,80	500	5,31

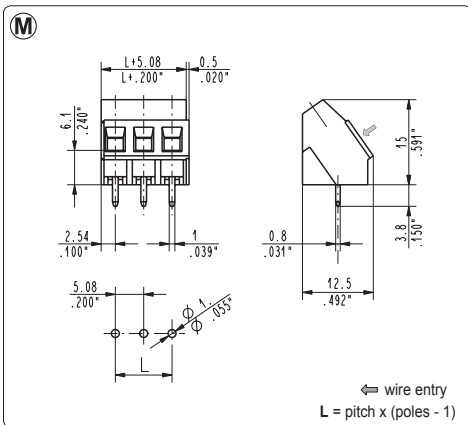

MSM_045 35°, modular

5.08 mm / .200" pitch					
Poles	Code	Pcs/pack.	W [kg]*	Pcs/Ind.**	W [kg]*
02	MSM02045	900	2,81	2500	7,80
03	MSM03045	600	2,81	1500	7,02
04	MSM04045	400	2,50	1500	9,36
05	MSM05045	350	2,73	1000	7,80
06	MSM06045	300	2,81	750	7,02
07	MSM07045	250	2,73	750	8,19
08	MSM08045	200	2,50	750	9,36
09	MSM09045	175	2,46	500	7,02
10	MSM10045	175	2,73	500	7,80
11	MSM11045	150	2,57	500	8,58
12	MSM12045	150	2,81	500	9,36
13	MSM13045	75	1,52	250	5,07
14	MSM14045	75	1,64	250	5,46
15	MSM15045	75	1,76	250	5,85
16	MSM16045	75	1,87	250	6,24
17	MSM17045	70	1,86	250	6,63
18	MSM18045	65	1,83	250	7,02
19	MSM19045	50	1,48	250	7,41
20	MSM20045	50	1,56	250	7,80
21	MSM21045	50	1,64	250	8,19
22	MSM22045	50	1,72	250	8,58
23	MSM23045	50	1,79	250	8,97
24	MSM24045	50	1,87	250	9,36
25	MSM25045	50	1,95	250	9,75

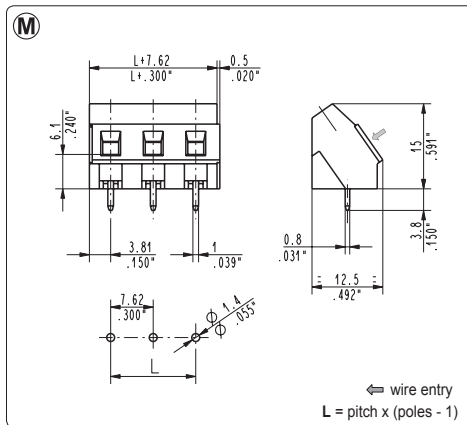

MSM_047 35°, modular

7.62 mm / .300" pitch					
Poles	Code	Pcs/pack.	W [kg]*	Pcs/Ind.**	W [kg]*
02	MSM02047	300	1,05	1750	6,13
03	MSM03047	200	1,05	1500	7,88
04	MSM04047	150	1,05	1250	8,75
05	MSM05047	100	0,88	1000	8,75
06	MSM06047	75	0,79	750	7,88
07	MSM07047	75	0,92	750	9,19
08	MSM08047	75	1,05	750	10,50
09	MSM09047	75	1,18	500	7,88
10	MSM10047	75	1,31	500	8,75
11	MSM11047	50	0,96	250	4,81
12	MSM12047	50	1,05	250	5,25

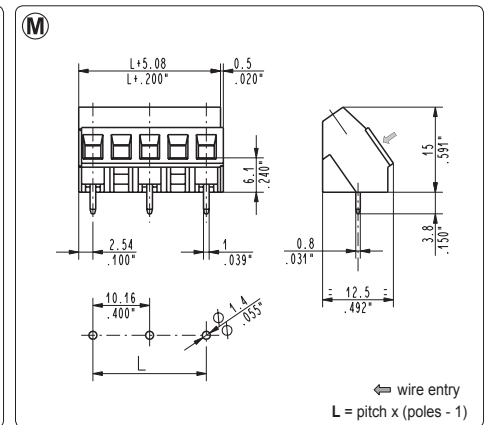

MSM_046 35°, modular

10.16 mm / .400" pitch					
Poles	Code	Pcs/pack.	W [kg]*	Pcs/Ind.**	W [kg]*
01	MSM01046	450	0,80	2500	4,43
02	MSM02046	300	1,06	1500	5,31
03	MSM03046	175	0,93	1000	5,31
04	MSM04046	125	0,89	750	5,31
05	MSM05046	100	0,89	500	4,43
06	MSM06046	75	0,80	500	5,31
07	MSM07046	75	0,93	500	6,20
08	MSM08046	75	1,06	250	3,54
09	MSM09046	75	1,19	250	3,98
10	MSM10046	50	0,89	250	4,43
11	MSM11046	50	0,97	250	4,87
12	MSM12046	50	1,06	250	5,31
13	MSM13046	50	1,15	250	5,75

*W [kg]: approximate weight per box in kg

**industrial packaging: add "-00000E" at standard code

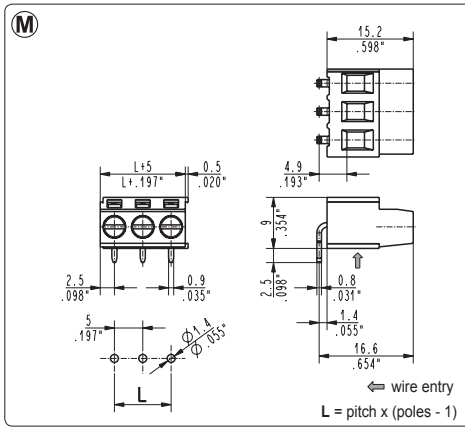

MSM_051 270° bottom entry, modular

5 mm / .197" pitch

Poles	Code	Pcs/pack.	W [kg]*	Pcs/Ind.**	W [kg]*
02	MSM02051	900	2,81	2000	6,24
03	MSM03051	600	2,81	1750	8,19
04	MSM04051	400	2,50	1500	9,36
05	MSM05051	350	2,73	1000	7,80
06	MSM06051	300	2,81	750	7,02
07	MSM07051	250	2,73	750	8,19
08	MSM08051	200	2,50	750	9,36
09	MSM09051	175	2,46	500	7,02
10	MSM10051	175	2,73	500	7,80
11	MSM11051	150	2,57	500	8,58
12	MSM12051	150	2,81	500	9,36
13	MSM13051	75	1,52	500	10,14
14	MSM14051	75	1,64	250	5,46
15	MSM15051	75	1,76	250	5,85
16	MSM16051	75	1,87	250	6,24
17	MSM17051	75	1,99	250	6,63
18	MSM18051	75	2,11	250	7,02
19	MSM19051	50	1,48	250	7,41
20	MSM20051	50	1,56	250	7,80
21	MSM21051	50	1,64	250	8,19
22	MSM22051	50	1,72	250	8,58
23	MSM23051	50	1,79	250	8,97
24	MSM24051	50	1,87	250	9,36
25	MSM25051	50	1,95	250	9,75

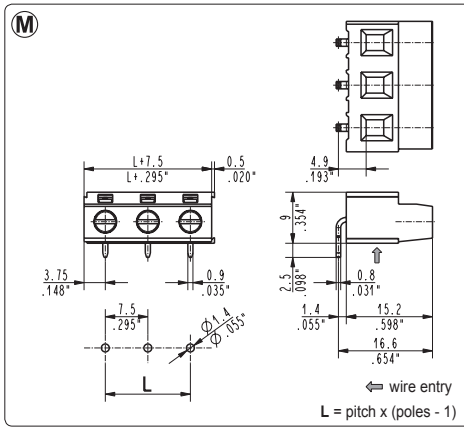

MSM_053 270° bottom entry, modular

7.5 mm / .295" pitch

Poles	Code	Pcs/pack.	W [kg]*	Pcs/Ind.**	W [kg]*
02	MSM02053	300	1,05	1750	6,13
03	MSM03053	200	1,05	1500	7,88
04	MSM04053	150	1,05	1250	8,75

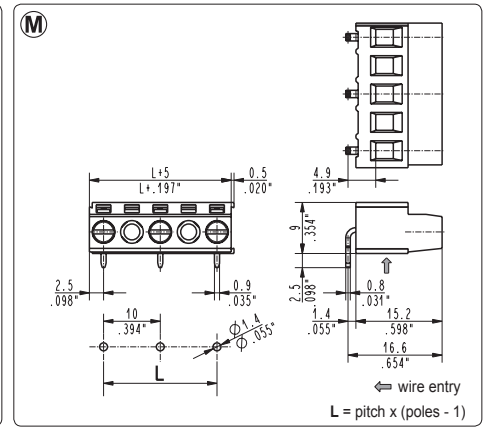

MSM_052 270° bottom entry, modular

10 mm / .394" pitch

Poles	Code	Pcs/pack.	W [kg]*	Pcs/Ind.**	W [kg]*
01	MSM01052	450	0,80	2000	3,54
02	MSM02052	300	1,06	1750	6,20
03	MSM03052	175	0,93	1000	5,31
04	MSM04052	125	0,89	750	5,31
05	MSM05052	100	0,89	500	4,43
06	MSM06052	75	0,80	500	5,31
07	MSM07052	75	0,93	500	6,20
08	MSM08052	75	1,06	500	7,08
09	MSM09052	75	1,19	250	3,98
10	MSM10052	50	0,89	250	4,43
11	MSM11052	50	0,97	250	4,87
12	MSM12052	50	1,06	250	5,31
13	MSM13052	50	1,15	250	5,75

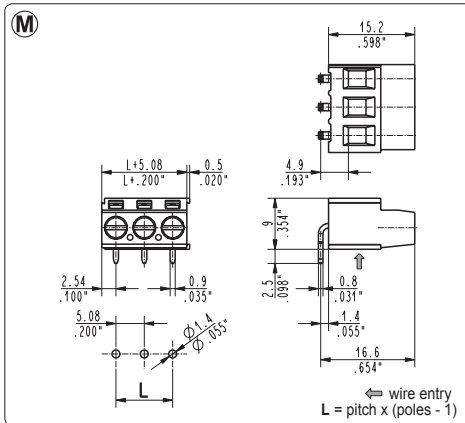

MSM_055 270° bottom entry, modular

5.08 mm / .200" pitch

Poles	Code	Pcs/pack.	W [kg]*	Pcs/Ind.**	W [kg]*
02	MSM02055	900	2,81	2000	6,24
03	MSM03055	600	2,81	1750	8,19
04	MSM04055	400	2,50	1500	9,36
05	MSM05055	350	2,73	1000	7,80
06	MSM06055	300	2,81	750	7,02
07	MSM07055	250	2,73	750	8,19
08	MSM08055	200	2,50	750	9,36
09	MSM09055	175	2,46	500	7,02
10	MSM10055	175	2,73	500	7,80
11	MSM11055	150	2,57	500	8,58
12	MSM12055	150	2,81	500	9,36
13	MSM13055	75	1,52	500	10,14
14	MSM14055	75	1,64	250	5,46
15	MSM15055	75	1,76	250	5,85
16	MSM16055	75	1,87	250	6,24
17	MSM17055	75	1,99	250	6,63
18	MSM18055	75	2,11	250	7,02
19	MSM19055	50	1,48	250	7,41
20	MSM20055	50	1,56	250	7,80
21	MSM21055	50	1,64	250	8,19
22	MSM22055	50	1,72	250	8,58
23	MSM23055	50	1,79	250	8,97
24	MSM24055	50	1,87	250	9,36
25	MSM25055	50	1,95	250	9,75

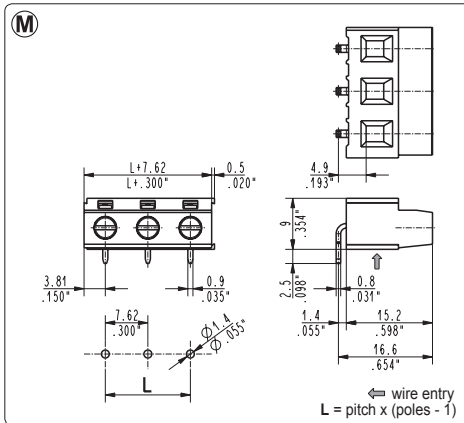

MSM_057 270° bottom entry, modular

7.62 mm / .300" pitch

Poles	Code	Pcs/pack.	W [kg]*	Pcs/Ind.**	W [kg]*
02	MSM02057	300	1,05	1750	6,13
03	MSM03057	200	1,05	1500	7,88

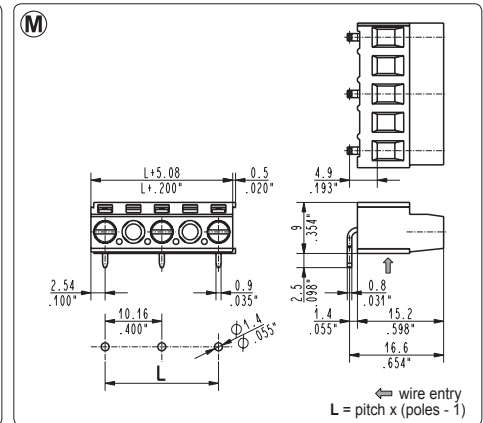

MSM_056 270° bottom entry, modular

10.16 mm / .400" pitch

Poles	Code	Pcs/pack.	W [kg]*	Pcs/Ind.**	W [kg]*
01	MSM01056	450	0,80	2000	3,54
02	MSM02056	300	1,06	1750	6,20
03	MSM03056	175	0,93	1000	5,31
04	MSM04056	125	0,89	750	5,31
05	MSM05056	100	0,89	500	4,43
06	MSM06056	75	0,80	500	5,31
07	MSM07056	75	0,93	500	6,20
08	MSM08056	75	1,06	500	7,08
09	MSM09056	75	1,19	250	3,98
10	MSM10056	50	0,89	250	4,43
11	MSM11056	50	0,97	250	4,87
12	MSM12056	50	1,06	250	5,31
13	MSM13056	50	1,15	250	5,75

Modular version, combinable 2 + ∞ poles

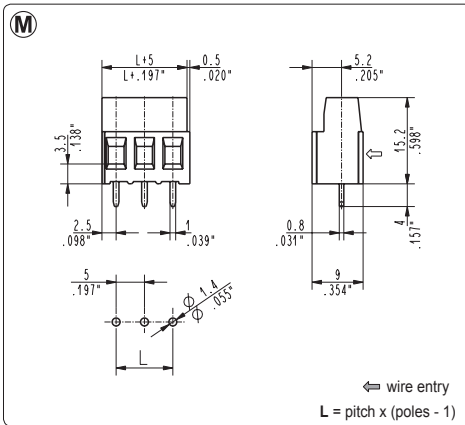

MSM_001-000T straight, modular

5 mm / .197" pitch

Poles	Code	Pcs/pack.	W [kg]*	Pcs/Ind.**	W [kg]*
02	MSM02001-000T	900	2,81	2000	6,24
03	MSM03001-000T	600	2,81	1750	8,19
04	MSM04001-000T	400	2,50	1500	9,36
05	MSM05001-000T	350	2,73	1000	7,80
06	MSM06001-000T	300	2,81	750	7,02
07	MSM07001-000T	250	2,73	750	8,19
08	MSM08001-000T	200	2,50	750	9,36
09	MSM09001-000T	175	2,46	500	7,02
10	MSM10001-000T	175	2,73	500	7,80
11	MSM11001-000T	150	2,57	500	8,58
12	MSM12001-000T	150	2,81	500	9,36
13	MSM13001-000T	75	1,52	500	10,14
14	MSM14001-000T	75	1,64	250	5,46
15	MSM15001-000T	75	1,76	250	5,85
16	MSM16001-000T	75	1,87	250	6,24
17	MSM17001-000T	75	1,99	250	6,63
18	MSM18001-000T	75	2,11	250	7,02
19	MSM19001-000T	50	1,48	250	7,41
20	MSM20001-000T	50	1,56	250	7,80
21	MSM21001-000T	50	1,64	250	8,19
22	MSM22001-000T	50	1,72	250	8,58
23	MSM23001-000T	50	1,79	250	8,97
24	MSM24001-000T	50	1,87	250	9,36
25	MSM25001-000T	50	1,95	250	9,75

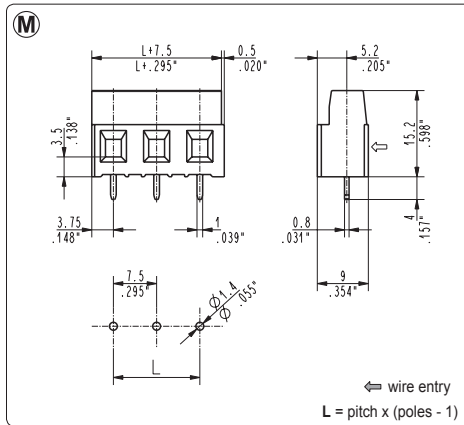

MSM_003-000T straight, modular

7.5 mm / .295" pitch

Poles	Code	Pcs/pack.	W [kg]*	Pcs/Ind.**	W [kg]*
02	MSM02003-000T	300	1,05	1750	6,13
03	MSM03003-000T	200	1,05	1500	7,88
04	MSM04003-000T	150	1,05	1250	8,75

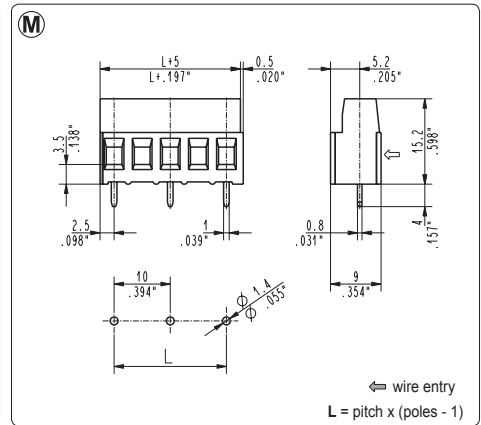

MSM_002-000T straight, modular

10 mm / .394" pitch

Poles	Code	Pcs/pack.	W [kg]*	Pcs/Ind.**	W [kg]*
01	MSM01002-000T	450	0,80	2000	3,54
02	MSM02002-000T	300	1,06	1750	6,20
03	MSM03002-000T	175	0,93	1000	5,31
04	MSM04002-000T	125	0,89	750	5,31
05	MSM05002-000T	100	0,89	500	4,43
06	MSM06002-000T	75	0,80	500	5,31
07	MSM07002-000T	75	0,93	500	6,20
08	MSM08002-000T	75	1,06	500	7,08
09	MSM09002-000T	75	1,19	250	3,98
10	MSM10002-000T	50	0,89	250	4,43
11	MSM11002-000T	50	0,97	250	4,87
12	MSM12002-000T	50	1,06	250	5,31
13	MSM13002-000T	50	1,15	250	5,75

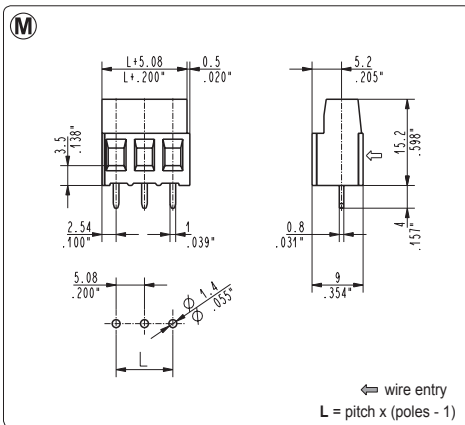

MSM_005-000T straight, modular

5.08 mm / .200" pitch

Poles	Code	Pcs/pack.	W [kg]*	Pcs/Ind.**	W [kg]*
02	MSM02005-000T	900	2,81	2000	6,24
03	MSM03005-000T	600	2,81	1750	8,19
04	MSM04005-000T	400	2,50	1500	9,36
05	MSM05005-000T	350	2,73	1000	7,80
06	MSM06005-000T	300	2,81	750	7,02
07	MSM07005-000T	250	2,73	750	8,19
08	MSM08005-000T	200	2,50	750	9,36
09	MSM09005-000T	175	2,46	500	7,02
10	MSM10005-000T	175	2,73	500	7,80
11	MSM11005-000T	150	2,57	500	8,58
12	MSM12005-000T	150	2,81	500	9,36
13	MSM13005-000T	75	1,52	500	10,14
14	MSM14005-000T	75	1,64	250	5,46
15	MSM15005-000T	75	1,76	250	5,85
16	MSM16005-000T	75	1,87	250	6,24
17	MSM17005-000T	75	1,99	250	6,63
18	MSM18005-000T	75	2,11	250	7,02
19	MSM19005-000T	50	1,48	250	7,41
20	MSM20005-000T	50	1,56	250	7,80
21	MSM21005-000T	50	1,64	250	8,19
22	MSM22005-000T	50	1,72	250	8,58
23	MSM23005-000T	50	1,79	250	8,97
24	MSM24005-000T	50	1,87	250	9,36
25	MSM25005-000T	50	1,95	250	9,75

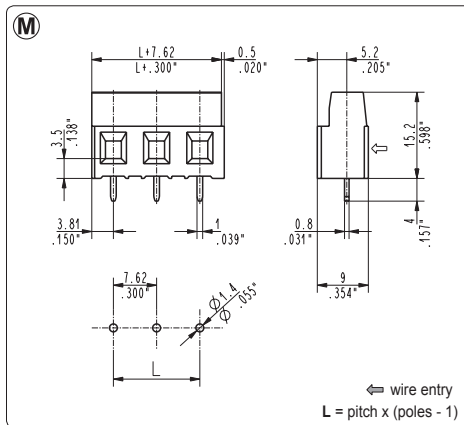

MSM_007-000T straight, modular

7.62 mm / .300" pitch

Poles	Code	Pcs/pack.	W [kg]*	Pcs/Ind.**	W [kg]*
02	MSM02007-000T	300	1,05	1750	6,13
03	MSM03007-000T	200	1,05	1500	7,88

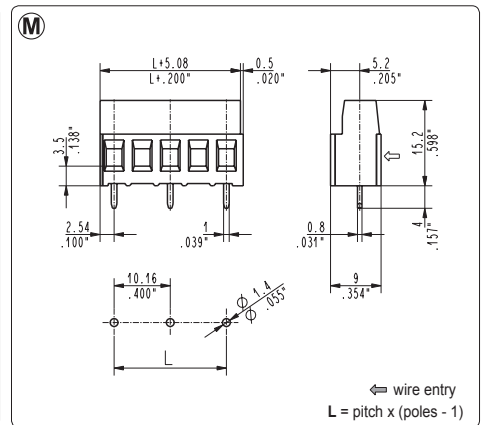

MSM_006-000T straight, modular

10.16 mm / .400" pitch

Poles	Code	Pcs/pack.	W [kg]*	Pcs/Ind.**	W [kg]*
01	MSM01006-000T	450	0,80	2000	3,54
02	MSM02006-000T	300	1,06	1750	6,20
03	MSM03006-000T	175	0,93	1000	5,31
04	MSM04006-000T	125	0,89	750	5,31
05	MSM05006-000T	100	0,89	500	4,43
06	MSM06006-000T	75	0,80	500	5,31
07	MSM07006-000T	75	0,93	500	6,20
08	MSM08006-000T	75	1,06	500	7,08
09	MSM09006-000T	75	1,19	250	3,98
10	MSM10006-000T	50	0,89	250	4,43
11	MSM11006-000T	50	0,97	250	4,87
12	MSM12006-000T	50	1,06	250	5,31
13	MSM13006-000T	50	1,15	250	5,75

*W [kg]: approximate weight per box in kg

**industrial packaging: add "-00000E" at standard code